

TRAFFIC ACCIDENT FACTS and STATISTICS

1985

Pennsylvania Department of Transportation

INTRODUCTION

The 1985 TRAFFIC ACCIDENT FACTS AND STATISTICS is a report published by the Center For Highway Safety of the Pennsylvania Department of Transportation.

This publication is a statistical review of motor vehicle traffic accidents in the Commonwealth of Pennsylvania for the calendar year 1985. The figures are compiled from the traffic accident reports that are submitted to the Pennsylvania Department of Transportation by state, county, city and other law enforcement agencies.

Specific questions regarding data presented in this report should be addressed to:

Pennsylvania Department of Transportation
Center For Highway Safety
215 Transportation and Safety Building
Harrisburg, PA 17120
(717) 787-7350

TABLE OF CONTENTS

I.	Highlights and Trends	5
II.	Geographic Information	17
III.	Fatality and Injury Characteristics	23
IV.	Seat Belt Statistics	29
V.	Driver and Vehicle Characteristics	37
VI.	Alcohol Involvement in Accidents	47
VII.	Pedestrian Related Accident Statistics	69
VIII.	Special Information by Vehicle Type	81
IX.	Definitions	109

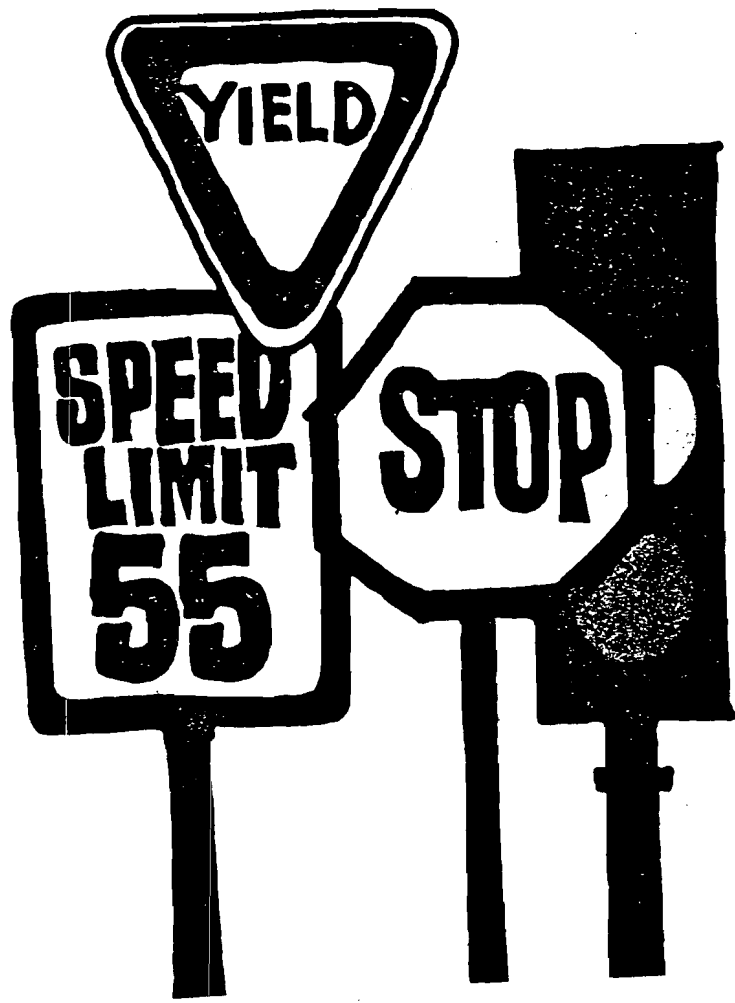

HIGHLIGHTS AND TRENDS

1985

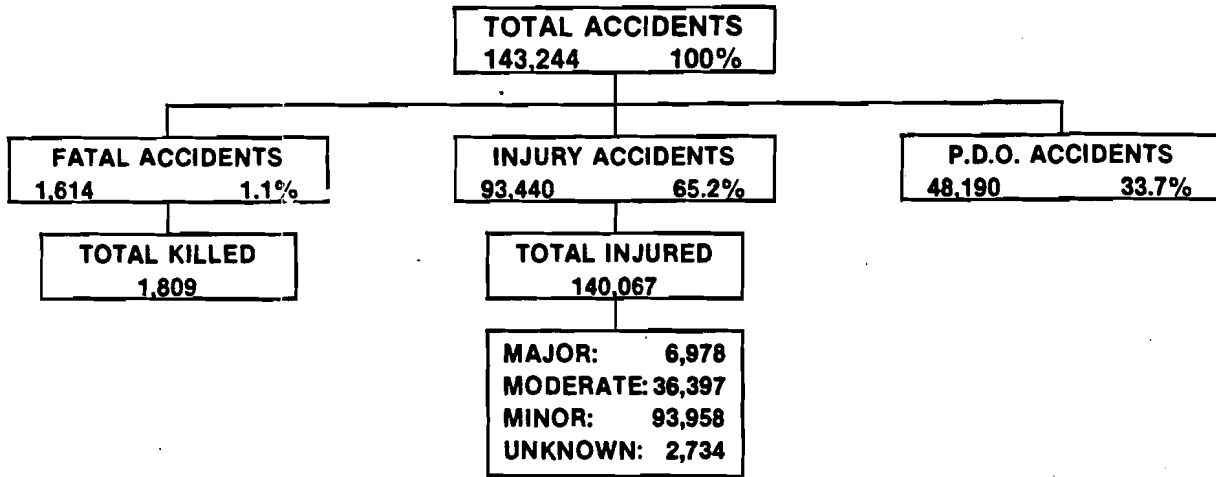

1985 OPERATOR-VEHICLE-ROAD DATA

7,555,006 LICENSED OPERATORS

7,860,497 REGISTERED MOTOR VEHICLES

114,865.309 MAINTAINED MILES OF ROAD

STATE: 43,333.359

LOCAL: 66,668.030

TURNPIKE: 469.000

OTHER: 4,394.920

75.6 BILLION VEHICLE MILES DRIVEN

143,244 ACCIDENTS

PEOPLE KILLED: 1,809

PEOPLE INJURED: 140,067

ECONOMIC LOSS: \$1,908,272,046

PA ACCIDENT FACTS

	1984	1985	Percent Change
REPORTED ACCIDENTS	139,914	143,244	+ 2.4
TOTAL KILLED	1,752	1,809	+ 3.3
TOTAL INJURED	134,714	140,067	+ 4.0
MAJOR	6,642	6,978	+ 5.1
MODERATE	35,533	36,397	+ 2.4
MINOR	89,994	93,958	+ 4.4
UNKNOWN	2,545	2,734	+ 4.4
PEDESTRIANS KILLED	316	265	- 16.1
PEDESTRIANS INJURED	6,784	6,869	+ 1.3
MOTORCYCLISTS KILLED	172	177	+ 2.9
MOTORCYCLISTS INJURED	5,617	6,005	+ 6.9
PEDALCYCLISTS KILLED	29	30	+ 3.4
PEDALCYCLISTS INJURED	3,249	3,484	+ 7.2
BILLIONS OF VEHICLE MILES TRAVELED	74.1	75.6	+ 2.0
DEATHS PER 100 MILLION VEHICLE MILES	2.36	2.39	+ 1.3
INJURIES PER 100 MILLION VEHICLE MILES	181.80	185.17	+ 1.9

In 1985 --

5 PERSONS WERE KILLED EVERY DAY (ONE EVERY 4.8 HOURS).
 383.7 PERSONS WERE INJURED EVERY DAY (ONE EVERY 3.8 MINUTES).

ONE PA LICENSED DRIVER OUT OF 36.2 WAS INVOLVED IN AN ACCIDENT.
 ONE PA REGISTERED VEHICLE OUT OF 35.4 WAS INVOLVED IN AN ACCIDENT.

69.3% OF DRIVERS IN ALL ACCIDENTS WERE MALE.
 81.6% OF DRIVERS IN FATAL ACCIDENTS WERE MALE.

54.9% OF ALL ACCIDENTS HAPPENED IN DAYLIGHT CONDITIONS.
 53.2% OF FATAL ACCIDENTS HAPPENED IN DARK CONDITIONS.

41.8% OF FATAL ACCIDENTS HAPPENED ON WEEKENDS FROM 6pm FRIDAY TO MIDNIGHT SUNDAY.
 MOST DANGEROUS DAY: FRIDAY WITH 18.6% OF ALL ACCIDENTS.

74.6% OF ALL ACCIDENTS OCCURRED UNDER NO ADVERSE WEATHER CONDITIONS.
 65.7% OF ALL ACCIDENTS OCCURRED ON A DRY SURFACE.

14.1% OF ALL ACCIDENTS INVOLVED ALCOHOL.
 41.7% OF FATAL ACCIDENTS INVOLVED ALCOHOL.

HISTORICAL TRENDS — PA HIGHWAY ACCIDENT STATISTICS

YEAR	TOTAL ACCIDENTS	TOTAL KILLED	TOTAL INJURED	REGISTERED VEHICLES	(Billion) Motor Vehicle MILEAGE	(Per 100 Million Vehicle Miles) PA FATALITY RATE	US FATALITY RATE
1928	27,082	2,080	20,223	1,713,920	.	.	.
1929	43,776	2,331	35,648	1,829,685	.	.	.
1930	47,917	2,566	99,793	1,843,539	.	.	.
1931	46,588	2,503	40,800	1,826,736	.	.	.
1932	41,004	2,131	41,836	1,750,664	.	.	.
1933	45,374	2,279	47,908	1,716,104	.	.	.
1934	52,157	2,535	51,847	1,791,870	.	.	.
1935	50,436	2,361	48,398	1,851,945	11.1	21.3	15.9
1936	55,727	2,426	50,854	1,989,507	12.6	19.2	15.1
1937	73,534	2,564	61,445	2,124,525	17.6	14.6	14.7
1938	63,153	1,892	50,598	2,101,299	16.3	11.6	12.0
1939	69,950	1,871	55,821	2,237,960	18.5	10.1	11.3
1940	78,625	2,074	58,664	2,307,723	19.8	10.5	11.4
1941	83,507	2,298	60,499	2,432,319	21.3	10.8	12.0
1942	59,280	1,745	41,122	2,267,301	17.6	9.9	10.6
1943	37,419	1,374	27,312	2,084,332	13.9	9.9	11.5
1944	42,699	1,328	29,928	2,010,163	14.4	9.2	11.5
1945	53,304	1,453	35,686	2,145,452	16.0	9.1	11.3
1946	70,065	1,794	45,889	2,387,542	22.1	8.1	9.8
1947	89,190	1,678	49,938	2,604,741	22.4	7.5	8.8
1948	103,478	1,671	52,709	2,804,056	23.9	7.0	8.1
1949	102,098	1,624	54,290	2,993,903	25.8	6.3	7.5
1950	113,748	1,624	62,103	3,262,243	27.1	6.0	7.6
1951	123,088	1,642	65,643	3,413,836	28.8	5.7	7.1
1952	126,820	1,680	67,134	3,510,064	30.5	5.5	7.1
1953	129,791	1,643	70,531	3,684,468	31.6	5.2	6.7
1954	130,326	1,538	68,571	3,803,917	32.0	4.8	6.1
1955	147,837	1,727	76,836	4,045,995	34.5	5.0	6.1
1956	160,371	1,790	84,813	4,175,217	36.5	4.9	6.1
1957	161,080	1,698	84,755	4,250,576	37.7	4.5	5.8
1958	156,825	1,654	86,733	4,355,813	38.5	4.3	5.4
1959	157,191	1,685	90,807	4,507,262	39.2	4.3	5.4
1960	159,051	1,609	82,792	4,707,055	40.2	4.0	5.3
1961	156,559	1,486	73,997	4,842,400	40.2	3.7	5.2
1962	161,557	1,625	81,936	4,849,400	41.7	3.9	5.3
1963	174,527	1,830	86,892	5,117,229	44.6	4.1	5.5
1964	183,910	1,889	93,564	5,351,350	46.1	4.1	5.7
1965	213,769	2,079	111,123	5,436,349	48.3	4.3	5.6
1966	254,450	2,180	116,527	5,497,000	51.1	4.27	5.70
1967	243,798	2,331	126,417	5,673,000	53.4	4.37	5.50
1968	279,663	2,410	138,389	5,791,000	56.1	4.29	5.40
1969	292,192	2,401	141,728	5,879,000	58.6	4.10	5.21
1970	311,981	2,255	136,518	5,947,000	56.7	3.98	4.88
1971	301,374	2,299	127,318	6,079,000	60.9	3.78	4.57
1972	277,556	2,352	135,938	6,244,000	67.0	3.51	4.43
1973	307,648	2,444	145,452	7,007,192	66.5	3.67	4.24
1974	277,271	2,155	132,689	8,354,063	63.9	3.37	3.59
1975	288,245	2,082	134,969	8,654,333	63.7	3.27	3.45
1976	308,774	2,025	135,308	9,124,915	69.4	2.92	3.33
1977	243,702	2,071	148,725	8,833,745	72.3	2.87	3.35
1978	158,361	2,137	146,403	7,254,893	72.7	2.94	3.39
1979	156,622	2,204	144,300	7,451,021	70.3	3.14	3.50
1980	142,489	2,114	133,716	7,307,974	71.3	2.96	3.50
1981	138,764	2,049	131,301	7,252,836	71.5	2.87	3.30
1982	131,579	1,848	126,026	7,417,311	71.3	2.59	2.88
1983	131,081	1,752	126,707	7,562,726	72.3	2.42	2.69
1984	139,914	1,752	134,714	7,724,686	74.1	2.36	2.68
1985	143,244	1,809	140,067	7,860,497	75.6	2.39	2.48

**ECONOMIC LOSS DUE TO
REPORTABLE TRAFFIC ACCIDENTS
1985**

SEVERITY	NUMBER	AVERAGE* COSTS	ESTIMATED COSTS
FATALITIES	1,809	\$328,377.00	\$594,033,993.00
INJURIES			
MAJOR	6,978	98,125.00	684,716,250.00
MODERATE	36,397	7,735.00	281,530,795.00
MINOR	93,958	2,781.00	261,297,198.00
PROPERTY DAMAGE ONLY ACCIDENTS	48,190	1,799.00	86,693,810.00
TOTAL			\$1,908,272,046.00

THE ECONOMIC LOSS TO EVERY MAN, WOMAN AND CHILD IN PA IN 1985 WAS \$154.00.

1985 Fatality Rates: PA vs Neighboring States
Rate: Fatalities per 100 Million Vehicle Miles

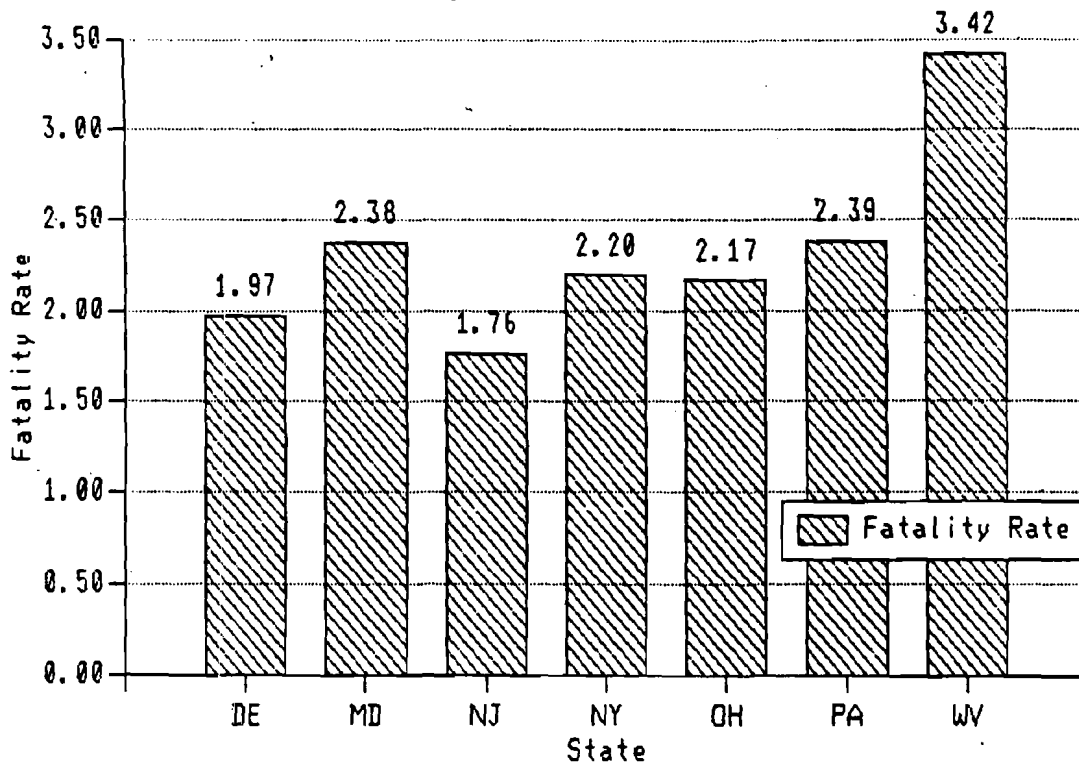

Fatality Rates: PA vs US
Rate: Fatalities per 100 Million Vehicle Miles

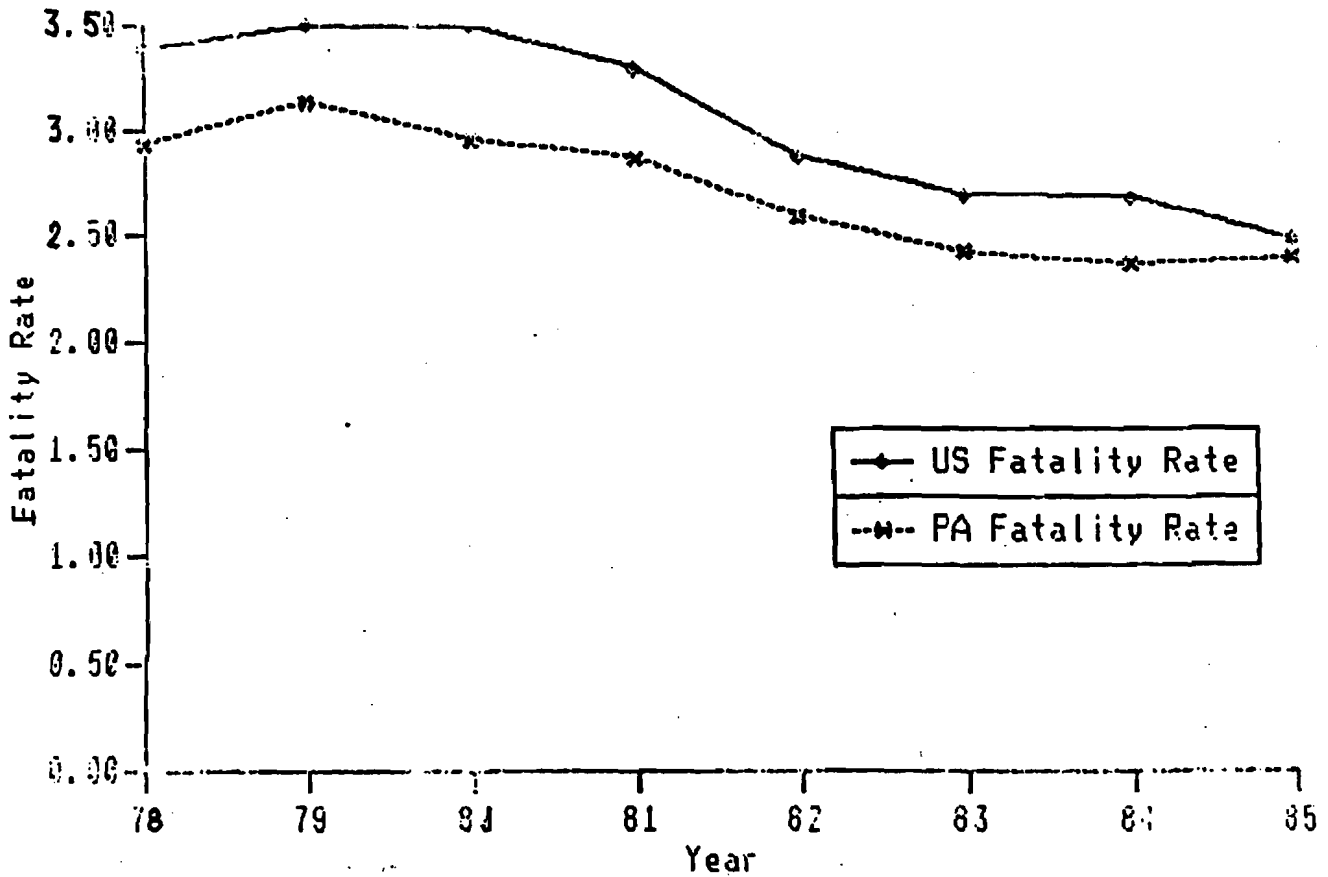

Pennsylvania Highway Fatalities 1978-1985

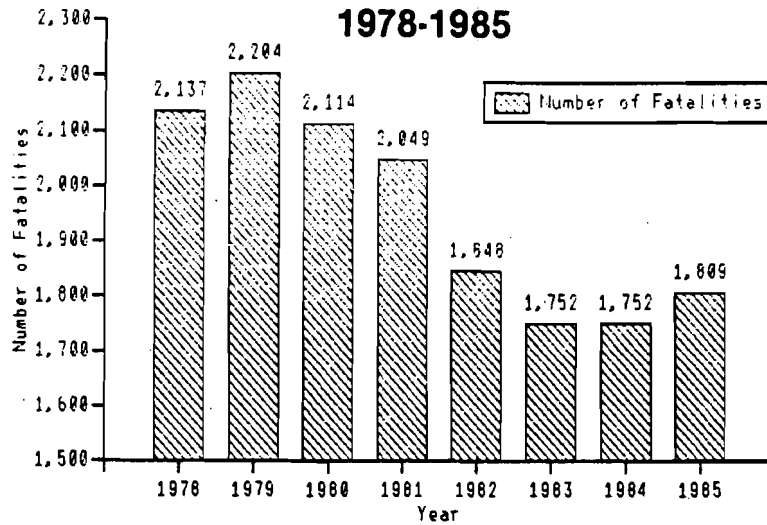

1985 Injury Rates: PA vs Neighboring States Rate: Injury per 100 Million Vehicle Miles

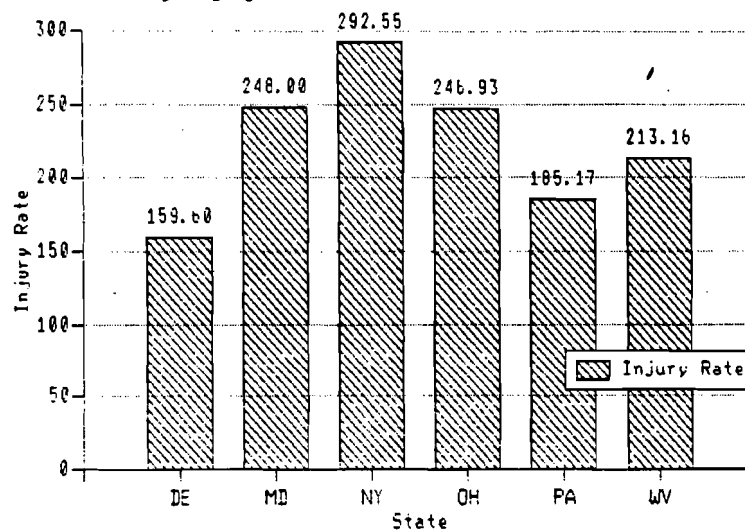

PA Highway Accidents 1976-1985

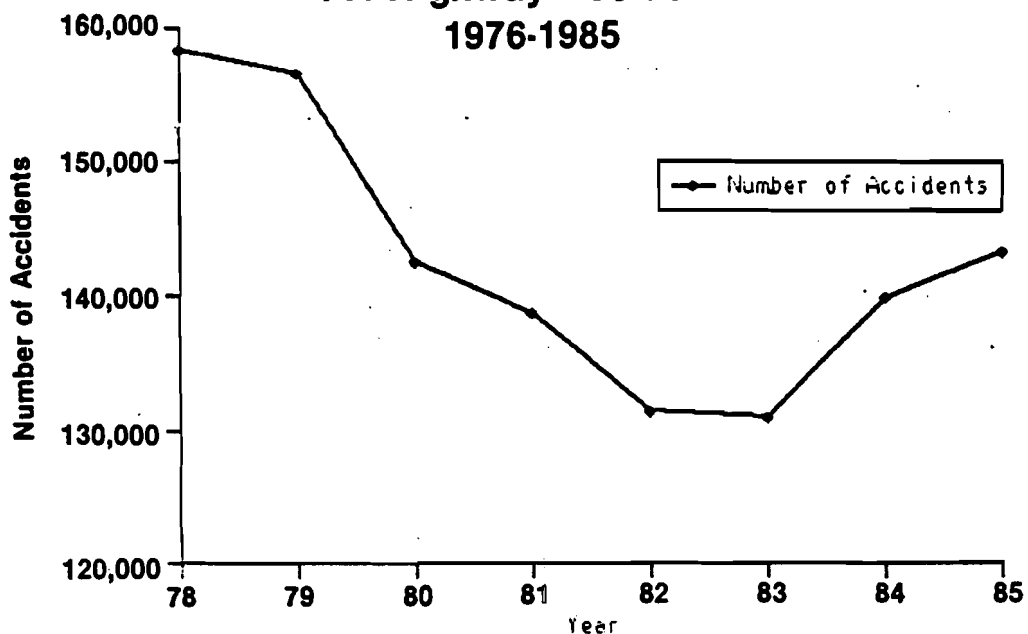

1985 HOLIDAY ACCIDENTS

HOLIDAY	BEGIN (6:00 pm)	END (12 midn)	FATAL ACC'S	TOTAL KILLED	INJURY ACC'S	TOTAL INJURED	PDO ACC'S	TOTAL ACC'S
NEW YEAR'S HOLIDAY	Dec. 28th	January 1st	12	12	925	1,412	499	1,436
MEMORIAL DAY								
PRE	May 17th	May 20th	14	20	940	1,438	447	1,401
HOLIDAY	May 24th	May 27th	21	24	809	1,246	352	1,182
POST	May 31st	June 3rd	16	16	876	1,330	409	1,301
4th OF JULY								
PRE	June 27th	June 30th	21	24	1,333	2,096	674	2,028
HOLIDAY	July 3rd	July 7th	18	20	1,171	1,870	479	1,668
POST	July 10th	July 14th	24	25	1,098	1,738	479	1,601
LABOR DAY								
PRE	August 23rd	August 26th	19	21	1,036	1,668	463	1,518
HOLIDAY	August 30th	Sept. 2nd	27	31	798	1,265	361	1,186
POST	Sept. 6th	Sept. 9th	17	19	837	1,267	409	1,263
THANKSGIVING								
PRE	Nov. 20th	Nov. 24th	13	21	1,213	1,815	652	1,878
HOLIDAY	Nov. 27th	Dec. 1st	28	32	1,243	2,013	702	1,973
POST	Dec. 3rd	Dec. 7th	19	21	1,200	1,814	840	2,059
CHRISTMAS								
PRE	Dec. 16th	Dec. 18th	13	14	627	914	398	1,038
HOLIDAY	Dec. 23rd	Dec. 25th	9	9	700	1,039	427	1,136
TOTAL	--	--	271	309	14,806	22,925	7,591	22,668
TOTAL HOLIDAY	--	--	115	128	5,646	8,845	2,820	8,581

1985 ALCOHOL RELATED HOLIDAY ACCIDENTS

HOLIDAY	BEGIN (6:00 pm)	END (12 midn)	FATAL ACC'S	TOTAL KILLED	INJURY ACC'S	TOTAL INJURED	PDO ACC'S	TOTAL ACC'S
NEW YEAR'S HOLIDAY	Dec. 28th	January 1st	6	6	187	272	105	298
MEMORIAL DAY								
PRE	May 17th	May 20th	6	8	194	289	84	284
HOLIDAY	May 24th	May 27th	15	18	167	253	85	267
POST	May 31st	June 3rd	8	8	150	236	60	218
4th OF JULY								
PRE	June 27th	June 30th	8	9	216	345	109	333
HOLIDAY	July 3rd	July 7th	5	5	227	348	96	328
POST	July 10th	July 14th	14	15	171	290	76	261
LABOR DAY								
PRE	August 23rd	August 26th	4	5	182	279	80	266
HOLIDAY	August 30th	Sept. 2nd	10	10	96	155	42	148
POST	Sept. 6th	Sept. 9th	9	10	146	217	73	228
THANKSGIVING								
PRE	Nov. 20th	Nov. 24th	8	16	204	302	106	318
HOLIDAY	Nov. 27th	Dec. 1st	15	17	244	403	108	367
POST	Dec. 3rd	Dec. 7th	8	9	173	273	82	263
CHRISTMAS								
PRE	Dec. 16th	Dec. 18th	4	4	60	84	26	90
HOLIDAY	Dec. 23rd	Dec. 25th	3	3	159	219	80	242
TOTAL	—	—	123	143	2,576	3,965	1,212	3,911
TOTAL HOLIDAY	—	—	54	59	1,080	1,650	516	1,650

Holiday Fatal Accidents 1983-1985

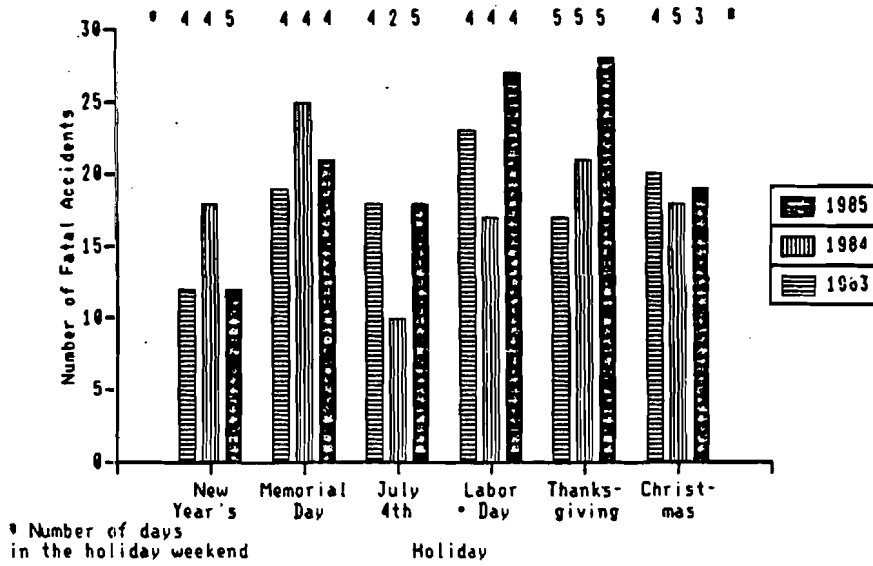

Holiday Fatalities 1983-1985

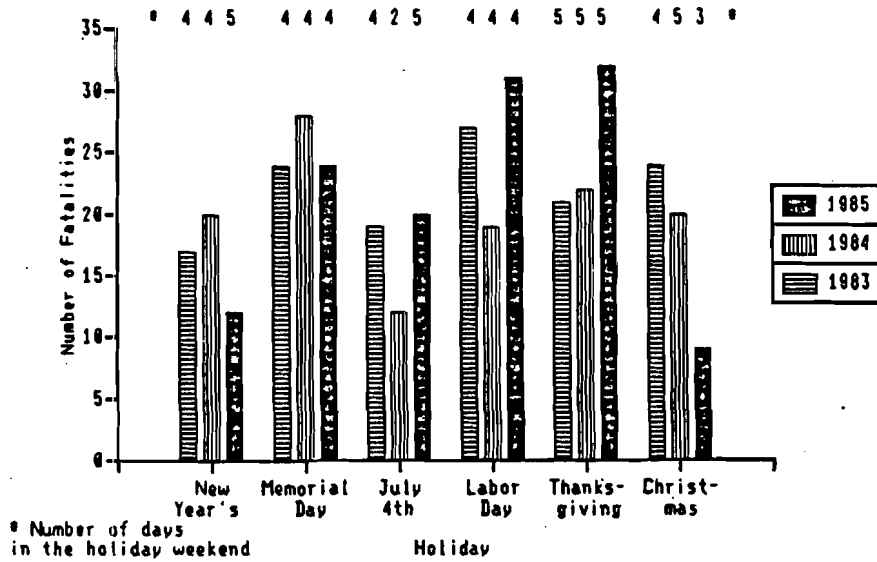

Holiday Alcohol Related Fatal Accidents 1983-1985

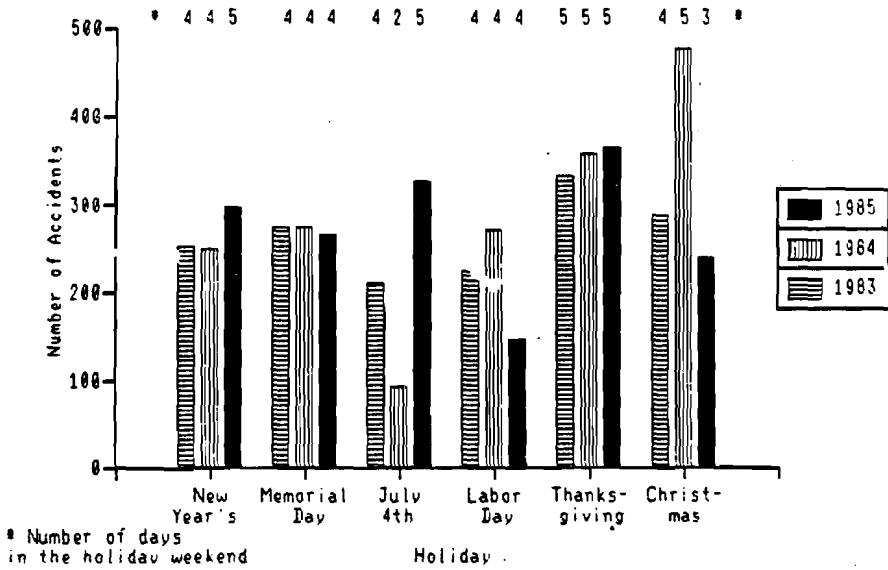

Holiday Alcohol Related Accidents 1983-1985

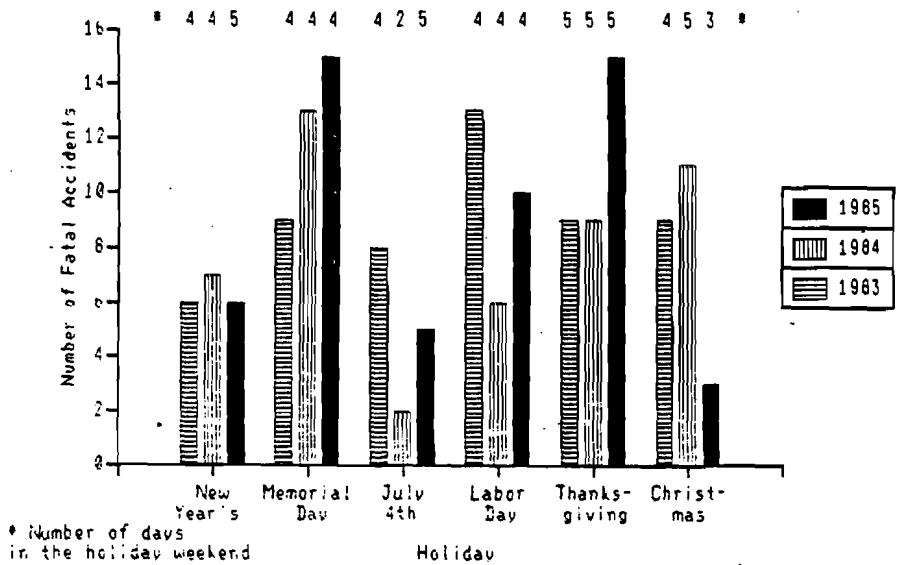

Holiday Alcohol Related Fatalities 1983-1985

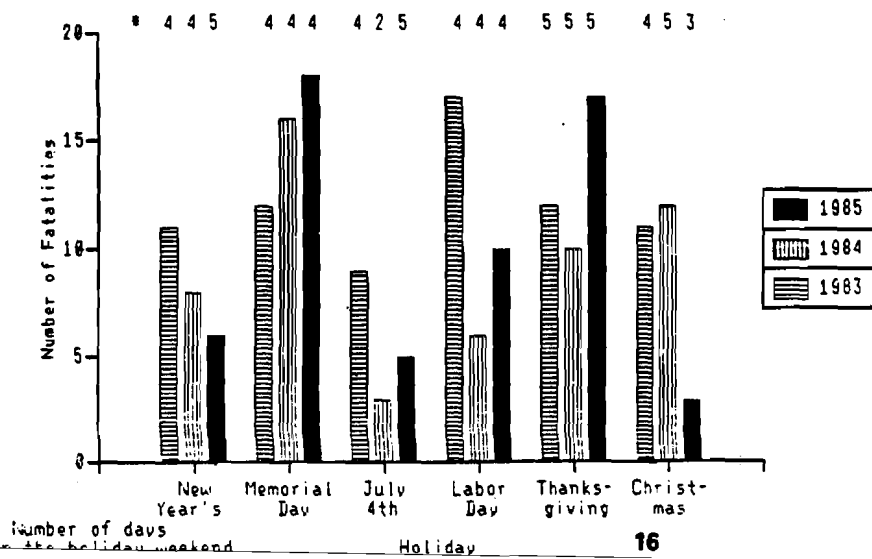

1985 PENNSYLVANIA DATA BY COUNTY MISCELLANEOUS ACCIDENT DATA

COUNTY	FATALITIES	% DEAD AT SCENE	TOTAL ACCIDENTS	% ACCIDENTS DRV < 21	% ALCOHOL ACCIDENTS DRV < 21	% LATE NITE WEEKEND ACCS
ADAMS	24	50.000	996	25.1924	21.4286	22.7273
ALLEGHENY	134	29.851	14263	17.1984	15.0998	13.0081
ARMSTRONG	7	42.847	679	18.9536	15.7895	14.2857
BEAVER	18	44.444	1819	18.7032	15.5367	18.7500
BEDFORD	13	30.769	619	19.8020	22.4299	33.3333
BERKS	73	27.397	4666	20.4946	15.3946	24.2424
BLAIR	11	27.273	1576	20.4121	18.8272	10.0000
BRADFORD	23	26.087	654	21.2789	11.9497	29.4118
BUCKS	96	30.208	8460	22.5568	17.2791	16.4706
BUTLER	27	44.444	1941	19.3981	14.6154	19.2308
CAMBRIA	17	23.529	1442	21.2924	20.4152	35.2941
CAMERON	1	0	78	13.9785	14.2857	0
CARBON	8	0	827	22.7550	19.2982	25.0000
CENTRE	24	25.000	1177	21.0526	19.6653	15.0000
CHESTER	70	32.857	5550	20.9406	17.4645	17.1875
CLARION	10	10.000	545	19.1411	20.1835	0
CLEARFIELD	18	27.778	1072	19.8227	13.3588	29.4118
CLINTON	11	18.182	404	20.4819	20.8333	9.0909
COLUMBIA	20	30.000	728	23.7179	14.3791	15.0000
CRAWFORD	21	19.048	1044	18.9017	13.7546	11.1111
CUMBERLAND	37	24.324	2463	23.7184	18.4584	11.4283
DAUPHIN	38	28.947	3245	18.7817	12.6856	20.5882
DELAWARE	58	25.862	6334	18.1999	14.7813	25.4902
ELK	9	66.667	393	18.6411	16.1616	33.3333
ERIE	49	22.449	3589	19.6416	16.6842	27.6596
FAYETTE	20	40.000	1645	20.1054	15.4412	11.7647
FOREST	1	100.000	101	17.9688	23.8095	0
FRANKLIN	18	16.667	1395	24.5506	17.9688	11.7647
FULTON	5	0	226	18.8612	6.2500	0
GREENE	6	16.667	402	21.2654	24.6154	20.0000
HUNTINGDON	16	37.500	470	22.9851	12.3596	7.1429
INDIANA	23	26.087	1097	19.3341	17.4797	11.1111
JEFFERSON	5	0	570	19.6517	17.3469	20.0000
JUNIATA	10	40.000	208	25.0000	29.7872	37.5000
LACKAWANNA	29	27.586	2657	20.9401	19.1617	22.2222
LANCASTER	60	21.667	4932	21.7556	15.3450	21.1538
LAWRENCE	15	13.333	999	18.7941	16.6667	23.0769
LEBANON	20	5.000	1466	22.8228	19.1419	5.2632
LEHIGH	37	35.135	4257	18.7335	17.9864	21.2121
LUZERNE	49	16.327	3802	23.1422	18.1013	25.0000
LYCOMING	21	28.571	1388	22.3168	15.4799	17.6471
MCKEAN	17	5.882	485	20.8270	17.7419	7.1429
MERCER	22	31.818	1494	19.3747	16.1017	15.7895
MIFFLIN	8	50.000	501	25.4282	20.5357	50.0000
MONROE	34	14.706	1841	20.1920	16.1512	10.7143
MONTGOMERY	83	27.711	10368	18.5555	15.8207	15.3846
MONTOUR	4	75.000	218	24.0625	16.2162	25.0000
NORTHAMPTON	27	14.815	2955	23.1133	19.8592	12.0000
NORTHUMBERLAND	21	33.333	861	24.6094	22.2973	15.7395
PERRY	15	26.667	525	25.8741	13.9535	0
PIKE	11	27.273	440	17.3835	23.9130	30.0000
POTTER	0	0	211	25.0951	16.2791	0
SCHUYLKILL	31	25.806	1663	22.6825	19.7411	22.2222
SNYDER	9	22.222	458	20.8333	8.7719	22.2222
SOMERSET	17	17.647	837	18.8055	24.7059	25.0000
SULLIVAN	1	100.000	101	13.1148	0	0
SUSQUEHANNA	6	66.667	431	19.5540	11.9048	25.0000
TIOGA	14	42.857	450	20.4800	13.1783	27.2727
UNION	11	45.455	360	24.4403	21.4286	11.1111
VENANGO	17	35.294	856	17.8370	13.8122	21.4286
WARREN	16	6.250	531	22.5201	20.9302	25.0000
WASHINGTON	33	33.333	2447	19.2265	13.7681	39.2857
WAYNE	12	25.000	455	25.8824	22.4138	20.0000
WESTMORELAND	77	31.169	4447	19.1779	16.2875	14.9254
WYOMING	4	0	383	22.9730	19.7802	0
YORK	44	20.455	4426	24.7103	16.1734	23.0769
PHILADELPHIA	123	23.577	15321	12.8612	9.2038	20.7207

1985 PENNSYLVANIA ACCIDENTS BY COUNTY

COUNTY	FATAL ACCIDENTS	INJURY ACCIDENTS	P.D.O. ACCIDENTS	TOTAL ACCIDENTS
ADAMS	22	608	366	996
ALLEGHENY	123	8605	5535	14263
ARMSTRONG	7	435	237	679
BEAVER	16	1138	665	1819
BEDFORD	12	392	215	619
BERKS	66	2773	1827	4666
BLAIR	10	1018	548	1576
BRADFORD	17	417	220	654
BUCKS	85	5411	2964	8460
BUTLER	26	1214	701	1941
CAMBRIA	17	913	512	1442
CAMERON	1	47	30	78
CARBON	8	493	326	827
CENTRE	20	730	427	1177
CHESTER	64	3440	2046	5550
CLARION	8	358	179	545
CLEARFIELD	17	683	372	1072
CLINTON	11	257	136	404
COLUMBIA	20	477	231	728
CRAWFORD	18	657	369	1044
CUMBERLAND	35	1461	967	2463
DAUPHIN	34	1985	1226	3245
DELAWARE	51	4178	2105	6334
ELK	6	241	146	393
ERIE	47	2496	1046	3589
FAYETTE	17	1130	498	1645
FOREST	1	71	29	101
FRANKLIN	17	885	493	1395
FULTON	3	130	93	226
GREENE	5	275	122	402
HUNTINGDON	14	289	167	470
INDIANA	18	737	342	1097
JEFFERSON	5	374	191	570
JUNIATA	8	131	69	208
LACKAWANNA	27	1748	882	2657
LANCASTER	52	3241	1639	4932
LAWRENCE	13	669	317	999
LEBANON	19	920	527	1466
LEHIGH	33	2779	1445	4257
LUZERNE	48	2437	1317	3802
LYCOMING	17	930	441	1388
MCKEAN	14	292	179	485
MERCER	19	916	559	1494
MIFFLIN	6	322	173	501
MONROE	28	1123	690	1841
MONTGOMERY	78	6785	3505	10368
MONTOUR	4	133	81	218
NORTHAMPTON	25	1879	1051	2955
NORTHUMBERLAND	19	574	268	861
PERRY	11	344	170	525
PIKE	10	272	158	440
POTTER	-	141	70	211
SCHUYLKILL	27	1100	536	1663
SNYDER	9	284	165	458
SOMERSET	16	542	279	837
SULLIVAN	1	69	31	101
SUSQUEHANNA	4	284	143	431
TIOGA	11	303	136	450
UNION	9	248	103	360
VENANGO	14	578	264	856
WARREN	12	340	179	531
WASHINGTON	28	1503	916	2447
WAYNE	10	324	121	455
WESTMORELAND	67	2804	1576	4447
WYOMING	4	254	125	383
YORK	39	2879	1508	4426
PHILADELPHIA	111	11974	3236	15321
TOTAL	1614	93440	48190	143244

**1985 PENNSYLVANIA DATA BY COUNTY
FATALITIES AND INJURIES AND RATES/10,000 POPULATION**

COUNTY	FATALITIES	FATALITIES PER 10,000 POPULATION	FATALITIES PLUS INJURIES	FAT. + INJ. PER 10,000 POPULATION	TOTAL ACCIDENTS	POPULATION
ADAMS	24	3.42085	895	125.569	996	70158
ALLEGHENY	134	0.93177	12647	87.941	14263	1438120
ARMSTRONG	7	0.89583	658	84.208	679	78140
BEAVER	18	0.88885	1719	84.886	1819	202508
BEDFORD	13	2.72354	627	131.358	619	47732
BERKS	73	2.31949	4195	133.291	4666	314724
BLAIR	11	0.80968	1540	113.355	1576	135856
BRADFORD	23	3.59375	651	101.719	654	64000
BUCKS	96	1.93726	8341	168.320	8460	495545
BUTLER	27	1.80255	1867	124.643	1941	1495545
CAMBRIA	17	0.94856	1387	77.391	1442	179219
CAMERON	1	1.47167	70	103.017	78	6795
CARBON	8	1.48176	771	142.804	827	53990
CENTRE	24	2.10976	1113	97.840	1177	113757
CHESTER	70	2.14819	5250	161.114	5550	325856
CLARION	10	2.31997	563	130.614	545	43104
CLEARFIELD	18	2.17085	1019	122.894	1072	82917
CLINTON	11	2.83673	386	99.544	404	38777
COLUMBIA	20	3.22617	736	118.723	728	61993
CRAWFORD	21	2.34532	1010	112.799	1044	89540
CUMBERLAND	37	2.02996	2200	127.937	3245	234256
DAUPHIN	38	1.62216	2997	127.937	3245	234256
DELAWARE	58	1.05213	6244	113.267	6334	551264
ELK	9	2.36755	356	93.650	393	38014
ERIE	49	1.74279	3841	136.614	3589	281158
FAYETTE	20	1.26480	1766	111.682	1645	158128
FOREST	1	1.99084	123	244.874	101	5023
FRANKLIN	18	1.56120	1316	114.141	1395	115296
FULTON	5	3.77188	202	152.384	226	13256
GREENE	6	1.46875	398	97.427	402	40851
HUNTINGDON	16	3.75746	445	104.504	470	42582
INDIANA	23	2.47586	1179	126.915	1097	92897
JEFFERSON	5	1.03118	546	112.605	570	48488
JUNIATA	10	5.14933	205	105.561	208	19420
LACKAWANNA	29	1.28594	2728	120.967	2657	225516
LANCASTER	60	1.61311	4904	131.845	4932	371952
LAWRENCE	15	1.41084	993	93.397	999	106320
LEBANON	20	1.80483	1416	151.322	4257	274977
LEHIGH	37	1.34557	4161	151.322	4257	274977
LUZERNE	49	1.44193	3667	107.909	3802	339823
LYCOMING	21	1.78969	1462	124.596	1388	117339
MCKEAN	17	3.43587	420	84.886	485	49478
MERCER	22	1.72569	1436	112.641	1494	127485
MIFFLIN	8	1.72269	503	108.314	501	46439
MONROE	34	4.64728	1765	241.249	1841	73161
MONTGOMERY	83	1.27422	10427	160.076	10368	651379
MONTOUR	4	2.37713	189	112.319	218	16827
NORTHAMPTON	27	1.18259	2725	119.354	2955	228312
NORTHUMBERLAND	21	2.09245	899	89.577	861	100361
PERRY	15	4.10374	519	141.989	525	36552
PIKE	11	5.62458	439	224.472	440	19557
POTTER	0	0	0	0	211	17842
SCHUYLKILL	31	1.95242	1734	109.210	1663	158777
SNYDER	9	2.62728	450	131.364	458	34256
SOMERSET	17	2.08298	835	102.311	837	81614
SULLIVAN	1	1.57828	101	159.407	101	6336
SUSQUEHANNA	6	1.57762	436	114.640	431	38032
TIOGA	14	3.41597	485	118.339	450	40984
UNION	11	3.28378	399	119.112	360	33498
VENANGO	17	2.61547	906	139.389	856	64998
WARREN	16	3.34050	517	107.940	531	47897
WASHINGTON	33	1.51781	2214	101.831	2447	217419
WAYNE	12	3.29290	525	144.065	455	36442
WESTMORELAND	77	1.96697	4441	113.445	4447	391466
WYOMING	4	1.49555	378	141.330	383	26746
YORK	44	1.38762	4275	134.820	4426	317089
PHILADELPHIA	134	0.73857	18079	108.558	15321	1665382

1985 FATALITY RATES PER 10,000 POPULATION PENNSYLVANIA STATE HIGHWAY ENGINEERING DISTRICTS

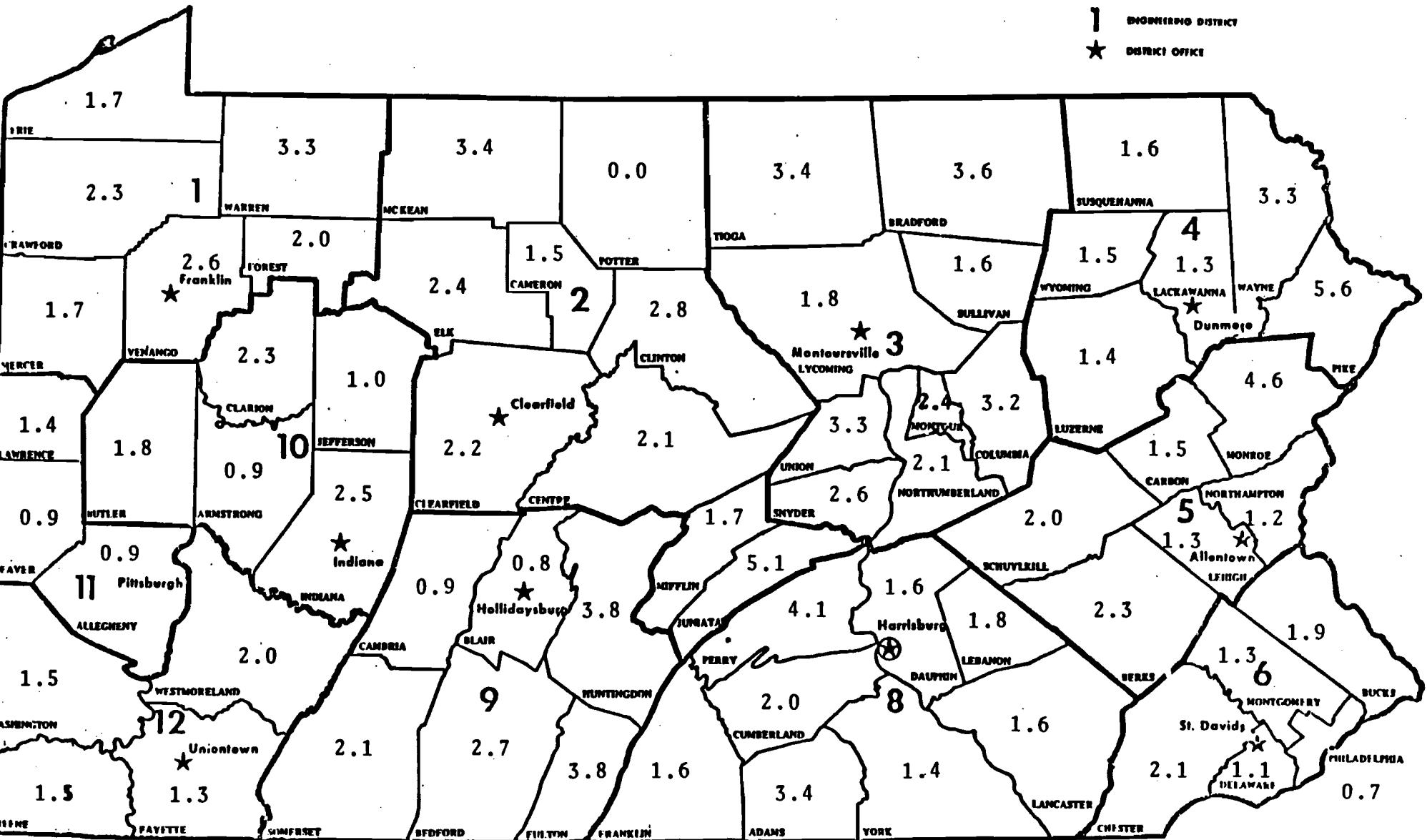

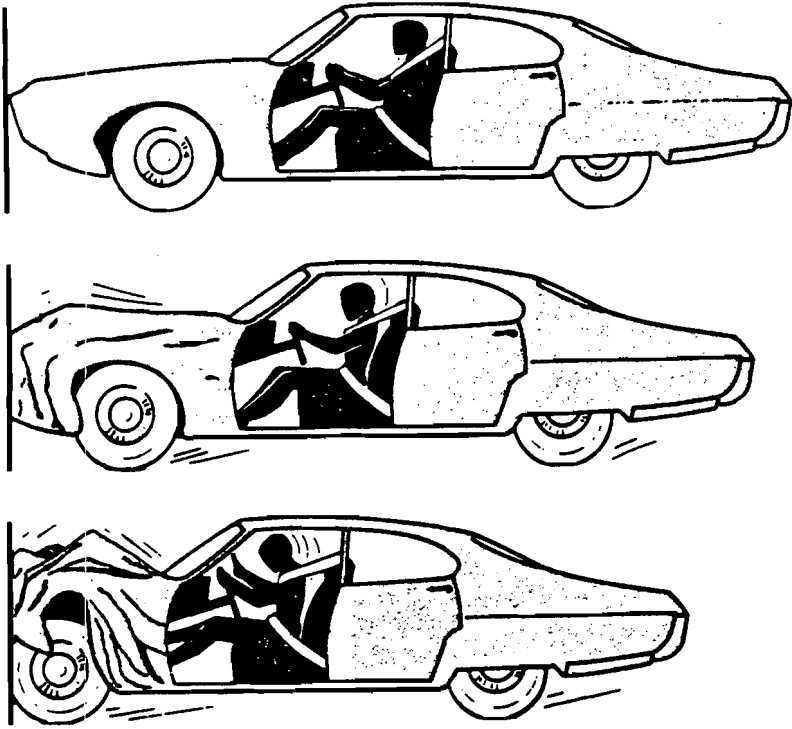

FATALITY and INJURY CHARACTERISTICS

1985

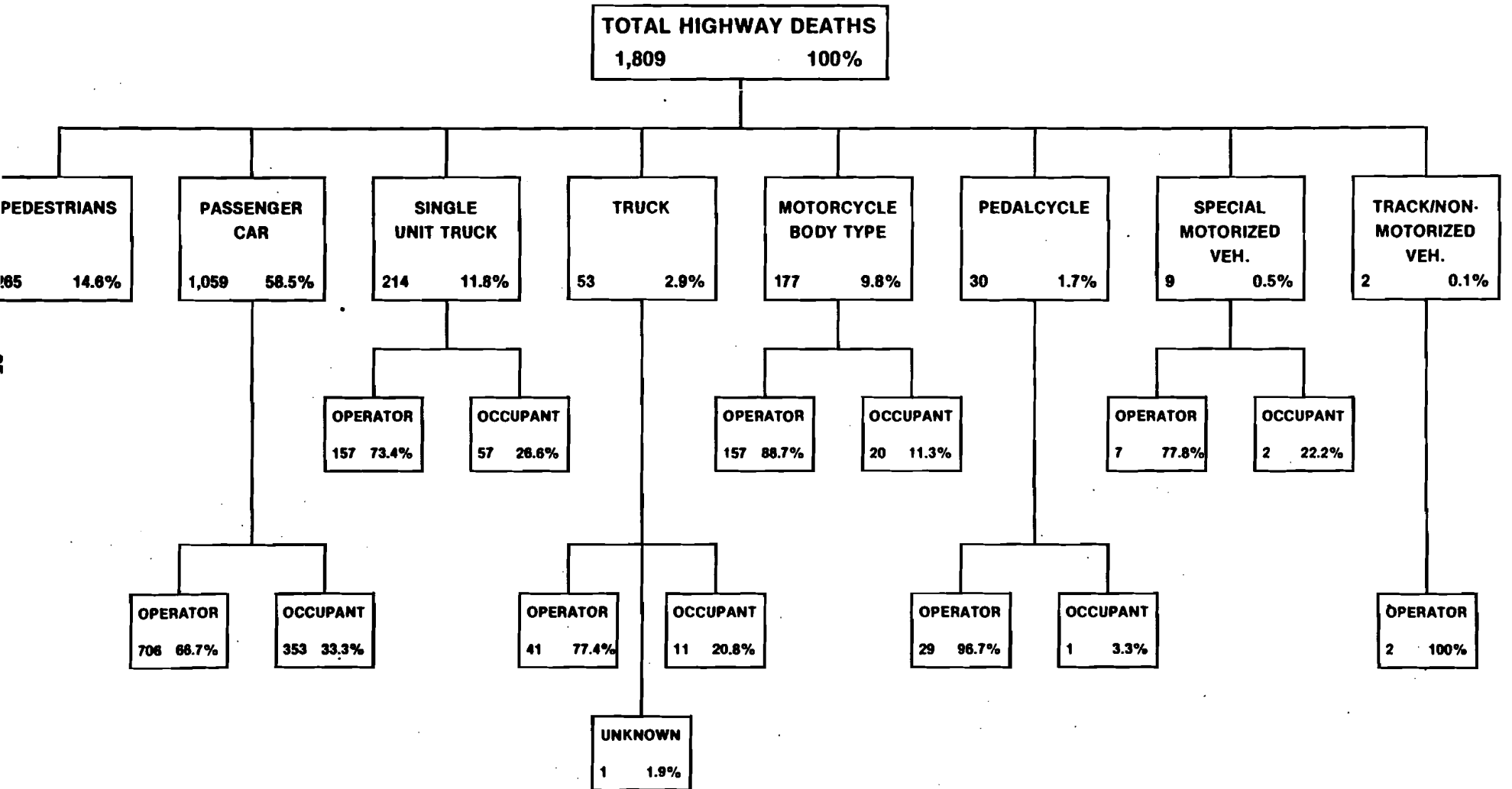

Pedestrian Deaths Distribution by Age and Sex* 1985 Accidents

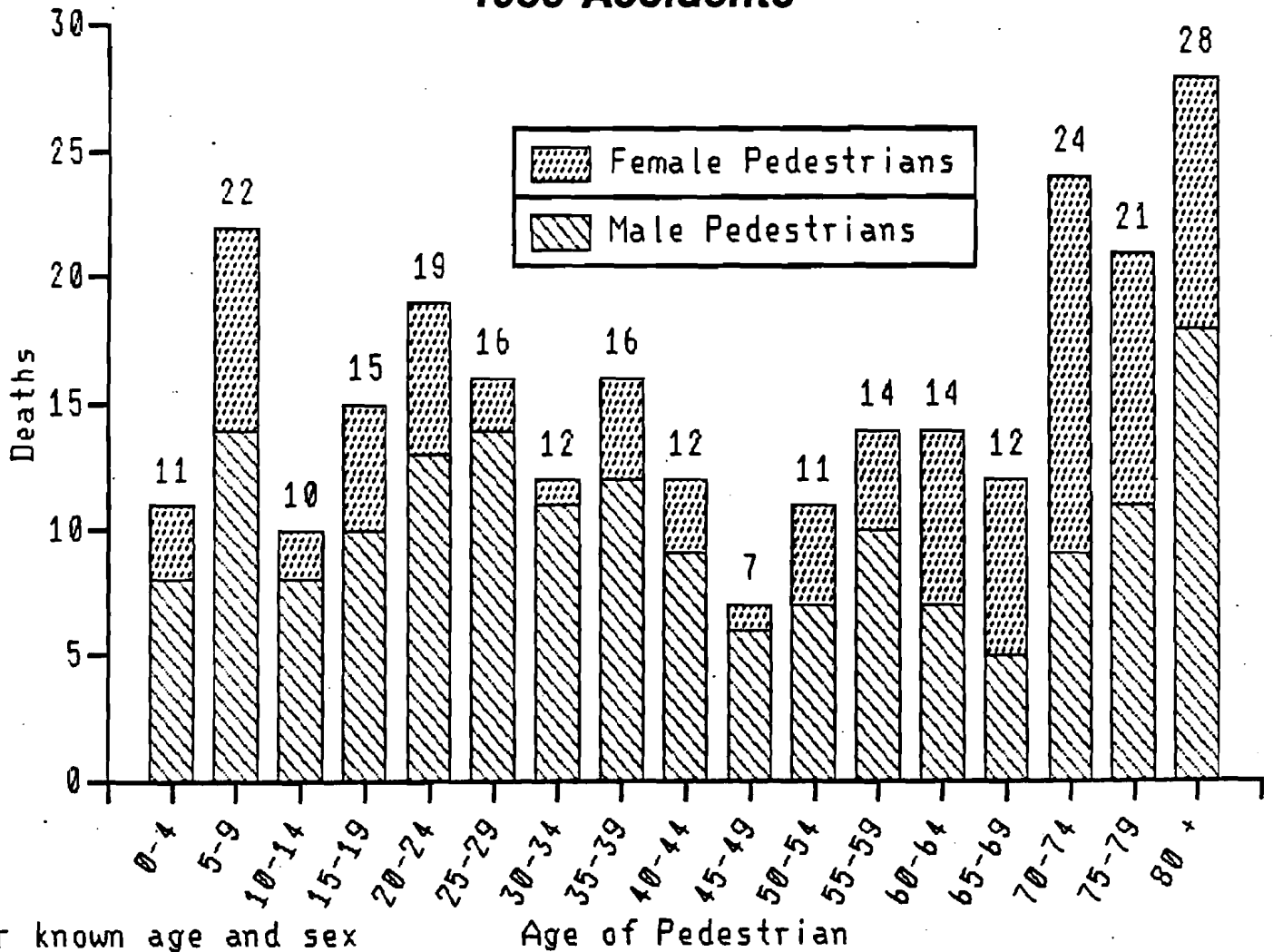

* For known age and sex

1985 Highway Deaths By Age and Sex

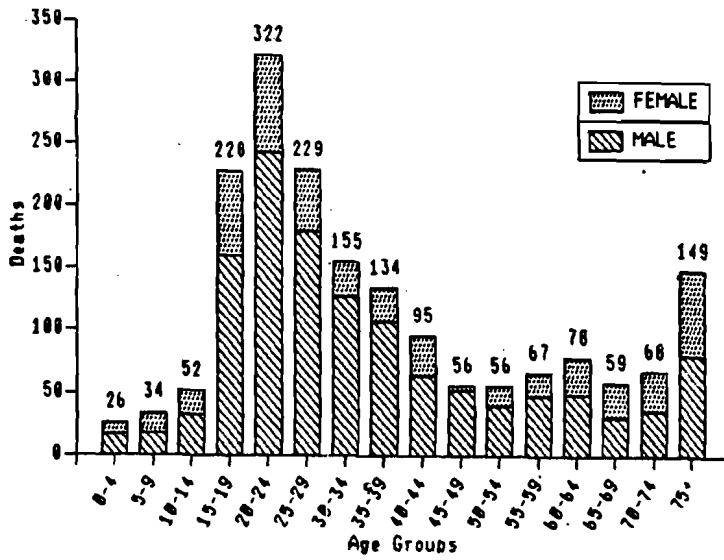

1985

Vehicle Operator Deaths Distribution by Age and Sex

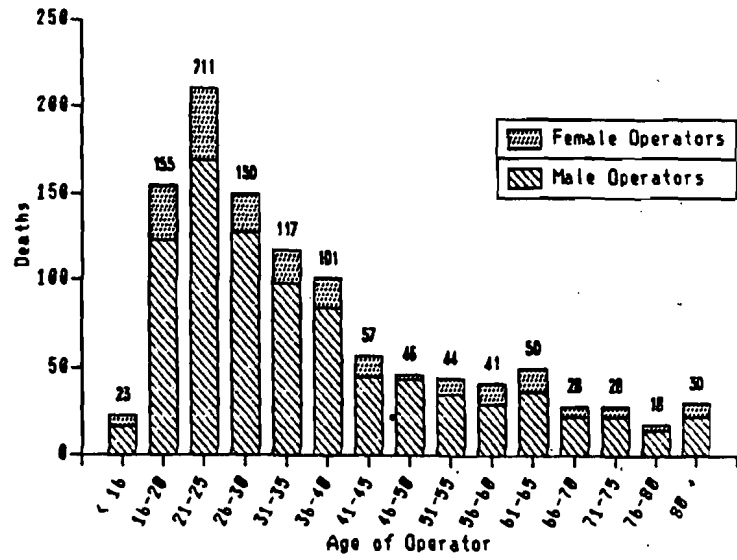

1985

Vehicle Occupant Deaths Distribution by Age and Sex

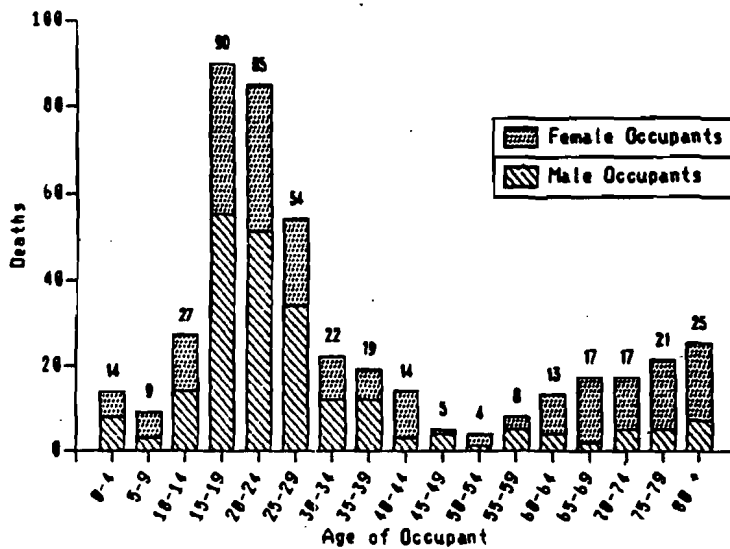

1985 Major Injuries By Age and Sex

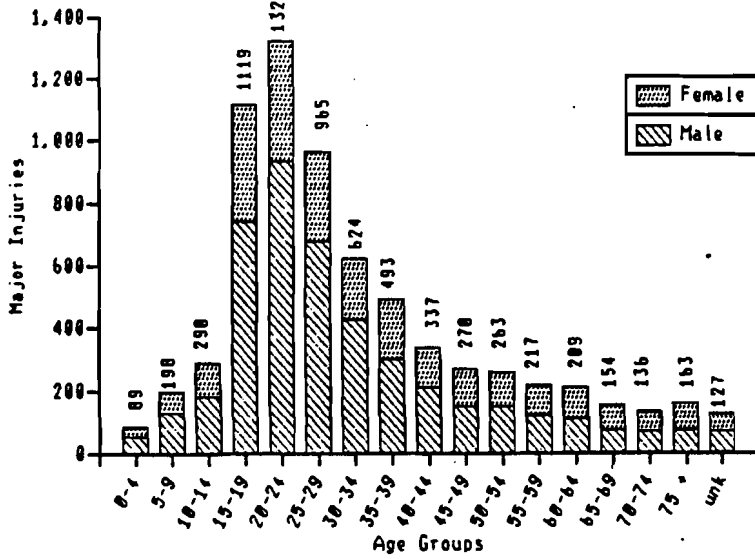

1985 Moderate Injuries By Age and Sex

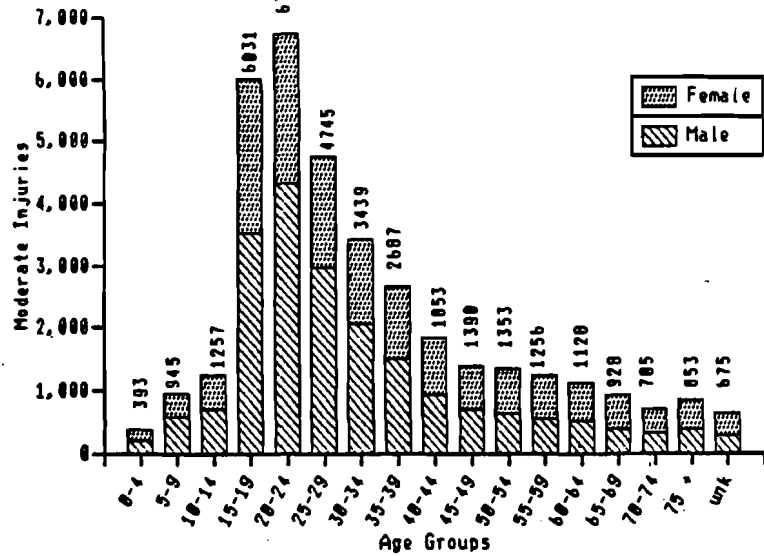

1985 Minor Injuries By Age and Sex

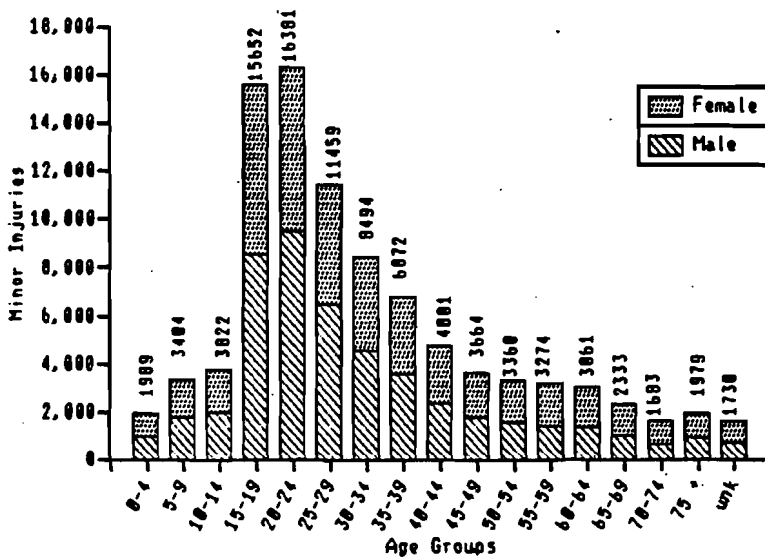

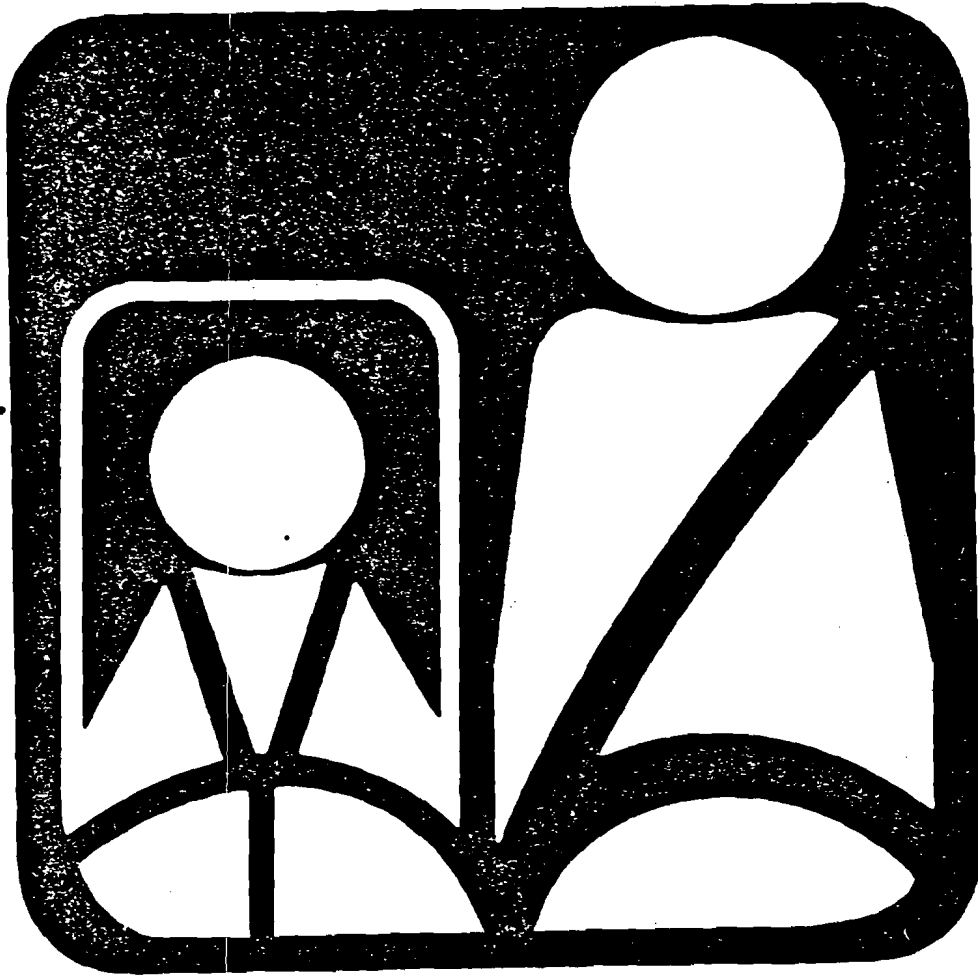

SEAT BELT STATISTICS

1985

ACCIDENTS IN WHICH SEAT BELT USAGE WAS KNOWN

TOTAL PEOPLE*
212,003 100%

PASSENGER CARS
172,477 81.4%

SINGLE UNIT TRUCKS
33,545 15.8%

TRUCKS
59.81 2.8%

BELTS IN USE
53,038 30.8%

BELTS NOT IN USE**
119,439 69.2%

BELTS IN USE
2,353 39.3%

BELTS NOT IN USE**
3,628 60.7%

Killed	78	0.2%
Major Injury	451	0.9%
Moderate Injury	3,122	5.9%
Minor Injury	13,538	25.5%
No Injury	35,727	67.4%
Unknown Injury	122	0.2%

Killed	654	0.5%
Major Injury	2,349	2.0%
Moderate Injury	13,228	11.1%
Minor Injury	35,406	29.6%
No Injury	87,458	58.5%
Unknown Injury	346	0.3%

Killed	3	0.1%
Major Injury	21	1.0%
Moderate Injury	111	4.7%
Minor Injury	460	19.5%
No Injury	1,757	74.7%
Unknown Injury	1	0.0%

Killed	28	0.8%
Major Injury	64	1.8%
Moderate Injury	268	7.4%
Minor Injury	595	16.4%
No Injury	2,668	73.5%
Unknown Injury	5	0.1%

BELTS IN USE
7,731 23.0%

BELTS NOT IN USE**
25,814 77.0%

Killed	8	0.1%
Major Injury	51	0.7%
Moderate Injury	360	4.7%
Minor Injury	1,581	20.5%
No Injury	5,720	74.0%
Unknown Injury	11	0.1%

Killed	132	0.5%
Major Injury	450	1.7%
Moderate Injury	2,270	8.8%
Minor Injury	6,123	23.7%
No Injury	16,778	65.0%
Unknown Injury	61	0.2%

* INCLUDES NON-PARKED PASSENGER CAR, SINGLE UNIT TRUCK, AND TRUCK OPERATORS AND OCCUPANTS WHOSE SEAT BELT USE IS KNOWN, INVOLVED IN REPORTABLE ACCIDENTS. DOES NOT INCLUDE ACCIDENTS IN WHICH SEAT BELT USE IS UNKNOWN.

** INCLUDES BELTS NOT IN USE AND BELTS NOT AVAILABLE.

1985

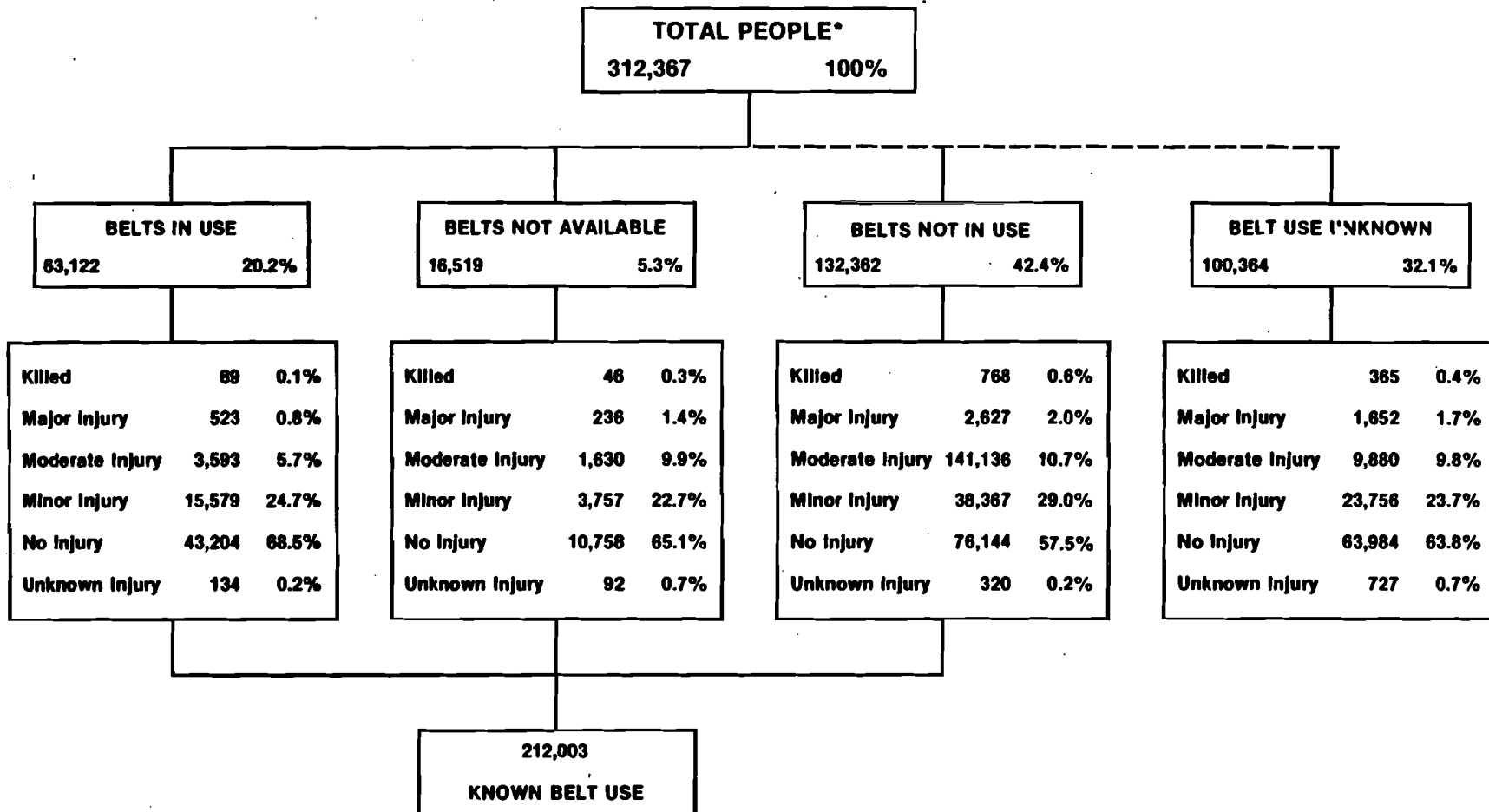

* INCLUDES NON-PARKED PASSENGER CAR, SINGLE UNIT TRUCK, AND TRUCK OPERATORS AND OCCUPANTS INVOLVED IN REPORTABLE ACCIDENTS.

1985

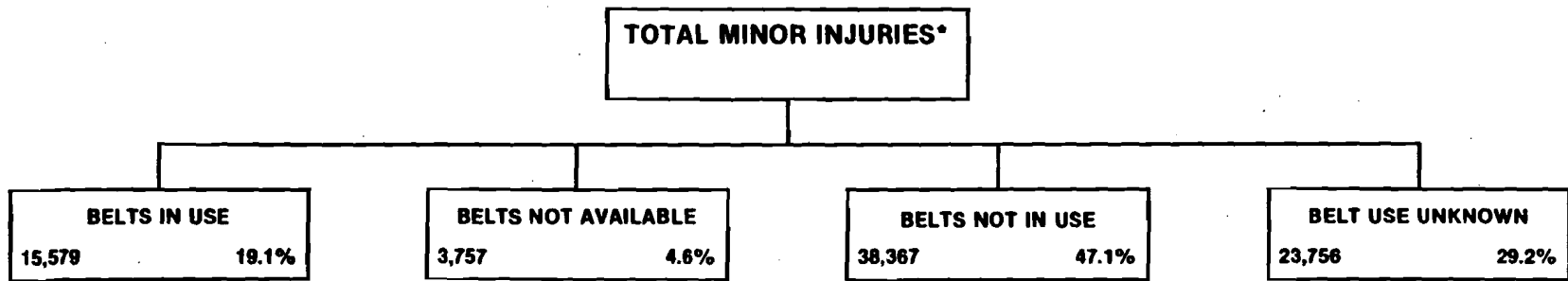
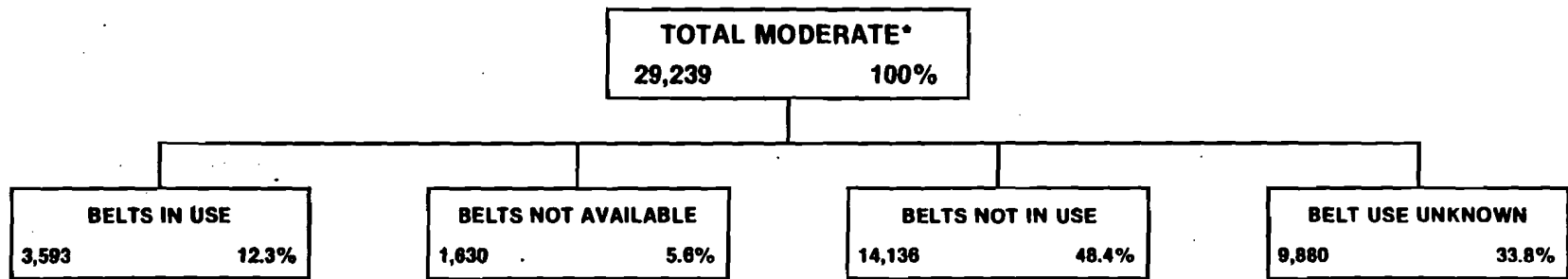
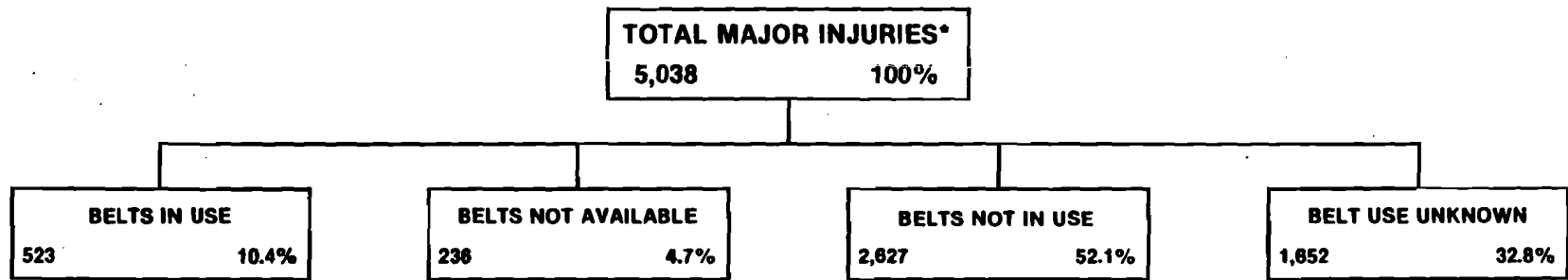
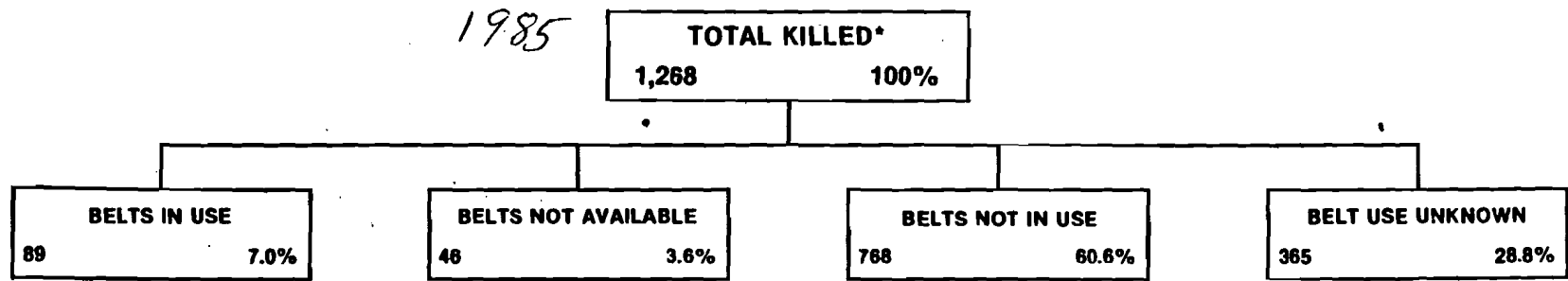

* INCLUDES ALL NON-PARKED PASSENGER CAR, SINGLE UNIT TRUCK AND TRUCK OPERATORS AND OCCUPANTS IN REPORTABLE ACCIDENTS.

**IMPACT OF 100% BELT USE ON
1985 FATALITIES & INJURIES —
PASSENGER CARS ONLY**

	SUM					
	KILLED	MAJOR INJURY	MODERATE INJURY	MINOR INJURY	NO INJURY	TOTAL PERSONS
NO BELTS	36	161	1,243	2,789	6,814	11,043
BELTS USED	74	426	2,970	12,628	31,363	47,461
BELTS NOT USED	599	2,095	11,593	31,639	56,713	102,639
USE UNKNOWN	211	845	4,572	10,639	23,228	39,495
TOTAL	920	3,527	20,378	57,695	118,118	200,638
EXPECTED 100% USE	366	2,032	13,272	53,510	130,285	-
NET GAIN/LOSS	- 552	- 1,486	- 7,062	- 4,036	12,581	-

Percent of People Involved in Accidents Wearing Seat Belts 1983-1985

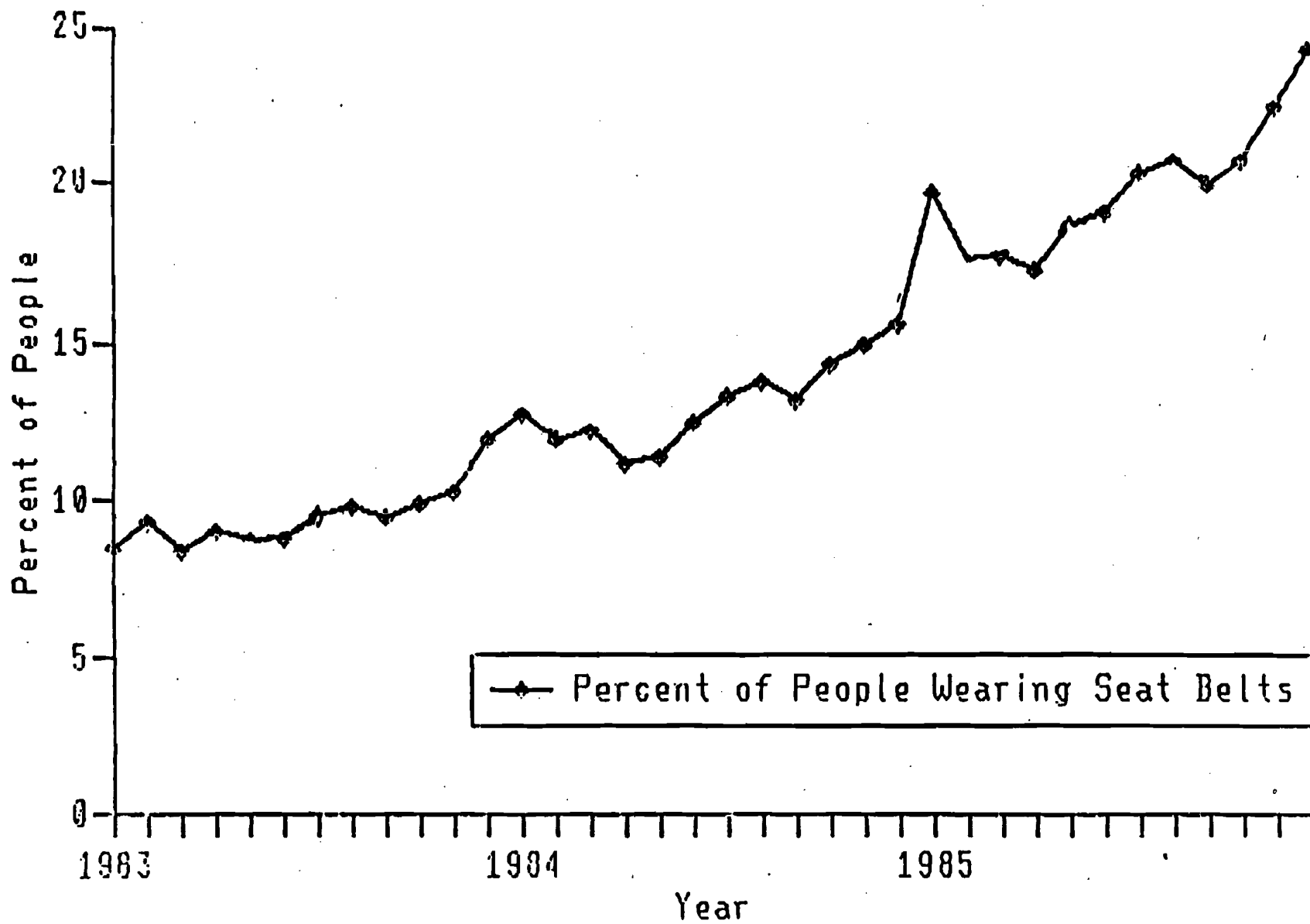

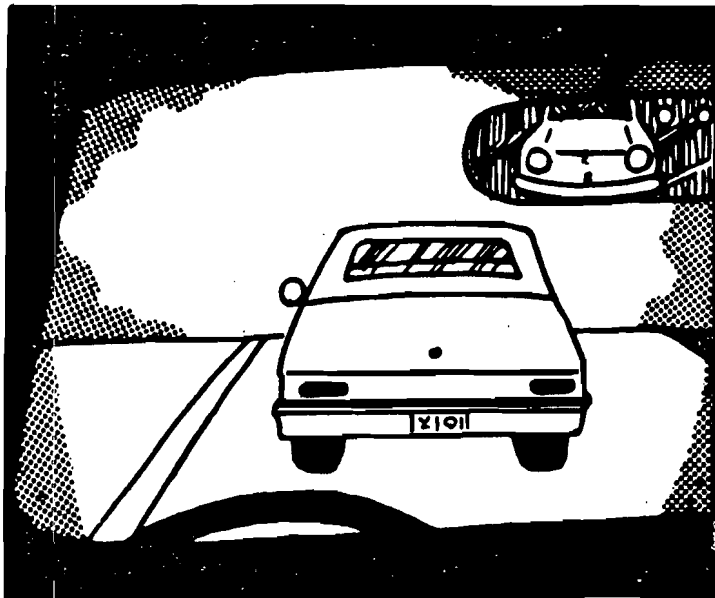

DRIVER and VEHICLE CHARACTERISTICS

1985 PENNSYLVANIA SPEED RELATED ACCIDENTS BY COUNTY

COUNTY	FATAL ACCIDENTS	INJURY ACCIDENTS	P.D.O. ACCIDENTS	TOTAL ACCIDENTS
ADAMS	4	52	29	85
ALLEGHENY	17	241	113	371
ARMSTRONG	2	20	12	34
BEAVER	3	33	22	58
BEDFORD	2	43	21	66
BERKS	13	205	115	333
BLAIR	2	43	22	67
BRADFORD	5	37	9	51
BUCKS	22	100	62	184
BUTLER	6	98	48	152
CAMBRIA	5	45	19	69
CAMERON	1	5	0	6
CARBON	2	53	23	78
CENTRE	7	49	13	69
CHESTER	14	296	148	458
CLARION	3	57	21	81
CLEARFIELD	3	79	34	116
CLINTON	1	18	5	24
COLUMBIA	9	34	14	57
CRAWFORD	5	76	29	110
CUMBERLAND	11	109	49	169
DAUPHIN	11	116	48	175
DELAWARE	6	159	72	237
ELK	1	30	11	42
ERIE	8	229	84	321
FAYETTE	8	123	39	170
FOREST	0	9	5	14
FRANKLIN	7	54	22	83
FULTON	1	15	8	24
GREENE	0	29	18	47
HUNTINGDON	4	21	7	32
INDIANA	2	39	22	63
JEFFERSON	0	35	17	52
JUNIATA	4	21	10	35
LACKAWANNA	8	71	31	110
LANCASTER	8	287	148	443
LAWRENCE	4	61	19	84
LEBANON	5	109	47	161
LEHIGH	5	193	88	286
LUZERNE	7	54	35	96
LYCOMING	5	49	26	80
MCKEAN	3	17	9	29
MERCER	4	9	5	18
MIFFLIN	4	18	14	36
MONROE	6	66	38	110
MONTGOMERY	17	487	250	754
MONTOUR	0	15	12	27
NORTHAMPTON	7	124	67	198
NORTHUMBERLAND	5	56	21	82
PERRY	5	54	22	81
PIKE	5	49	18	72
POTTER	0	9	6	15
SCHUYLKILL	5	99	44	148
SNYDER	0	25	10	35
SOMERSET	4	42	12	58
SULLIVAN	0	15	1	16
SUSQUEHANNA	1	35	7	43
TIOGA	3	55	16	74
UNION	2	28	9	39
VENANGO	6	41	15	62
WARREN	2	21	11	34
WASHINGTON	6	102	67	175
WAYNE	1	40	10	51
WESTMORELAND	18	277	121	416
WYOMING	1	28	12	41
YORK	14	287	147	448
PHILADELPHIA	3	27	20	50
TOTAL	353	5423	2539	8305

1985

TOTAL NUMBER OF OPERATORS INVOLVED IN AN ACCIDENT
246,026 100%

INVOLVED IN FATAL ACCIDENTS
2,534 1.0%

INVOLVED IN INJURY ACCIDENTS
162,949 66.2%

INVOLVED IN P.D.O ACCIDENTS
80,543 32.7%

PENNSYLVANIA LICENSE
2,071 81.7%

NO LICENSE
48 1.9%

PENNSYLVANIA LICENSE
134,622 82.6%

NO LICENSE
1,673 1.0%

PENNSYLVANIA LICENSE
64,897 80.6%

NO LICENSE
686 0.9%

Non-Pennsylvania LICENSE
266 10.5%

NOT APPLICABLE
111 4.4%

Non-Pennsylvania LICENSE
12,046 7.4%

NOT APPLICABLE
9,827 6.0%

Non-Pennsylvania LICENSE
6,465 8.0%

NOT APPLICABLE
6,275 7.8%

UNKNOWN LICENSE
38 1.5%

UNKNOWN LICENSE
4,781 2.9%

UNKNOWN LICENSE
2,220 2.8%

1985

YOUNG DRIVERS IN ACCIDENTS

Drivers 16 to 18 accounted for 9.95% of the drivers involved in Pennsylvania's 1985 reportable accidents, although they represent only 3.80% of Pennsylvania's licensed drivers. The age group 16 to 18 has an accident involvement rate of approximately 81 accidents per 1000 drivers, as compared to a rate of 31 involvement of young (age 16 to 18) drivers in 1985 Pennsylvania traffic accidents.

**INVOLVEMENT OF 16 to 18 YEAR OLD DRIVERS IN
1985 PENNSYLVANIA TRAFFIC ACCIDENTS**

	Accidents	Alcohol Related Accidents
--Fatal	206	52
--Injury	14,759	829
--P.D.O.	8,252	425
TOTAL	23,217	1,306

HIGH COUNTIES — TOTAL ACCIDENTS

County	Accidents	County	Alcohol Related
Allegheny	2,072	Allegheny	133
Montgomery	1,772	Montgomery	96
Bucks	1,748	Chester	63
Philadelphia	1,075	Bucks	59
Chester	1,040	Westmoreland	55
Delaware	1,017	Delaware	51
York	1,010		

HIGH COUNTIES — FATAL ACCIDENTS

County	Accidents	County	Alcohol Related
Berks	14	Montgomery	6
Montgomery	14	Berks	5
Bucks	11	Bucks	4
Lancaster	9	Allegheny	3

TOTAL ACCIDENTS BY MONTHS

Month	Accidents	Month	Alcohol Related
November	2,351	November	132
June	2,268	August	130
July	2,187	May	121
October	2,095	June	121
May	2,088	July	121
August	2,078	September	116
December	1,993	April	115
September	1,837	March	112
January	1,749	October	105
April	1,688	December	91
March	1,549	January	80
February	1,334	February	62

1985

YOUNG DRIVERS IN ACCIDENTS

HIGH HOUR PERIODS

4:00 P.M. - 8:00 P.M.
8:00 P.M. - Midnight
Noon - 4:00 P.M.

TOTAL ACCIDENTS

6,466
5,529
5,461

HIGH HOUR PERIODS

Midnight - 4:00 A.M.
8:00 P.M. - Midnight

ALCOHOL RELATED ACCIDENTS

520
508

DAYS

Friday
Saturday
Thursday
Sunday
Wednesday
Tuesday
Monday

TOTAL ACCIDENTS

4,620
4,252
3,153
2,992
2,815
2,721
2,664

DAYS

Saturday
Sunday
Friday
Thursday
Wednesday
Tuesday
Monday

ALCOHOL RELATED ACCIDENTS

400
240
226
124
114
110
92

DAY

HOUR PERIODS

Friday 8:00 P.M. - Midnight
Friday 4:00 P.M. - 8:00 P.M.
Saturday 8:00 P.M. - Midnight
Friday Noon - 4:00 P.M.

TOTAL ACCIDENTS

1,402
1,303
1,207
1,010

DAY

HOUR PERIODS

Saturday Midnight - 4:00 A.M.
Sunday Midnight - 4:00 A.M.
Saturday 8:00 P.M. - Midnight
Friday 8:00 P.M. - Midnight

ALCOHOL RELATED ACCIDENT

184
148
146
137

1985

YOUNG DRIVERS IN ACCIDENTS

	TOTAL ACCIDENTS	ALCOHOL RELATED ACCIDENTS
KILLED		
Total Killed	238	65
Drivers 16-18	80	33
--Male	--63	--27
--Female	--17	--6
Others 16-18	43	17
Total 16-18	123	50

DRIVERS INVOLVED

Total 16-18	23,217	1,306
--Age 16	--5,777 (24.9%)	--161 (12.3%)
--Age 17	--8,116 (35.0%)	--398 (30.5%)
--Age 18	--9,324 (40.2%)	--747 (57.2%)
--Male	--16,068 (69.2%)	--1,118 (85.6%)
--Female	--7,149 (30.8%)	--188 (14.4%)

DRIVER POPULATION

NUMBER OF DRIVERS

Age 16-18	287,035 (3.8% all drivers)
--Male	158,360 (2.1% all drivers) (4.0% all male drivers)
--Female	128,657 (1.7% of all drivers) (3.6% all female drivers)
--Age 16	51,957 (0.4% all drivers)
--Male	--29,504
--Female	--22,453
--Age 17	106,389 (1.4% all drivers)
--Male	--58,586
--Female	--47,803
--Age 18	128,689 (1.7% all drivers)
--Male	70,270
--Female	58,419

1985

Vehicle Involvement in Accidents

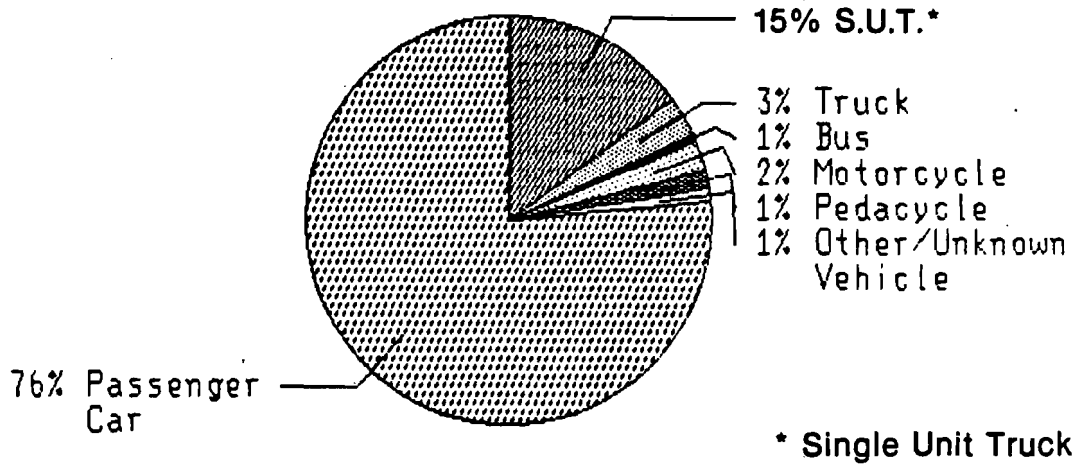

1985

Vehicle Involvement in Fatal Accidents

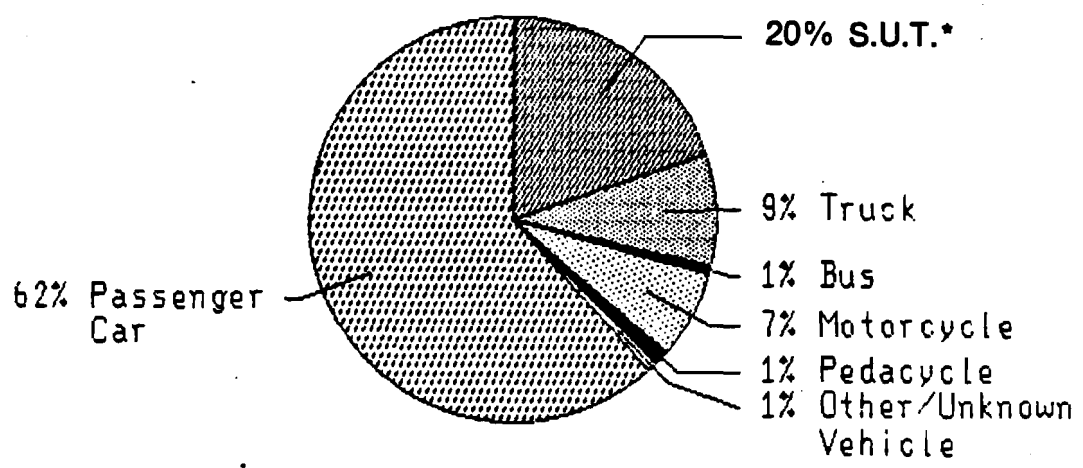

*Single Unit Truck

1985

**Percent of Operators in All Accidents*
vs
Percent of Operators Killed in Accidents
by Vehicle Type**

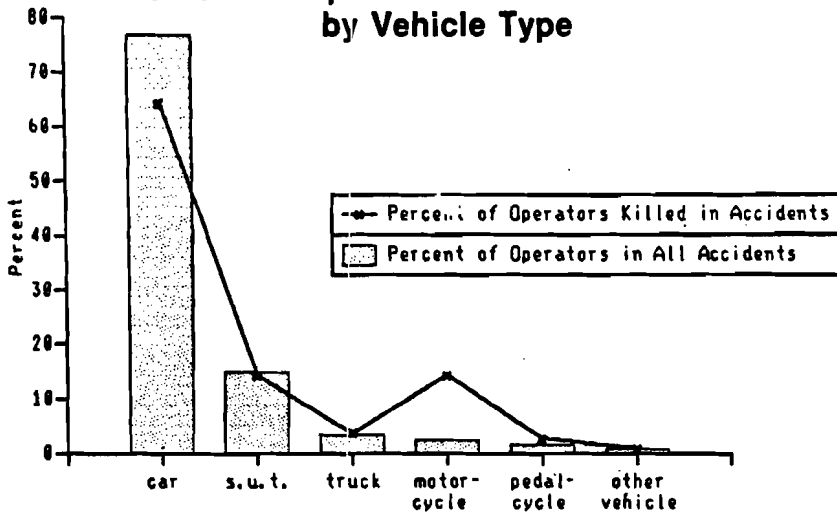

*Does not include operators of unknow vehicles

**Single unit truck

1985

**Speed Related Fatal Crashes
Age and Sex of Operator Speeding**

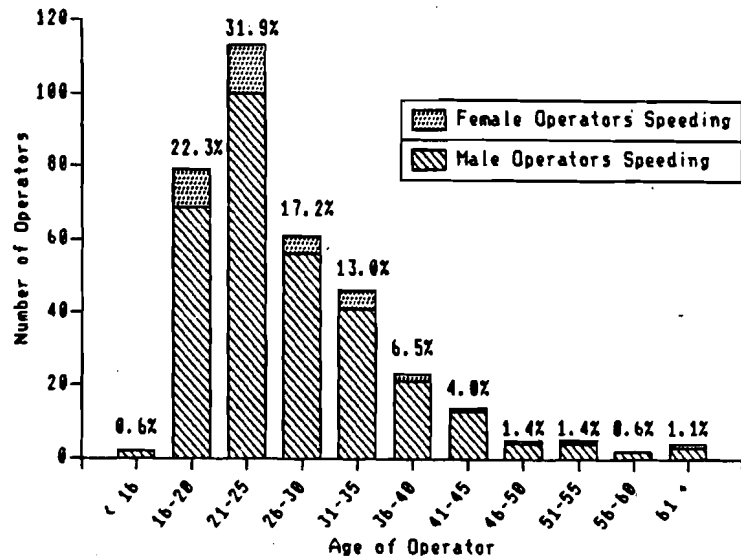

1985

**Speed Related Crashes
Age and Sex of Operator Speeding**

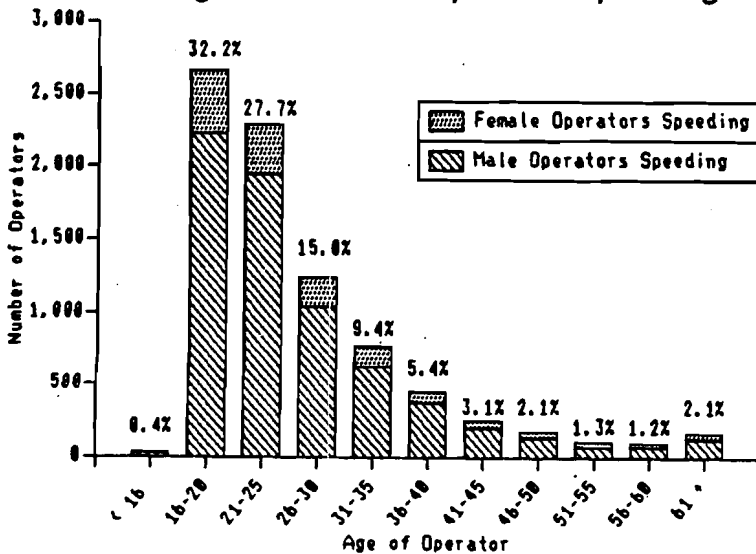



ALCOHOL INVOLVEMENT IN ACCIDENTS

1985

ALCOHOL INVOLVEMENT IN ACCIDENTS

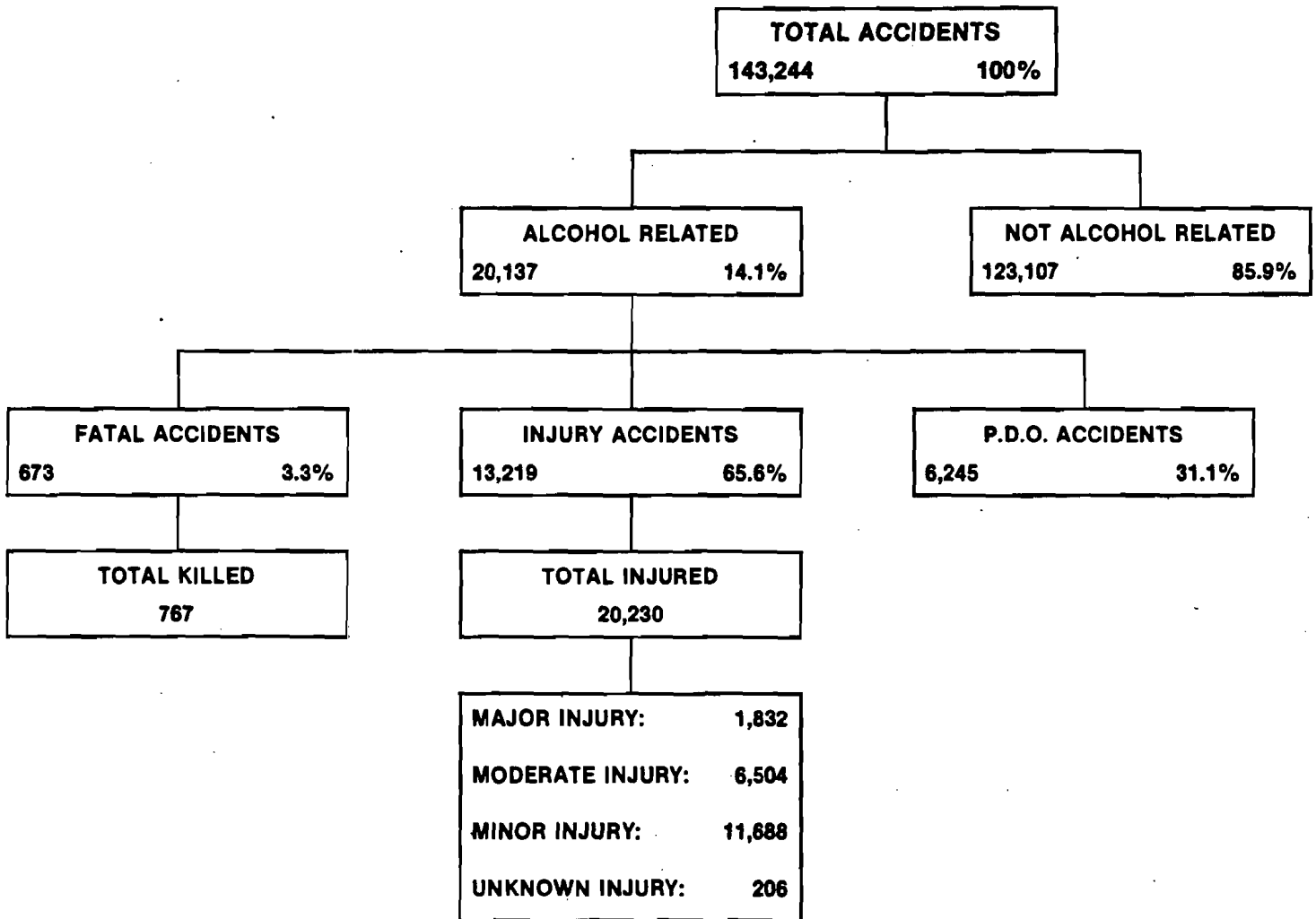

ECONOMIC LOSS DUE TO ALCOHOL RELATED ACCIDENTS = \$525,677,682.00

THE ECONOMIC LOSS TO EVERY MAN, WOMAN, AND CHILD IN PENNSYLVANIA DUE TO ALCOHOL RELATED ACCIDENTS IN 1985 WAS \$42.00.

1985

ALCOHOL RELATED ACCIDENTS
20,137 100%

DAY
3,154 15.7%

UNKNOWN
4 0%

NIGHT
16,979 84.3%

FATAL ACCIDENTS
117 3.7%

INJURY ACCIDENTS
2,207 70.0%

P.D.O. ACCIDENTS
830 26.3%

FATAL ACCIDENTS
556 3.3%

INJURY ACCIDENTS
11,009 64.8%

P.D.O. ACCIDENTS
5,414 31.9%

TOTAL KILLED
133

Major Injury 346
Moderate Injury 1,124
Minor Injury 2,065
Unknown Injury 26

TOTAL KILLED
634

Major Injury 1,486
Moderate Injury 5,319
Minor Injury 9,621
Unknown Injury 180

INJURY ACCIDENTS
3 75.0%

P.D.O. ACCIDENTS
1 25.0%

Moderate Injury 1
Minor Injury 2

ALCOHOL RELATED ACCIDENTS

	1984	1985	PERCENT CHANGE
ACCIDENTS	20,493	20,137	- 1.7
FATAL ACCIDENTS	625	673	+ 7.7
INJURY ACCIDENTS	13,187	13,219	+ 0.2
P.D.O. ACCIDENTS	6,681	6,245	- 6.5
NUMBER KILLED	704	767	+ 8.9
NUMBER INJURED	20,179	20,230	+ 0.3
MAJOR INJURY	1,768	1,832	+ 3.6
MODERATE INJURY	6,399	6,504	+ 1.6
MINOR INJURY	11,805	11,688	- 1.0
UNKNOWN INJURY	207	206	- 0.5
FATAL ACCIDENTS PER 100,000 LICENSED DRIVERS	8.4	8.3	- 1.2
INJURY ACCIDENTS PER 100,000 LICENSED DRIVERS	176.5	175.0	- 0.8
DEATHS PER 100,000 LICENSED DRIVERS	9.4	10.2	+ 8.5
INJURIES PER 100,000 LICENSED DRIVERS	270.1	267.8	- 0.9

YEAR	FATAL ACC'S.	INJURY ACC'S.	P.D.O. ACC'S.	TOTAL ACC'S.	TOTAL KILLED	TOTAL INJURED
1981	823	11,860	6,835	19,518	943	18,522
1982	684	12,508	6,963	20,155	800	19,499
1983	634	12,338	6,457	19,429	720	19,136
1984	625	13,187	6,681	20,493	704	20,179
1985	673	13,219	6,245	20,137	767	20,230

1985

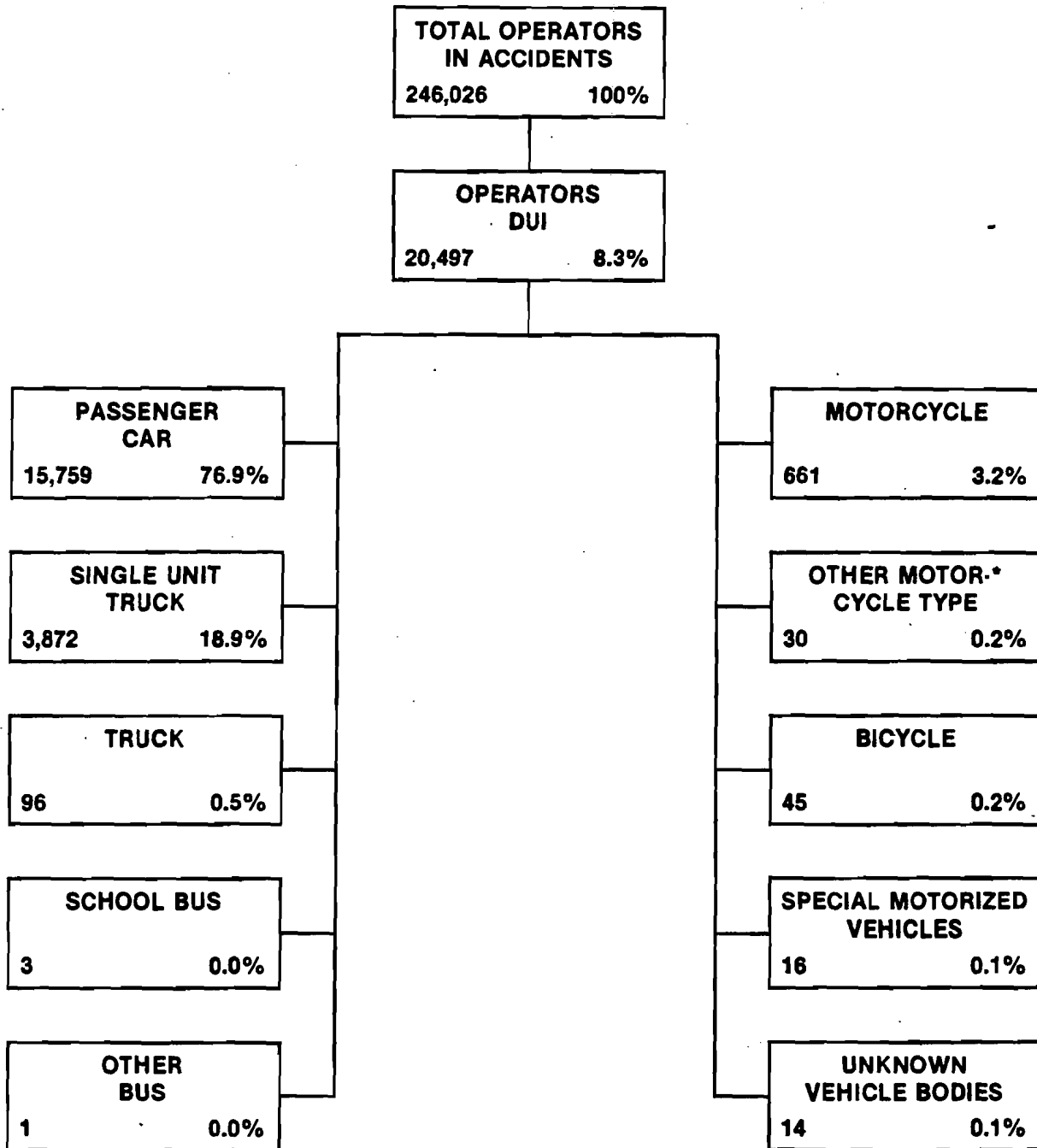

*INCLUDES MO-PEDS, MINI-BIKES, TRIKES, ETC.

IN THE 20,137 ACCIDENTS INVOLVING ALCOHOL, 20,497 OPERATORS HAD BEEN DRINKING.

IN THE 673 FATAL ACCIDENTS INVOLVING ALCOHOL, 693 OPERATORS HAD BEEN DRINKING.

1985

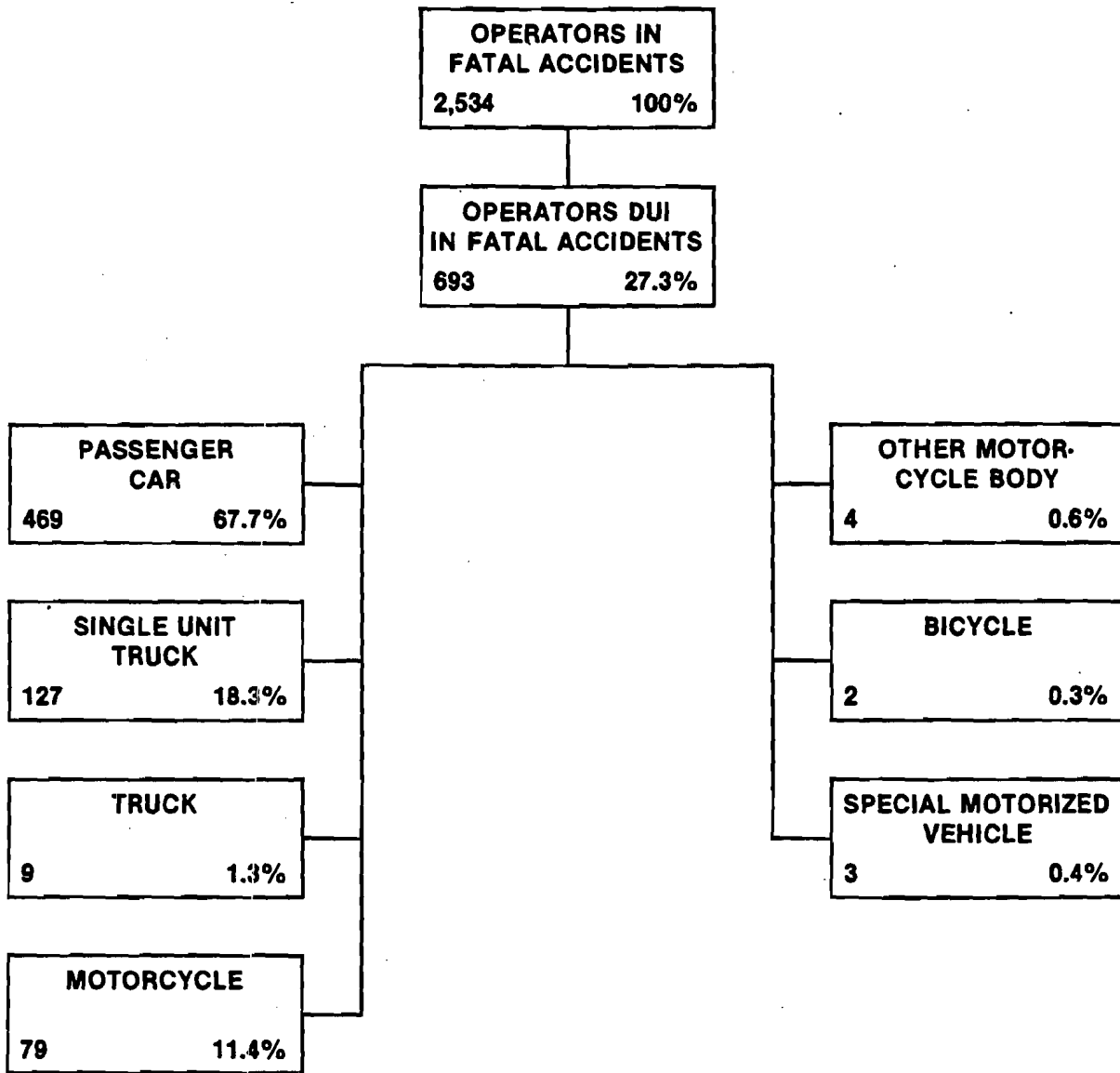

1985 PENNSYLVANIA ALCOHOL RELATED ACCIDENTS BY COUNTY

COUNTY	FATAL ACCIDENTS	INJURY ACCIDENTS	P.D.O. ACCIDENTS	TOTAL ACCIDENTS
ADAMS	9	116	57	182
ALLEGHENY	50	1178	718	1946
ARMSTRONG	4	62	40	106
BEAVER	7	170	104	281
BEDFORD	3	68	13	84
BERKS	23	375	195	593
BLAIR	5	160	75	240
BRADFORD	10	75	40	125
BUCKS	36	617	225	878
BUTLER	14	191	90	295
CAMBRIA	8	133	78	219
CAMERON	1	20	5	26
CARBON	5	84	45	134
CENTRE	7	127	47	181
CHESTER	32	565	264	861
CLARION	1	66	21	88
CLEARFIELD	6	130	63	199
CLINTON	3	45	11	59
COLUMBIA	11	82	30	123
CRAWFORD	7	148	55	210
CUMBERLAND	15	240	132	387
DAUPHIN	16	350	181	547
DELAWARE	19	584	305	908
ELK	4	48	27	79
ERIE	25	443	188	656
FAYETTE	9	210	83	302
FOREST	0	10	8	18
FRANKLIN	7	133	67	207
FULTON	1	16	10	27
GREENE	2	33	21	56
HUNTINGDON	6	46	19	71
INDIANA	6	131	49	186
JEFFERSON	1	57	24	82
JUNIATA	3	27	10	40
LACKAWANNA	7	228	116	351
LANCASTER	15	524	202	741
LAWRENCE	6	97	33	136
LEBANON	5	163	63	231
LEHIGH	17	417	209	643
LUZERNE	18	368	187	573
LYCOMING	5	175	76	256
MCKEAN	9	57	29	95
MERCER	5	129	61	195
MIFFLIN	2	53	33	88
MONROE	9	148	66	223
MONTGOMERY	35	861	448	1,344
MONTOUR	1	21	9	31
NORTHAMPTON	13	377	163	553
NORTHUMBERLAND	10	81	30	121
PERRY	5	72	31	108
PIKE	4	25	6	35
POTTER	0	30	7	37
SCHUYLKILL	15	154	64	233
SNYDER	2	31	13	46
SOMERSET	7	95	33	135
SULLIVAN	0	17	4	21
SUSQUEHANNA	3	47	17	67
TIOGA	5	76	21	102
UNION	2	34	6	42
VENANGO	8	92	51	151
WARREN	4	81	24	109
WASHINGTON	13	282	134	429
WAYNE	6	64	18	88
WESTMORELAND	27	531	255	813
WYOMING	2	52	18	72
YORK	23	517	213	753
PHILADELPHIA	34	580	305	919
TOTAL	673	13,219	6,245	20,137

1985 PENNSYLVANIA DATA BY COUNTY DUI ARRESTS AND ALCOHOL ACCIDENTS/1,000 DRIVERS

COUNTY	ALCOHOL ACCIDENTS	ALCOHOL ACCIDENTS PER 1000 DRVS	D.U.I. ARRESTS	D.U.I. ARRESTS PER 1000 DRVS	DRIVERS
ADAMS	182	3.89105	196	4.19036	46774
ALLEGHENY	1946	2.20696	4928	5.58886	881754
ARMSTRONG	106	1.86600	120	2.11245	56806
BEAVER	281	2.22835	403	3.19583	126102
BEDFORD	84	2.65143	55	1.73606	31681
BERKS	593	2.82703	444	2.11669	209761
BLAIR	240	2.76612	320	3.68817	86764
BRADFORD	125	3.01554	87	2.09881	41452
BUCKS	878	2.49881	1852	5.27084	351367
BUTLER	295	2.80682	470	4.47189	105101
CAMBRIA	219	1.92744	323	2.84276	113622
CAMERON	26	5.79323	16	3.56506	4488
CARBON	134	3.64874	81	2.20558	36725
CENTRE	181	2.77199	523	8.00968	65296
CHESTER	861	3.95753	775	3.56224	217560
CLARION	88	3.23078	110	4.03848	27238
CLEARFIELD	199	3.68164	152	2.81211	54052
CLINTON	59	2.50212	110	4.66497	23580
COLUMBIA	123	2.84163	128	2.95714	43285
CRAWFORD	210	3.62113	282	4.86266	57993
CUMBERLAND	387	2.82068	586	4.27111	137201
DAUPHIN	547	3.58597	873	5.72313	152539
DELAWARE	908	2.44676	1551	4.17943	371103
ELK	79	3.02254	72	2.75472	26137
ERIE	656	3.64107	523	2.90286	180167
FAYETTE	302	2.86775	208	1.97514	105309
FOREST	18	4.35835	30	7.26392	4130
FRANKLIN	207	2.79839	407	5.50216	73971
FULTON	27	3.08677	39	4.45867	8747
GREENE	56	2.19144	85	3.32629	25554
HUNTINGDON	71	2.53852	60	2.14523	27969
INDIANA	186	3.15618	262	4.44580	58982
JEFFERSON	82	2.45943	97	2.90933	33341
JUNIATA	40	3.10487	52	4.03633	12883
LACKAWANNA	351	2.53106	320	2.30752	138677
LANCASTER	741	3.02372	717	2.92579	245062
LAWRENCE	136	1.87470	244	3.36343	72545
LEBANON	231	3.09922	314	4.21279	74535
LEHIGH	643	3.67803	572	3.27190	174822
LUZERNE	573	2.71996	439	2.08388	210665
LYCOMING	256	3.28521	520	6.67308	77925
MCKEAN	95	2.87922	70	2.12153	32995
MERCER	195	2.32392	360	4.29031	83910
MIFFLIN	88	3.14218	176	6.28437	28006
MONROE	223	4.05116	155	2.81583	55046
MONTGOMERY	1344	2.74259	1936	3.95063	490048
MONTOUR	31	2.68375	50	4.32863	11551
NORTHAMPTON	553	3.20383	617	3.57462	172606
NORTHUMBERLAND	121	1.90147	164	2.57720	63635
PERRY	108	4.06321	115	4.32656	26580
PIKE	35	2.56843	0	0.51369	13627
POTTER	37	2.99232	25	2.02184	12365
SCHUYLKILL	233	2.29604	235	2.31575	101479
SNYDER	46	2.06797	46	2.06797	22244
SOMERSET	135	2.43449	226	4.07552	55453
SULLIVAN	21	4.82426	5	1.14863	4353
SUSQUEHANNA	67	2.64990	28	1.10742	25284
TIOGA	102	4.02557	96	3.78878	25338
UNION	42	1.94905	39	1.80983	21549
VENANGO	151	3.75678	161	4.00557	40194
WARREN	109	3.48867	163	5.21700	31244
WASHINGTON	429	2.98273	555	3.85878	143828
WAYNE	88	2.84790	31	1.00324	30900
WESTMORELAND	813	3.18887	888	3.48305	254949
WYOMING	72	7.03056	42	4.10116	10241
YORK	753	3.45456	937	4.29870	217973
PHILADELPHIA	919	1.24706	3623	4.91632	736933

1985 ALCOHOL ACCIDENT RATES PER 1,000 DRIVERS PENNSYLVANIA STATE HIGHWAY ENGINEERING DISTRICTS

1 ENGINEERING DISTRICT
★ DISTRICT OFFICE

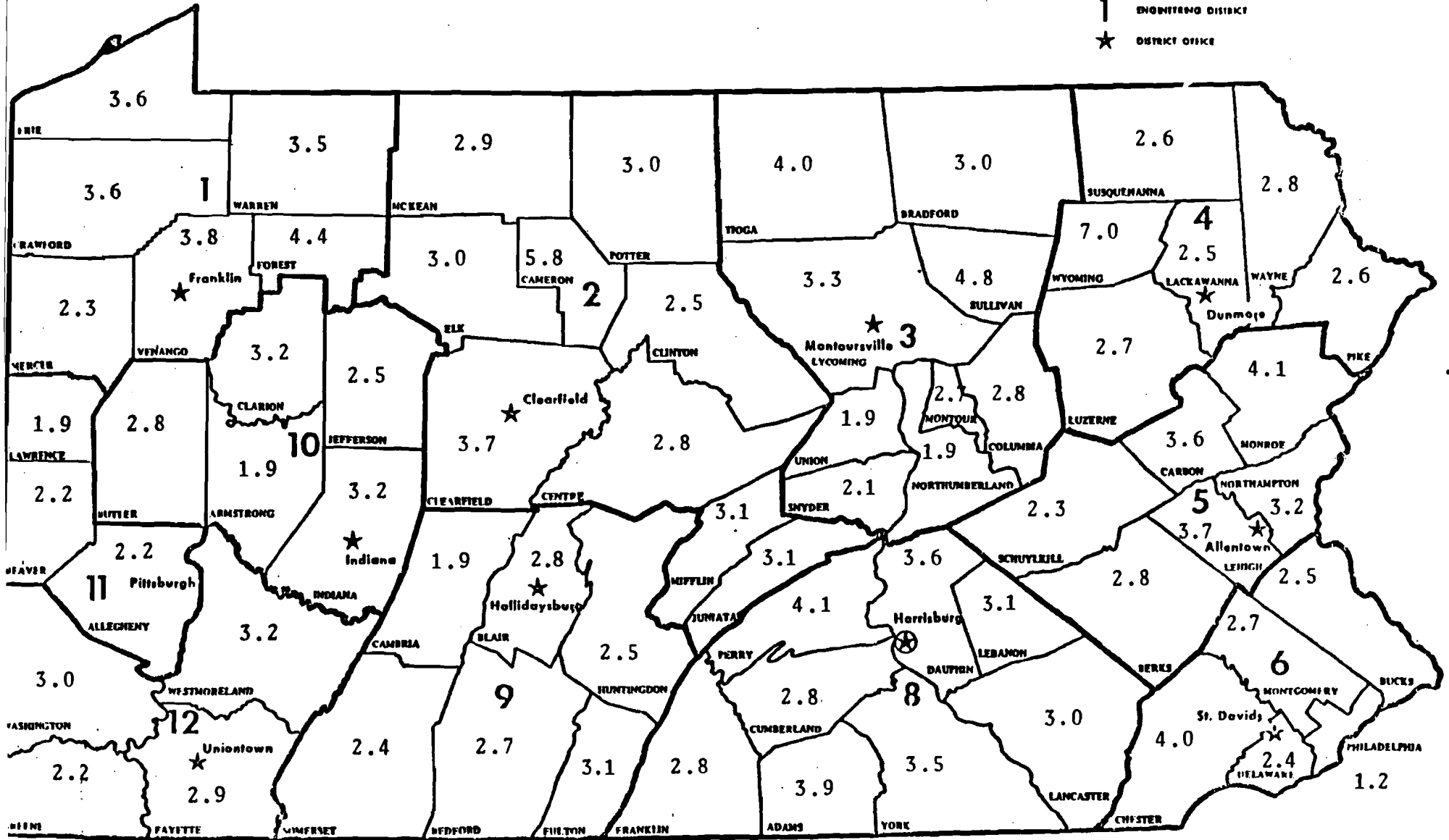

1985 D.U.I. ARREST RATES PER 1,000 DRIVERS PENNSYLVANIA STATE HIGHWAY ENGINEERING DISTRICTS

1 ENGINEERING DISTRICT
★ DISTRICT OFFICE

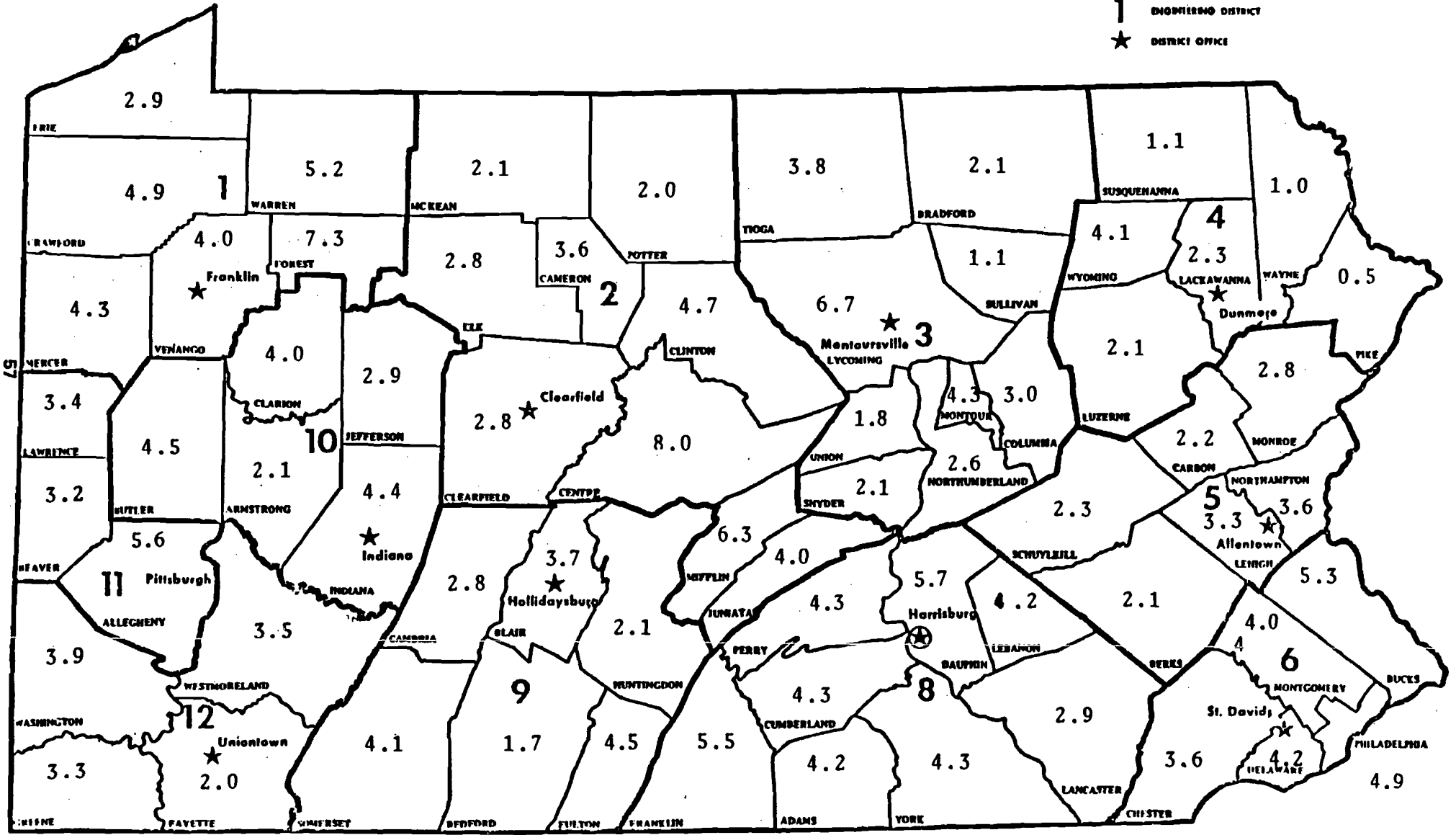

1985 ALCOHOL-RELATED ACCIDENTS PENNSYLVANIA STATE HIGHWAY ENGINEERING DISTRICTS

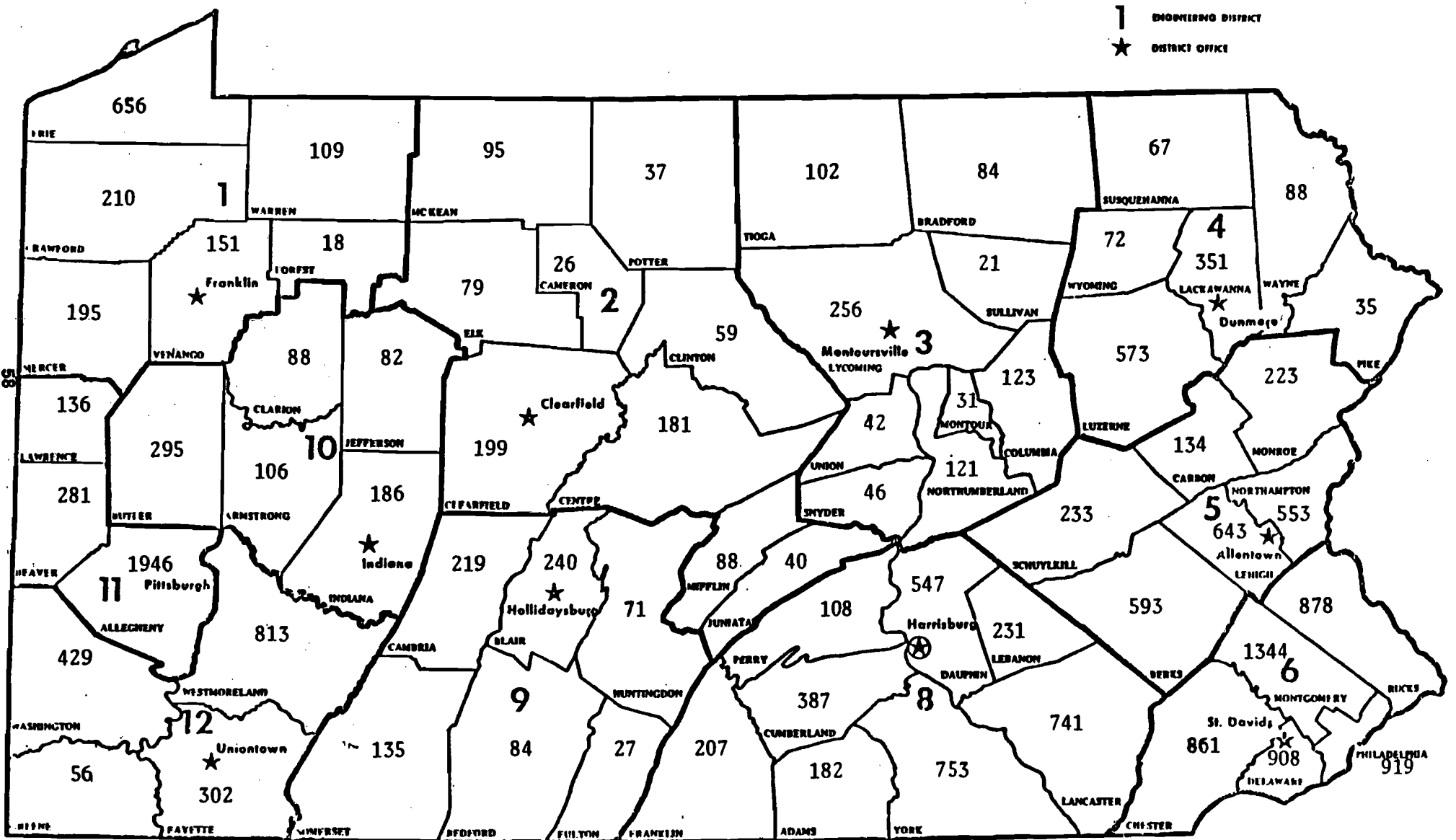

1985 D.U.I. OFFENSES CHARGED

Age	Male	Female	Total	%
◀ 16	25	5	30	0.1
16-20	2,783	309	3,092	10.3
21-24	5,385	674	6,059	20.2
25-29	5,680	691	6,371	21.3
30-34	3,936	425	4,361	14.5
35-39	2,952	275	3,227	10.8
40-44	1,981	238	2,219	7.4
45-49	1,323	131	1,454	4.8
50-54	1,060	88	1,148	3.8
55-59	846	72	918	3.1
60-64	563	24	587	2.0
65 +	488	27	515	1.7
TOTAL	27,022	2,959	29,981	100
%	90.1	9.9%	100	

**ALCOHOL RELATED ACCIDENTS
BY MONTH
1985**

MONTH	TOTAL ACCIDENTS		FATAL ACCIDENTS		TOTAL KILLED	
	SUM	ME.A.D.*	SUM	ME.A.D.*	SUM	ME.A.D.*
January	1403	45.2581	39	1.25806	46	1.48387
February	1249	44.6071	30	1.07143	30	1.07143
March	1808	58.3226	59	1.90323	64	2.06452
April	1616	53.8667	58	1.93333	63	2.1
May	1701	54.871	69	2.22581	76	2.45161
June	1838	61.2267	60	2	67	2.23333
July	1594	51.4194	50	1.6129	56	1.80645
August	1772	57.1613	55	1.77419	65	2.09677
September	1744	58.1333	73	2.43333	84	2.8
October	1707	55.0645	62	2	70	2.25806
November	1834	61.1333	61	2.03333	81	2.7
December	1871	60.3548	57	1.83871	65	2.09677

*Mean Accidents Per Day

1985 ALCOHOL RELATED FATAL ACCIDENTS
TIME OF DAY by DAY OF WEEK

Time	Day	Sunday	Monday	Tuesday	Wednesday	Thursday	Friday	Saturday	Unknown	Total
6:00-6:59 am		2	1	1	0	0	3	5	0	12
7:00-7:59 am		3	1	0	0	0	0	0	0	4
8:00-8:59 am		1	0	0	0	0	0	1	0	2
9:00-9:59 am		0	0	0	0	0	0	1	0	1
10:00-10:59 am		0	0	0	0	0	0	1	0	1
11:00-11:59 am		1	0	0	1	0	0	3	0	5
12 noon-12:59 pm		1	0	0	3	0	2	2	0	8
1:00-1:59 pm		1	1	2	1	0	2	4	0	11
2:00-2:59 pm		0	1	1	0	0	4	1	0	7
3:00-3:59 pm		4	1	3	5	0	0	4	0	17
4:00-4:59 pm		5	0	2	3	1	1	2	0	14
5:00-5:59 pm		3	4	2	3	3	4	6	0	25
6:00-6:59 pm		3	4	2	2	4	3	7	0	25
7:00-7:59 pm		4	3	2	4	7	4	10	0	34
8:00-8:59 pm		6	4	3	4	1	17	3	0	38
9:00-9:59 pm		4	6	4	9	5	6	8	0	42
10:00-10:59 pm		4	7	6	6	4	9	6	0	42
11:00-11:59 pm		6	7	5	3	7	12	21	0	61
12 mdn-12:50 am		13	9	9	2	6	10	12	0	61
1:00-1:59 am		16	4	5	7	8	7	26	0	73
2:00-2:59 am		17	3	5	8	9	14	27	0	83
3:00-3:59 am		12	3	7	5	3	8	18	0	56
4:00-4:59 am		14	1	2	0	3	2	12	0	34
5:00-5:59 am		3	1	1	2	2	2	5	0	16
Unknown		0	0	1	0	0	0	0	0	1
TOTAL		123	61	63	68	63	110	185	0	673

1985 ALCOHOL RELATED ACCIDENTS

TIME OF DAY vs DAY OF WEEK

Time	Day	Sunday	Monday	Tuesday	Wednesday	Thursday	Friday	Saturday	Unknown	Total
6:00-6:59 am		66	7	19	12	19	19	83	0	225
7:00-7:59 am		42	9	15	16	8	16	47	0	153
8:00-8:59 am		24	4	7	11	13	8	22	0	89
9:00-9:59 am		14	0	12	5	11	9	15	0	66
10:00-10:59 am		9	6	6	5	6	8	23	0	63
11:00-11:59 am		13	3	8	9	9	17	24	0	83
12 noon-12:59 pm		17	8	14	21	21	25	34	0	140
1:00-1:59 pm		22	19	22	22	20	22	52	0	179
2:00-2:59 pm		37	22	23	28	33	46	46	0	235
3:00-3:59 pm		45	42	57	45	59	91	92	0	431
4:00-4:59 pm		97	59	70	56	50	91	127	0	550
5:00-5:59 pm		105	77	64	71	85	130	149	0	661
6:00-6:59 pm		112	85	118	79	113	149	205	0	861
7:00-7:59 pm		141	124	91	92	121	210	217	0	996
8:00-8:59 pm		160	115	124	138	148	237	228	0	1,150
9:00-9:59 pm		168	161	128	179	182	290	301	0	1,409
10:00-10:59 pm		168	156	166	185	180	407	345	0	1,607
11:00-11:59 pm		204	194	198	191	267	493	437	0	1,984
12 mdn-12:50 am		446	175	166	161	216	258	541	0	1,963
1:00-1:59 am		474	131	153	190	223	276	643	0	2,090
2:00-2:59 am		595	151	169	177	230	320	815	0	2,457
3:00-3:59 am		387	68	102	83	119	161	482	0	1,402
4:00-4:59 am		253	37	51	43	65	79	98	0	826
5:00-5:59 am		131	12	28	25	44	37	152	0	429
Unknown		14	3	7	4	9	10	21	0	68
TOTAL		3,744	1,668	1,818	1,848	2,251	3,409	5,399	0	20,137

1985 D.U.I. Offenses Charged

Distribution by Age and Sex

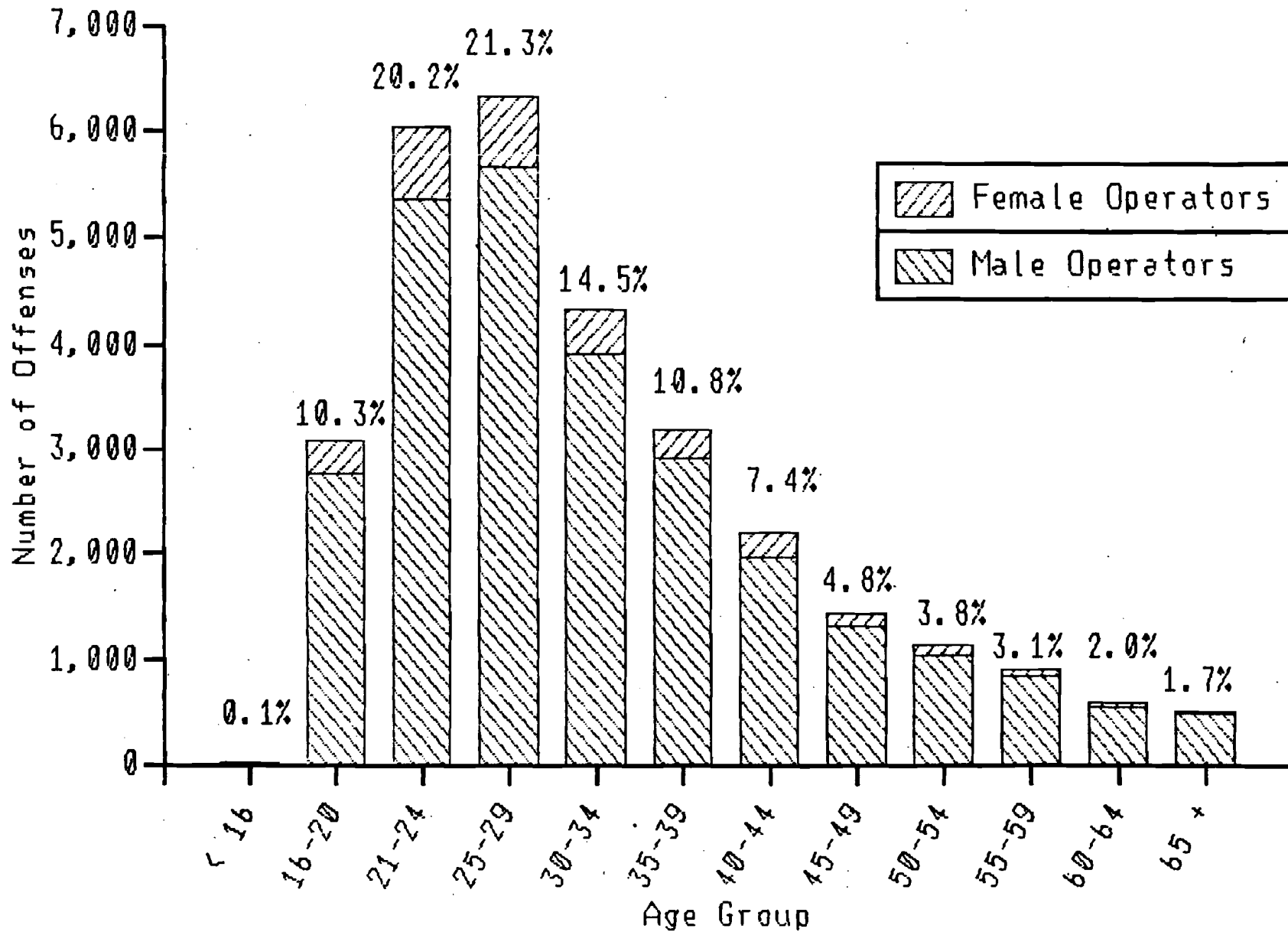

Victims of Alcohol Related Fatal Accidents Distribution by Age

1985

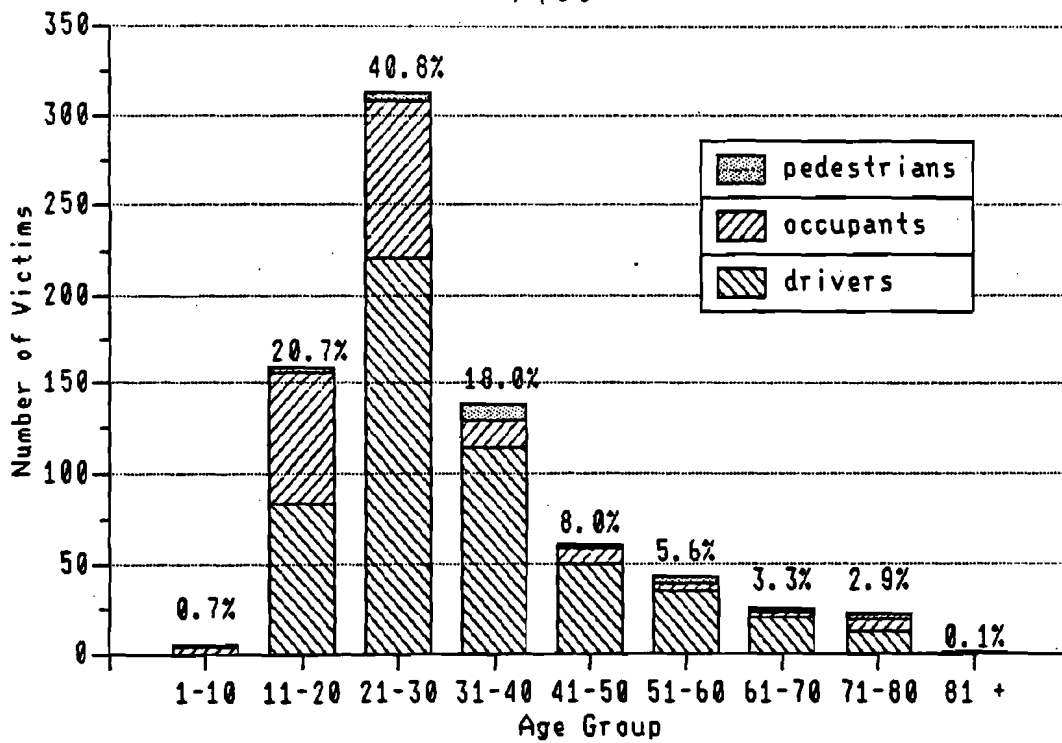

Fatal Accidents by Day of Week 1985

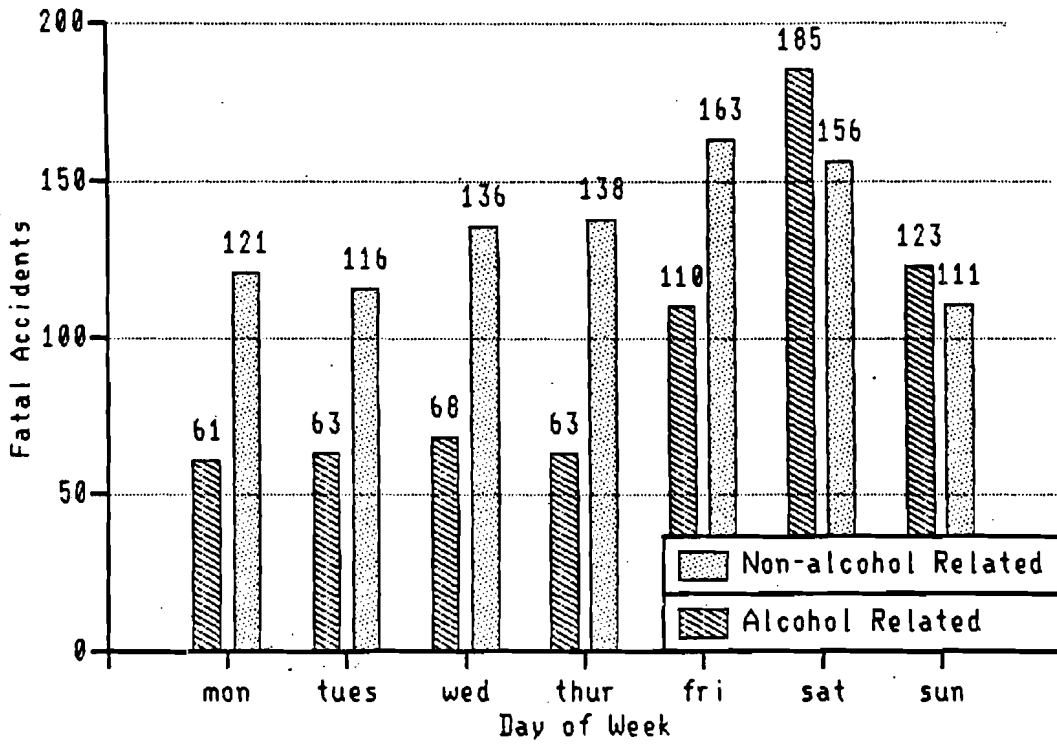

Fatal Accident Causation Factors 1985

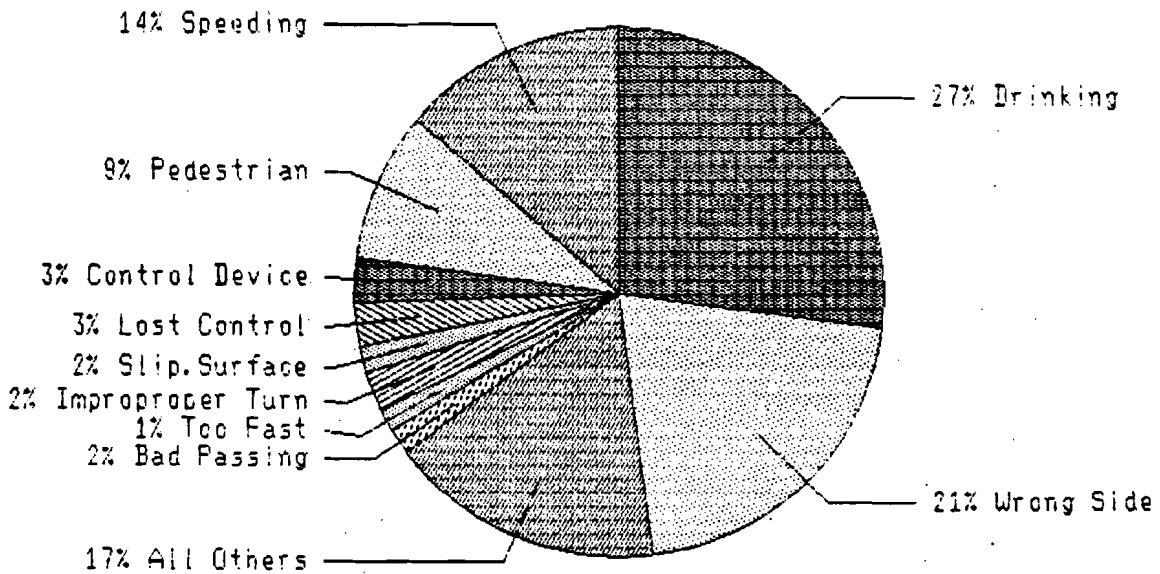

Fatal Accidents by Month 1985

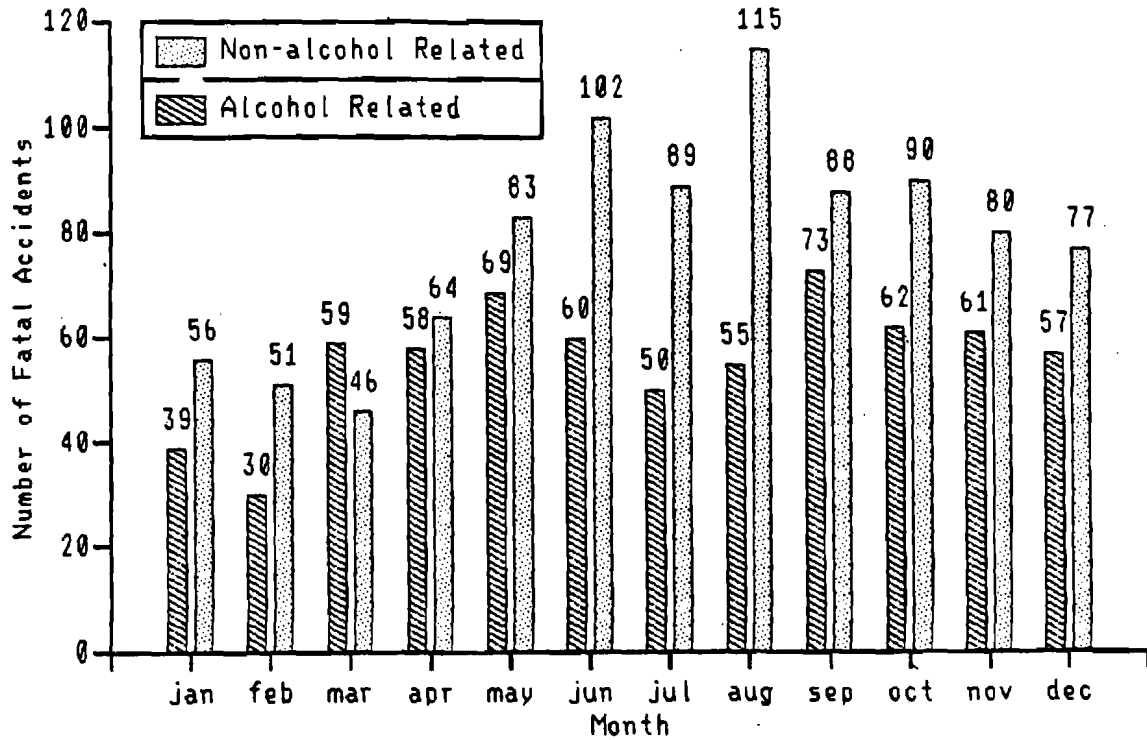

1985 Fatal Accidents 10 pm - 4 am

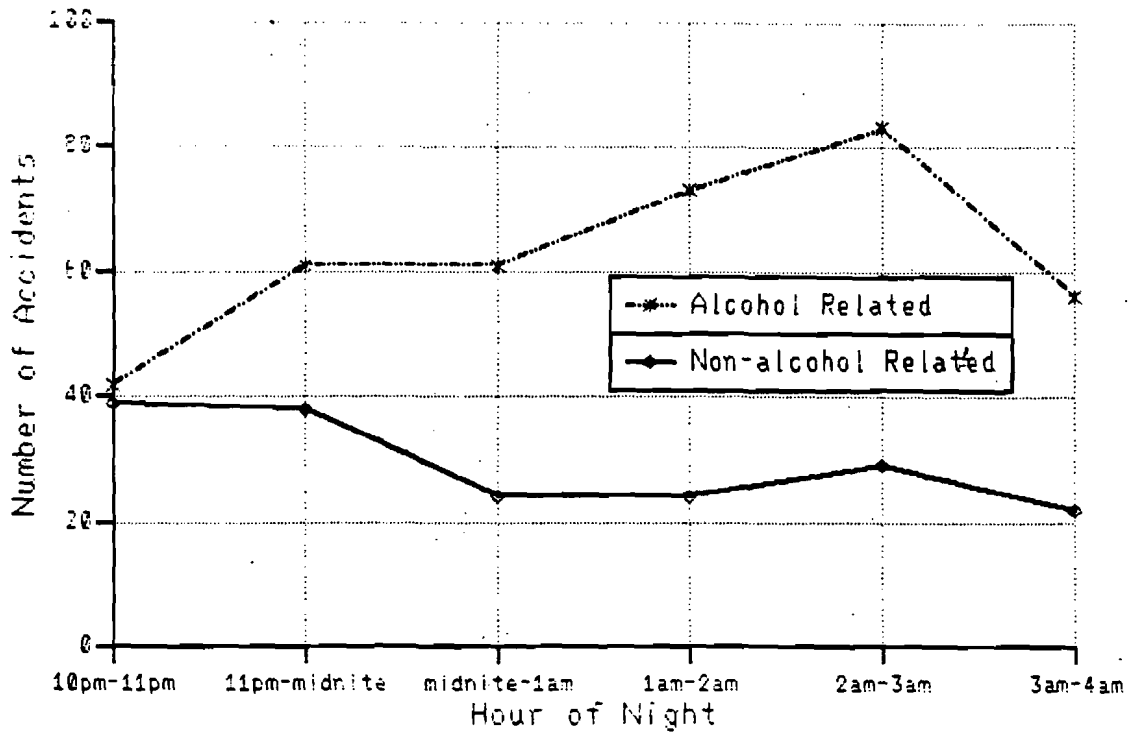

Age and Sex of Operator Driving Under the Influence

1985

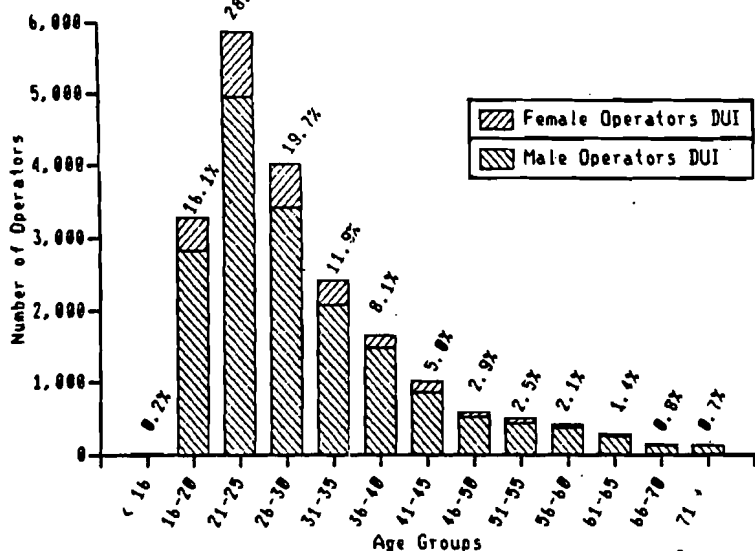

Age and Sex of Passenger Car Operators Driving Under the Influence

1985

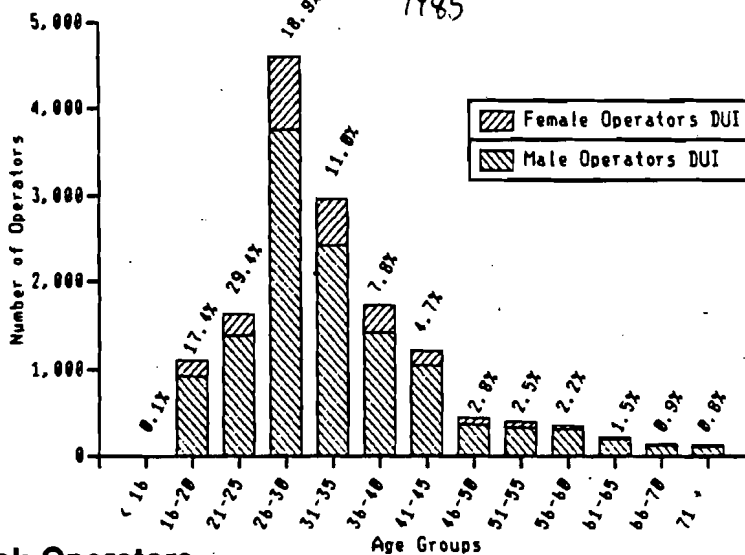

Age and Sex of Single Unit Truck Operators Driving Under the Influence

1985

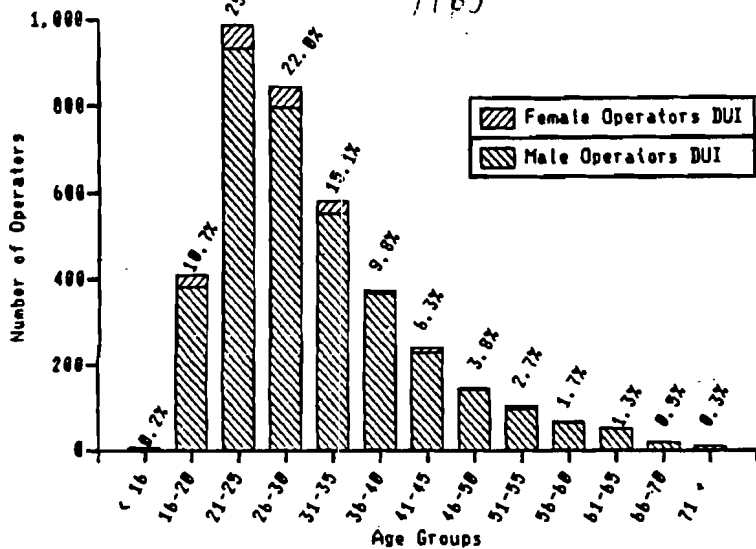

Age and Sex of Truck Operators Driving Under the Influence

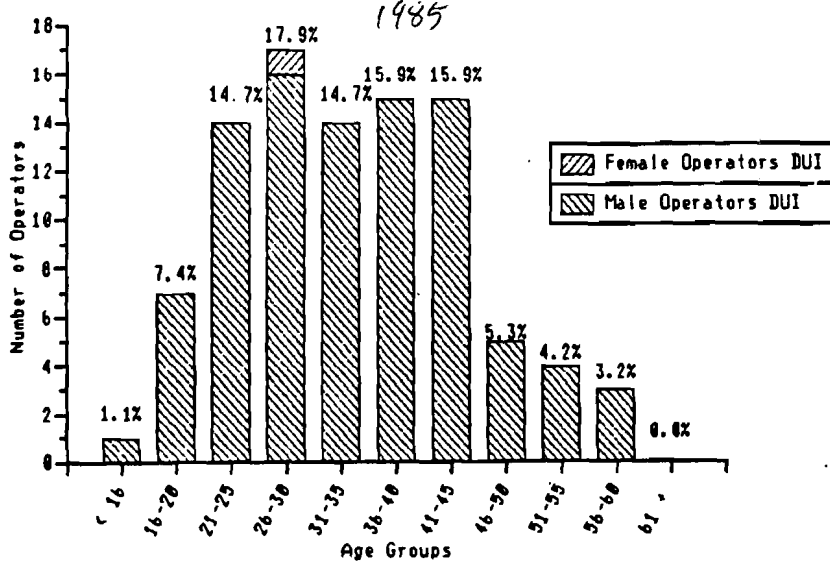

Age and Sex of Motorcycle Operators Driving Under the Influence

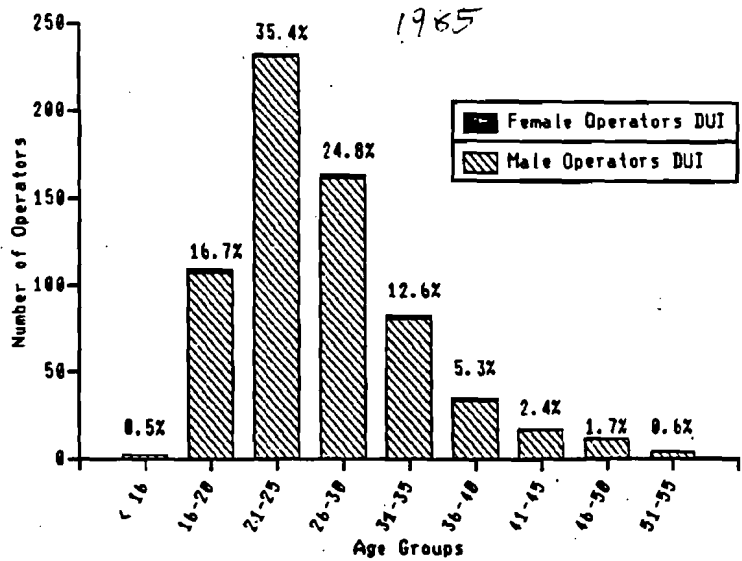

Age and Sex of All Motorcycle Type Operators Driving Under the Influence

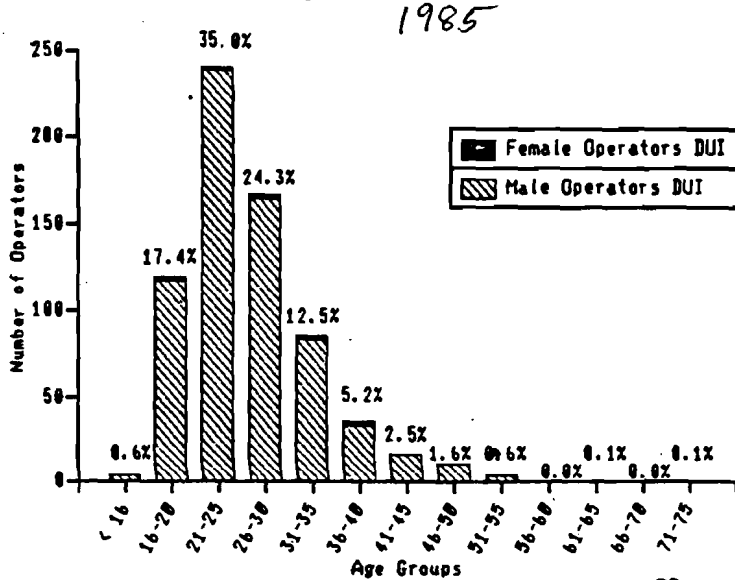



PEDESTRIAN RELATED ACCIDENT STATISTICS

1985

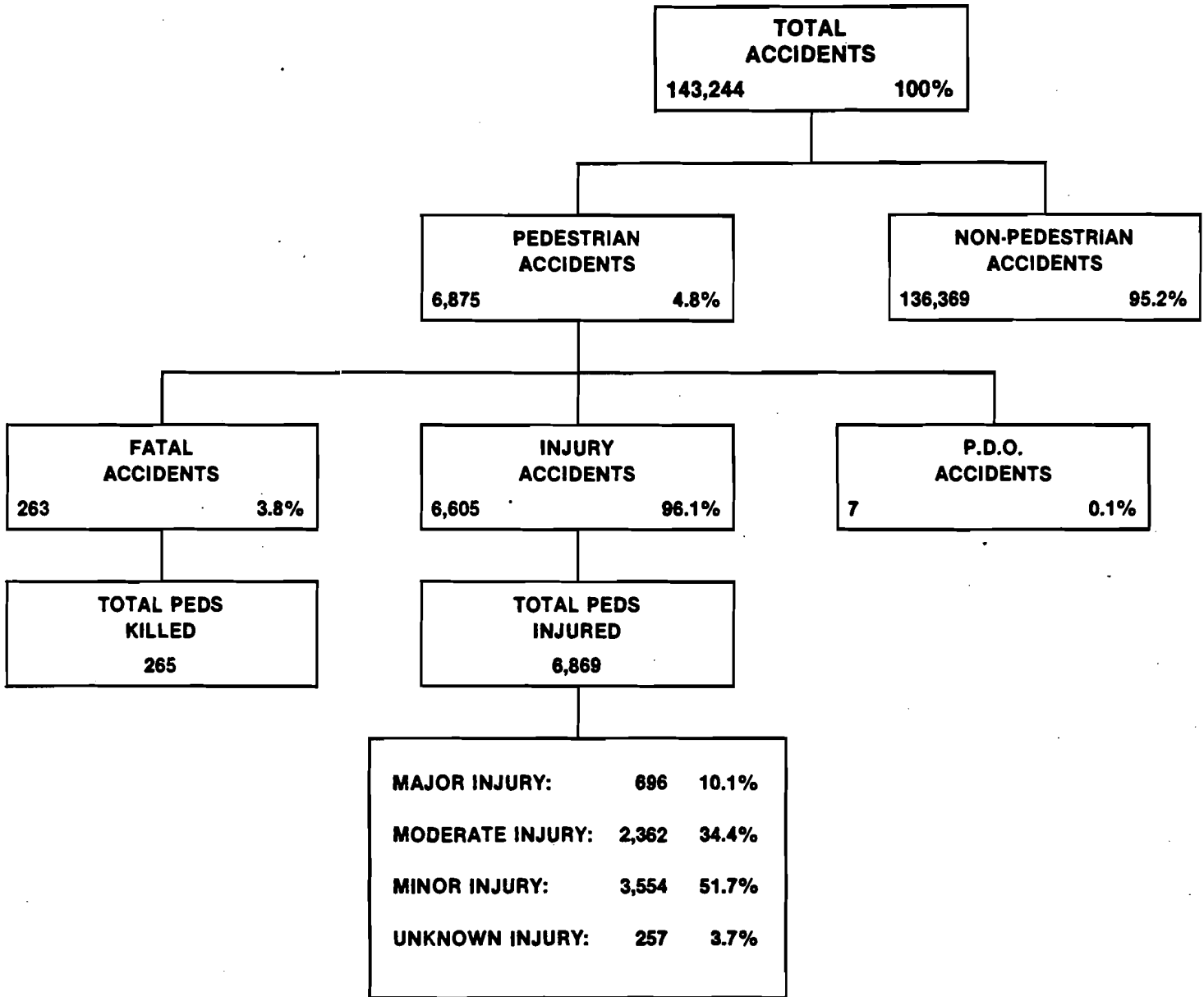

**1985 PENNSYLVANIA DATA BY COUNTY
PEDESTRIAN FATALITIES & ACCIDENTS/100,000 POPULATION**

COUNTY	PEDESTRIANS KILLED	PEDESTRIANS KILLED PER 100,000	PEDESTRIAN ACCIDENTS	PEDESTRIAN ACCIDENTS PER 100,000	POPULATION
ADAMS	3	4.27606	25	35.6339	70158
ALLEGHENY	30	2.08606	666	46.3105	1438120
ARMSTRONG	0	0	12	15.3571	78140
BEAVER	2	0.98762	54	26.6656	202508
BEDFORD	0	0	8	16.7602	47732
BERKS	8	2.54191	175	55.6043	314724
BLAIR	2	1.47215	40	29.4429	135856
BRADFORD	1	1.56250	13	20.3125	64000
BUCKS	13	2.62337	177	35.7182	495545
BUTLER	2	1.33522	40	26.7044	149788
CAMBRIA	3	1.67393	43	23.9930	179219
CAMERON	0	0	2	29.4334	6795
CARBON	0	0	13	24.0785	53990
CENTRE	3	2.63720	39	34.2836	113757
CHESTER	5	1.53442	114	34.9848	325856
CLARION	1	2.31997	8	18.5598	43104
CLEARFIELD	0	0	32	38.5928	82917
CLINTON	3	7.73654	13	33.5250	38777
COLUMBIA	1	1.61309	23	37.1010	61993
CRAWFORD	1	1.11682	28	31.2709	89540
CUMBERLAND	8	4.38909	64	35.1127	182270
DAUPHIN	3	1.28065	105	44.8228	234256
DELAWARE	8	1.45121	329	59.6810	551264
ELK	0	0	7	18.4143	38014
ERIE	8	2.84538	172	61.1756	281158
FAYETTE	3	1.89720	41	25.9284	158128
FOREST	0	0	1	19.9084	5023
FRANKLIN	5	4.33666	40	34.6933	115296
FULTON	0	0	0	0	13256
GREENE	0	0	3	7.3438	40851
HUNTINGDON	1	2.34841	15	35.2262	42582
INDIANA	0	0	19	20.4528	92897
JEFFERSON	0	0	19	39.1850	48488
JUNIATA	1	5.14933	4	20.5973	19420
LACKAWANNA	3	1.33028	111	49.2205	225516
LANCASTER	10	2.68852	153	41.1343	371952
LAWRENCE	3	2.82167	36	33.8600	106320
LEBANON	2	1.80483	41	36.9989	110814
LEHIGH	4	1.45467	138	50.1860	274977
LUZERNE	12	3.53125	172	50.6146	339823
LYCOMING	1	0.85223	38	32.3848	117339
MCKEAN	0	0	18	36.3798	49478
MERCER	2	1.56881	24	18.8257	127485
MIFFLIN	1	2.15336	7	15.0735	46439
MONROE	1	1.36685	24	32.8044	73161
MONTGOMERY	16	2.45633	256	39.3012	651379
MONTOUR	1	5.94283	6	35.6570	16827
NORTHAMPTON	3	1.31399	94	41.1717	228312
NORTHUMBERLAND	4	3.98561	26	25.9065	100361
PERRY	0	0	11	30.0941	36552
PIKE	0	0	5	25.5663	19557
POTTER	0	0	7	39.235	17842
SCHUYLKILL	5	3.1491	58	36.529	158777
SNYDER	1	2.9192	11	32.111	34256
SOMERSET	0	0	19	23.280	81614
SULLIVAN	1	15.7828	1	15.783	6336
SUSQUEHANNA	0	0	3	7.888	38032
TIOGA	2	4.8800	10	24.400	40984
UNION	3	8.9558	10	29.853	33498
VENANGO	0	0	24	36.924	64998
WARREN	3	6.2634	20	41.756	47897
WASHINGTON	3	1.3798	55	25.297	217419
WAYNE	0	0	14	38.417	36442
WESTMORELAND	10	2.5545	102	26.056	391466
WYOMING	0	0	12	44.867	26746
YORK	3	0.9461	138	43.521	317089
PHILADELPHIA	44	2.6420	2599	156.060	1665382

1985 PENNSYLVANIA PEDESTRIAN FATALITY RATES PER 100,000 POPULATION PENNSYLVANIA STATE HIGHWAY ENGINEERING DISTRICTS

1 ENGINEERING DISTRICT
★ DISTRICT OFFICE

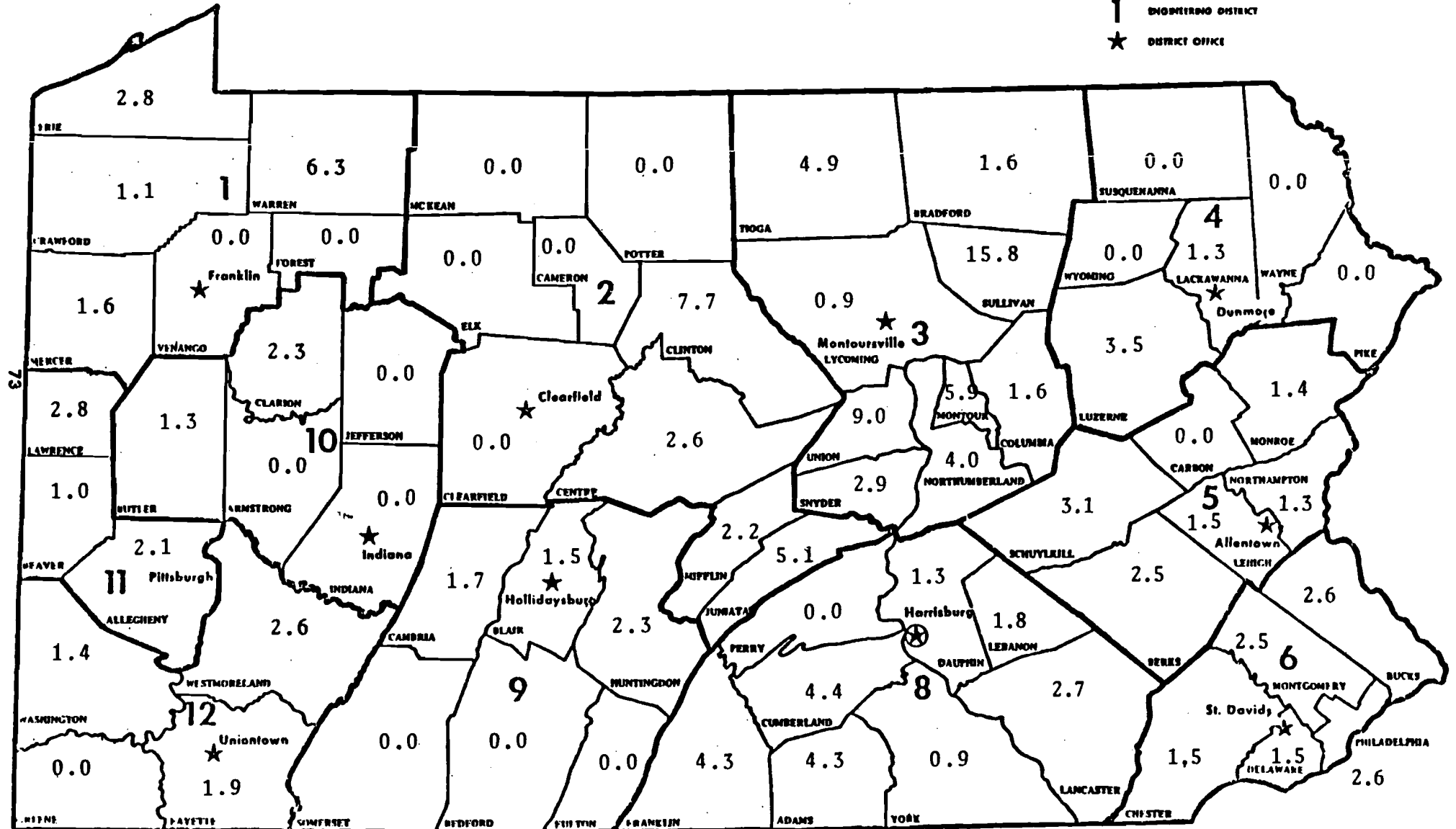

PEDESTRIAN ACTION vs AGE vs SEVERITY OF ACCIDENT — 1985

ACTION	0-4		5-9		10-14		15-19		20-34		35-44		45-54		55-64		65-74		75+		Unknown	
	Fat	Inj	Fat	Inj	Fat	Inj	Fat	Inj	Fat	Inj	Fat	Inj	Fat	Inj	Fat	Inj	Fat	Inj	Fat	Inj	Fat	Inj
1	1	171	0	388	0	117	0	48	0	88	0	26	0	16	0	13	1	12	1	9	0	20
2	0	7	2	46	1	76	0	52	2	117	0	45	2	38	3	29	2	45	8	28	0	18
3	0	7	0	33	0	32	0	57	1	134	0	54	0	38	0	44	3	54	1	35	0	23
4	0	17	0	56	0	44	0	44	0	100	0	24	0	23	0	32	2	37	0	41	0	18
5	9	187	16	531	5	412	9	276	15	552	7	163	6	124	15	145	18	137	32	107	0	105
6	0	0	0	5	0	5	0	2	0	0	0	0	0	0	0	0	0	0	0	0	0	0
7	0	3	0	4	0	20	0	16	0	40	0	13	0	6	0	6	0	5	0	7	0	1
8	0	1	0	1	0	4	1	4	0	8	1	0	2	1	0	2	1	0	0	0	0	2
9	0	5	0	12	0	17	0	24	1	68	2	25	1	11	0	14	0	8	1	3	0	16
10	1	22	1	51	0	22	0	7	0	3	0	0	0	0	0	0	0	0	0	0	0	6
11	0	0	0	3	0	1	0	12	1	34	0	15	0	6	0	6	1	1	0	2	0	7
12	0	7	1	28	0	33	0	8	1	3	0	0	0	0	0	0	0	0	0	1	0	3
13	0	8	1	11	1	21	2	57	14	172	11	63	3	35	3	20	2	14	2	7	0	21
14	0	0	0	2	2	10	0	23	4	31	1	13	1	7	1	8	0	2	1	4	0	1
15	0	0	0	5	0	28	3	53	4	82	4	29	0	11	1	10	5	3	0	4	1	11
16	0	17	0	41	1	35	0	50	1	72	1	27	0	24	2	18	1	8	2	12	0	18
17	0	0	1	4	0	3	0	9	3	14	1	2	3	3	3	2	0	4	1	2	0	3
TOTAL	11	452	22	1221	10	880	15	742	47	1518	28	499	18	343	28	349	36	330	49	262	1	273

- 1 - COMING FROM BEHIND PARKED VEHICLE
- 3 - CROSSING WITH SIGNAL
- 5 - CROSSING, NO SIGNAL, OR CROSSWALKS
- 9 - GETTING ON/OFF OTHER VEHICLE
- 9 - ON SIDEWALK
- 11 - PUSHING/WORKING ON VEHICLE ON/NEAR ROADWAY
- 13 - STANDING, WORKING, ON/NEAR ROADWAY
- 15 - WALKING ON ROADWAY/BERM - WITH TRAFFIC
- 17 - UNKNOWN

- 2 - CROSSING AGAINST SIGNAL
- 4 - CROSSING, NO SIGNAL, MARKED CROSSWALKS
- 6 - GETTING ON/OFF SCHOOL BUS
- 8 - LYING ON OR NEAR ROADWAY
- 10 - PLAYING ON OR NEAR ROADWAY
- 12 - SKATEBOARDING, SLEDDING
- 14 - WALKING ON ROADWAY/BERM - AGAINST TRAFFIC
- 16 - OTHER

7A

Pedestrians Suffering Major Injuries Distribution by Age and Sex* 1985 Accidents

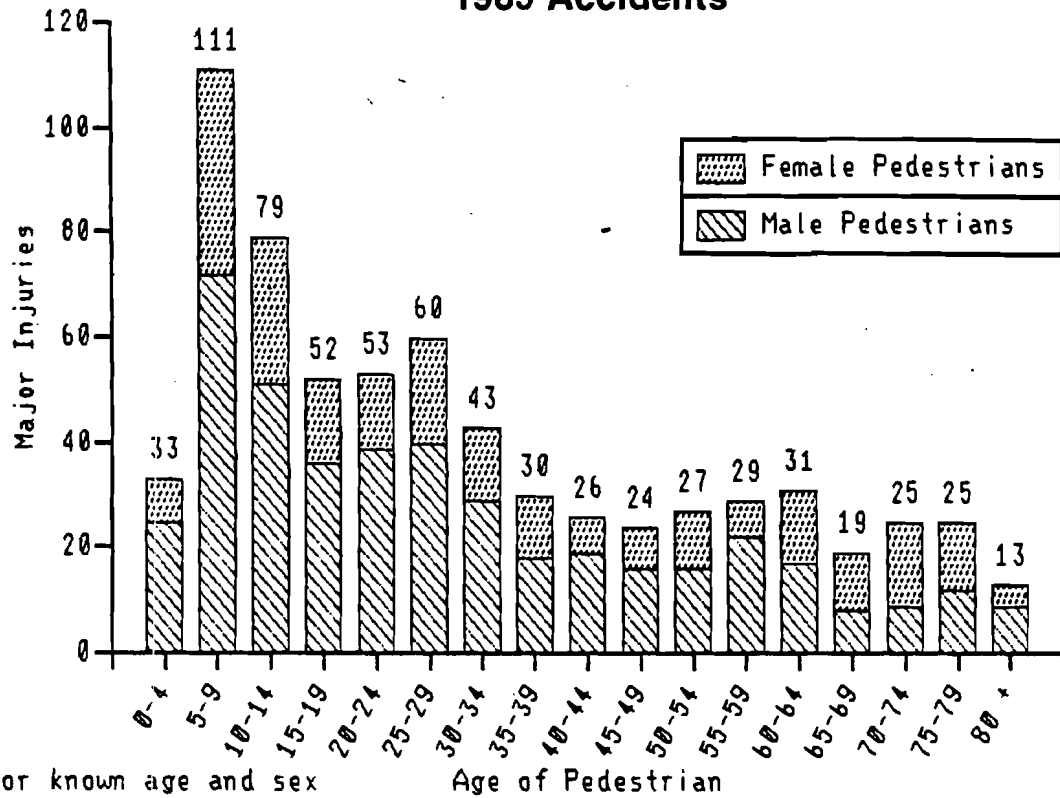

1985 Pedestrians Deaths Distribution by Age and Sex

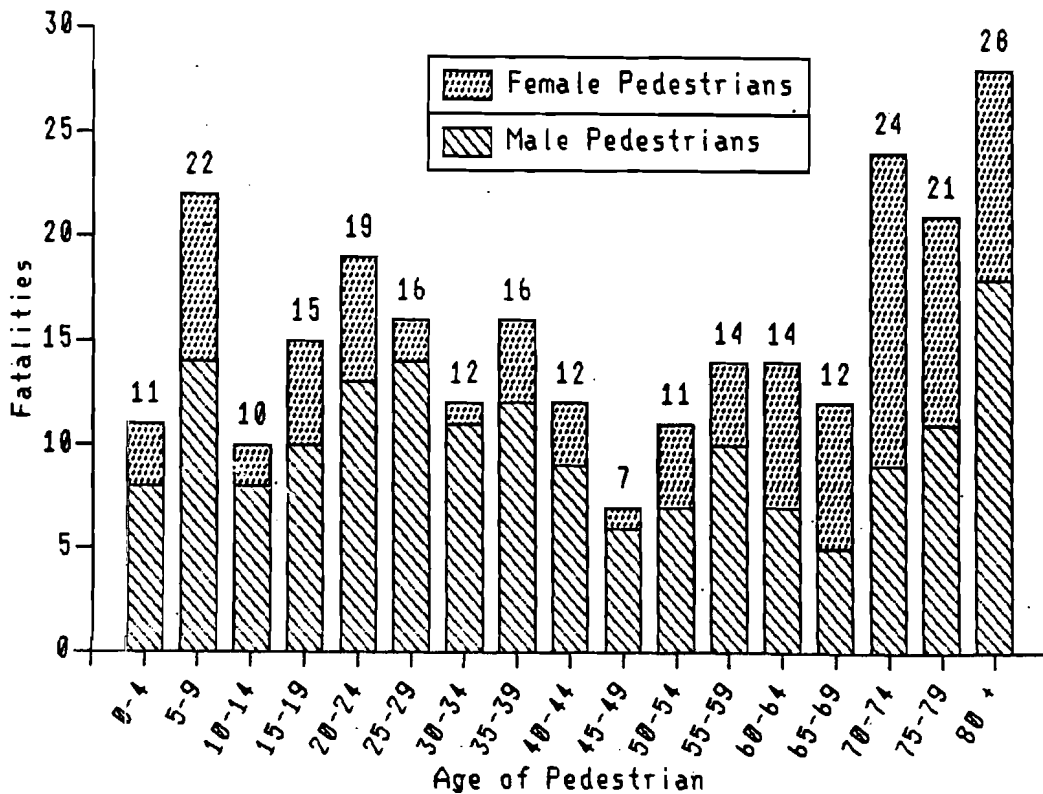

Pedestrians Suffering Moderate Injuries Distribution by Age and Sex* 1985 Accidents

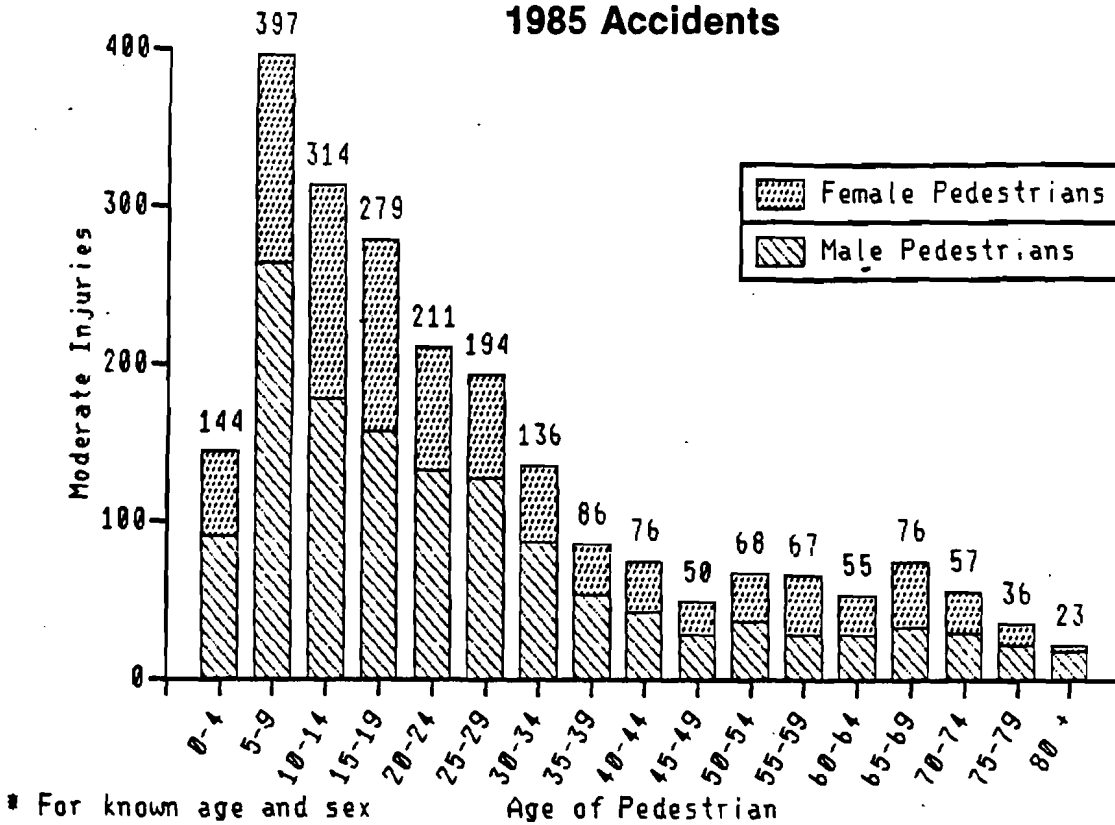

Pedestrians Suffering Minor Injuries Distribution by Age and Sex* 1985 Accidents

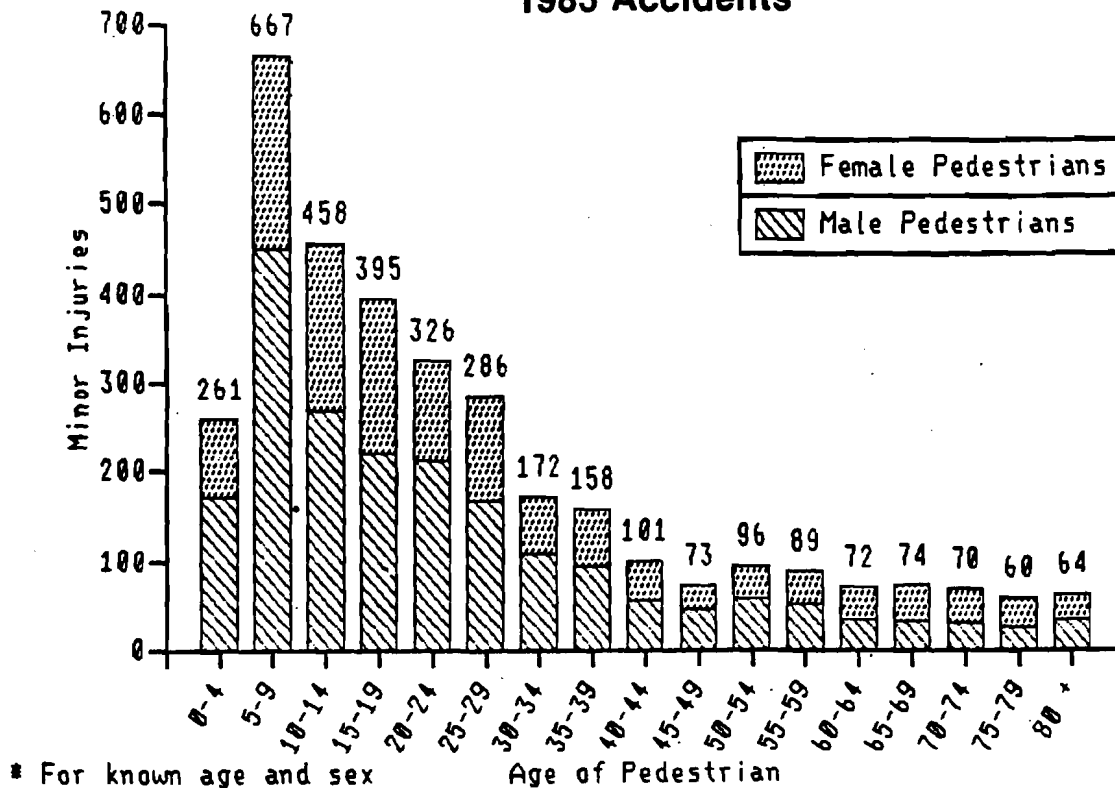

Type of Vehicle to Hit Pedestrian 1985 Accidents

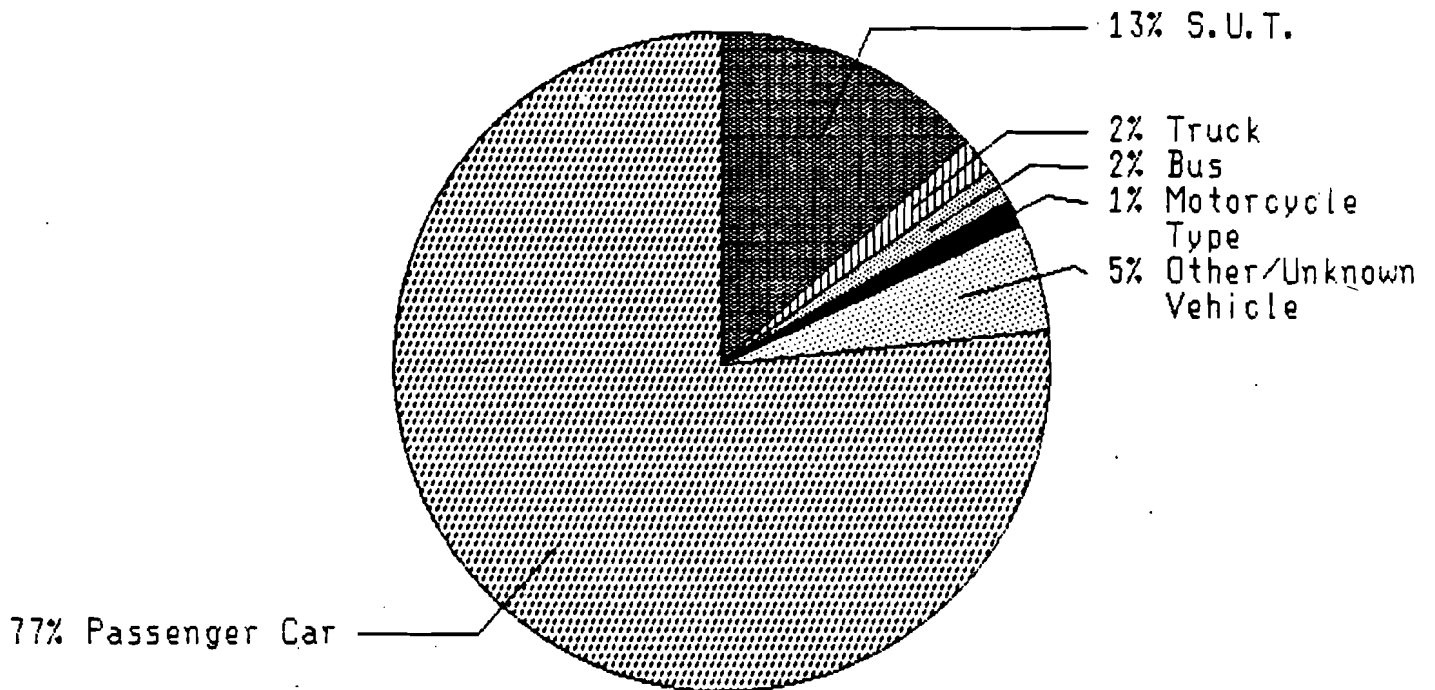

Pedestrians Killed 1978 - 1985

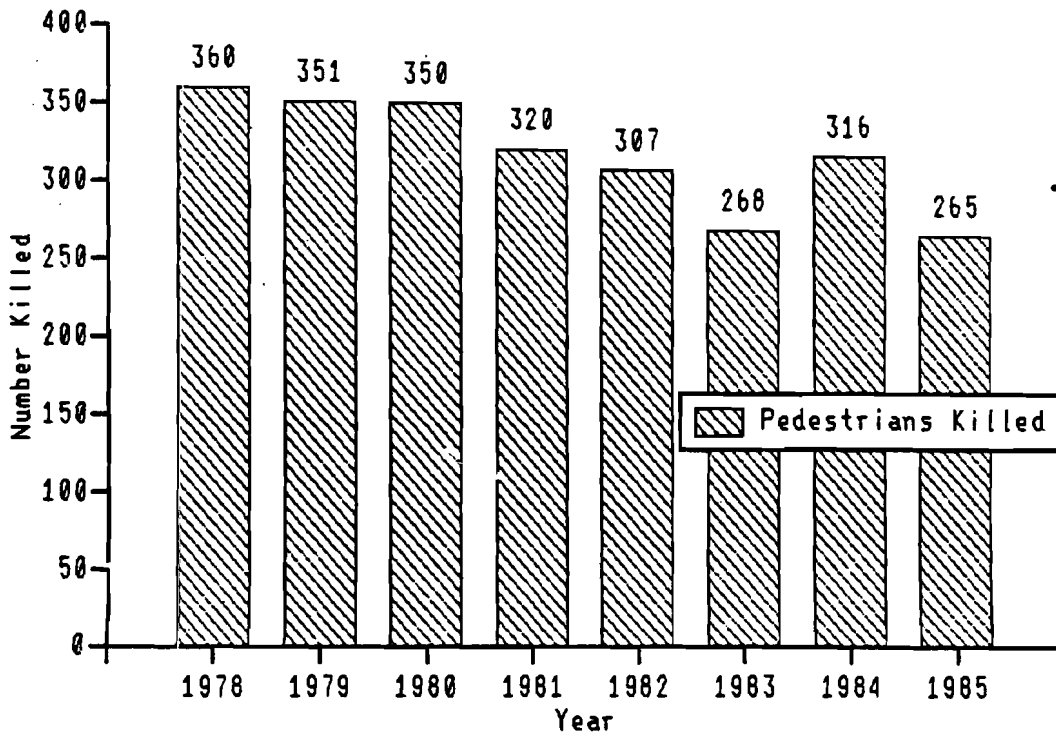

Type of Vehicle to Kill Pedestrian 1985 Accidents

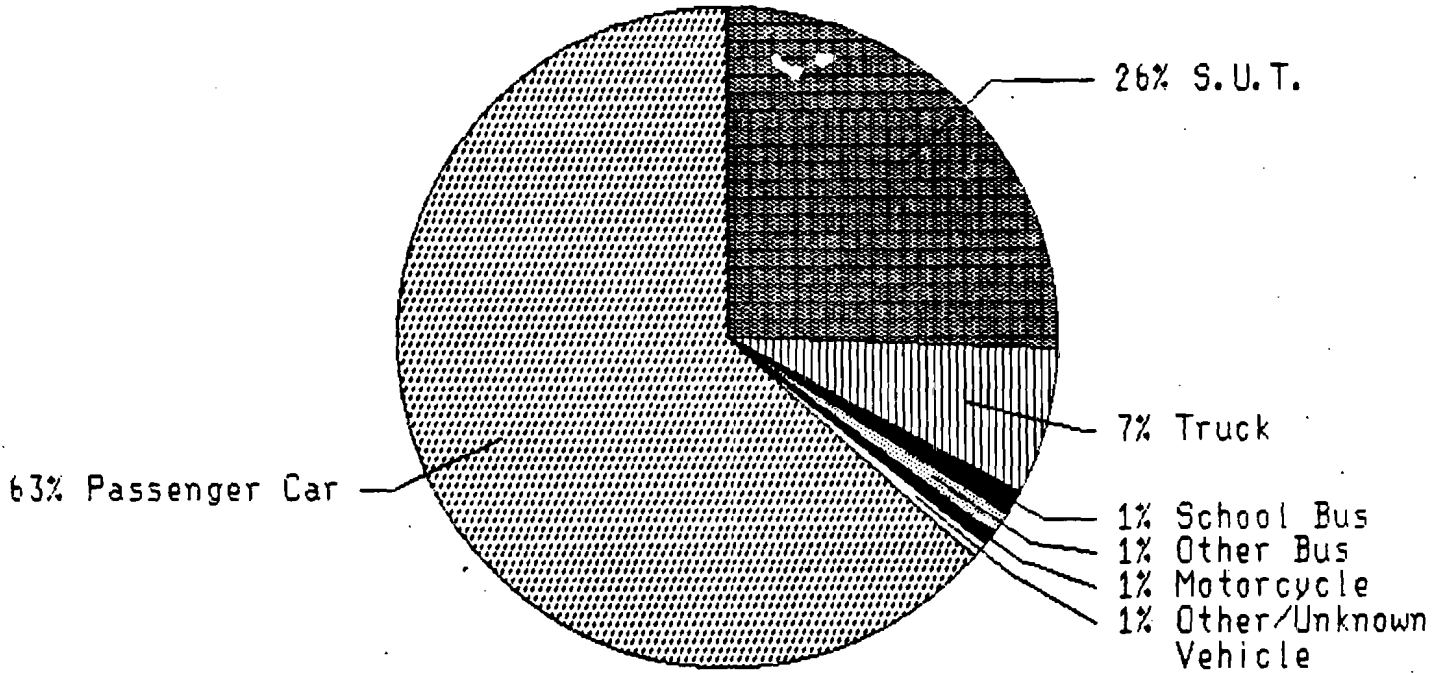

Injury Severity to Pedestrians Struck by Passenger Cars

1985

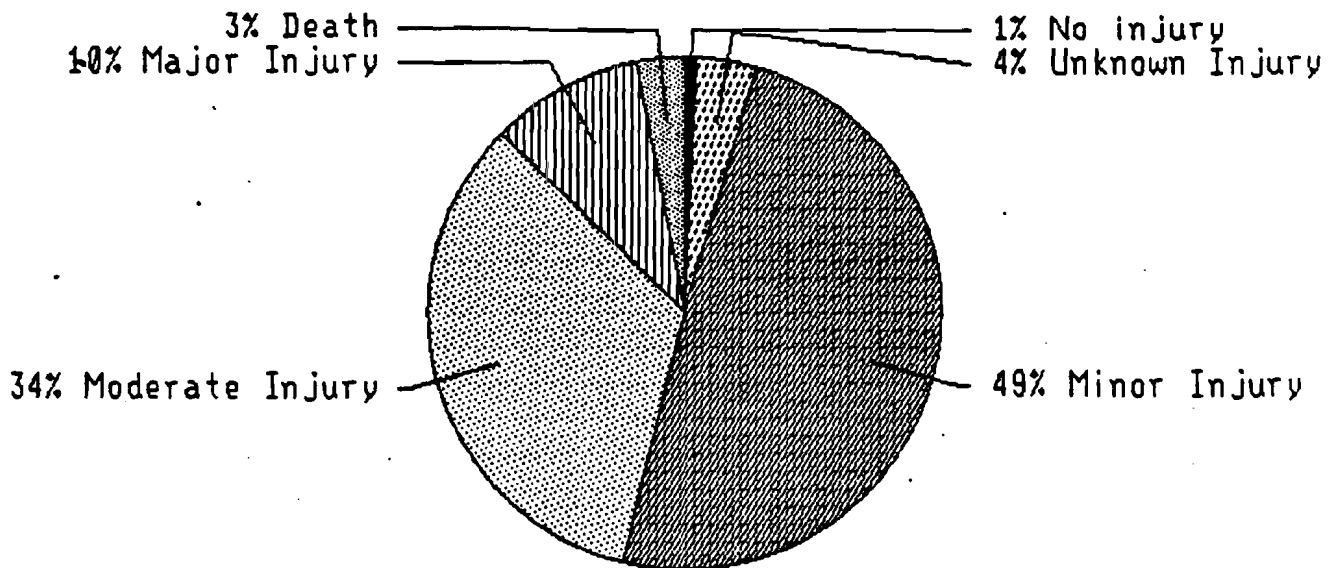

Injury Severity to Pedestrians Struck by Trucks

1985

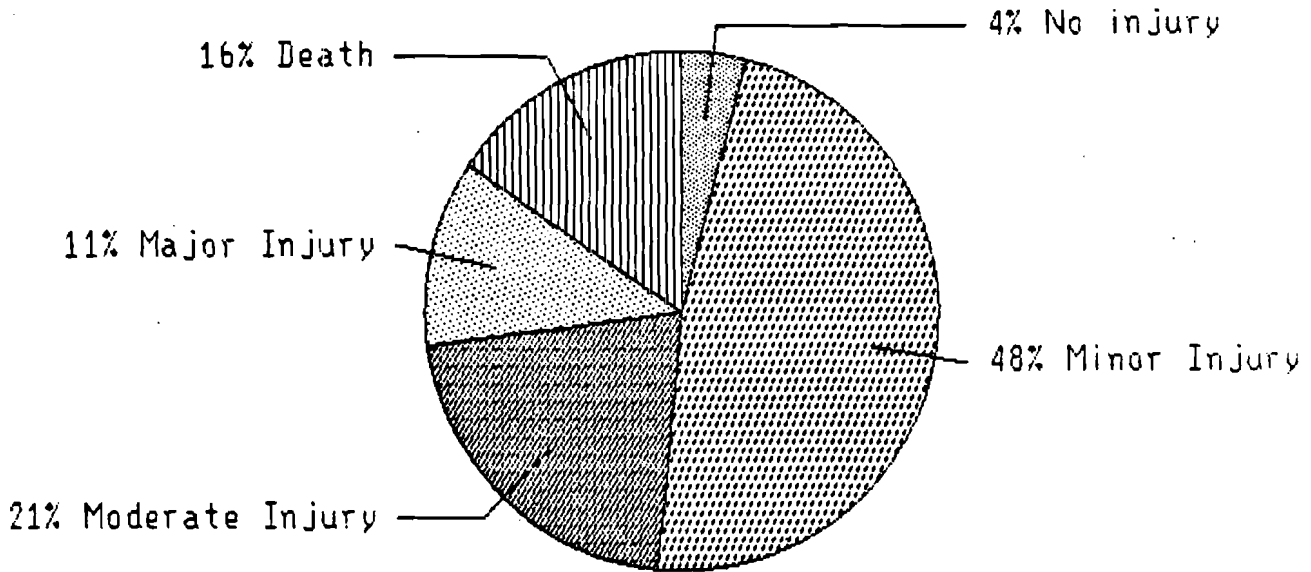

Injury Severity to Pedestrians Struck by Single Unit Trucks

1985

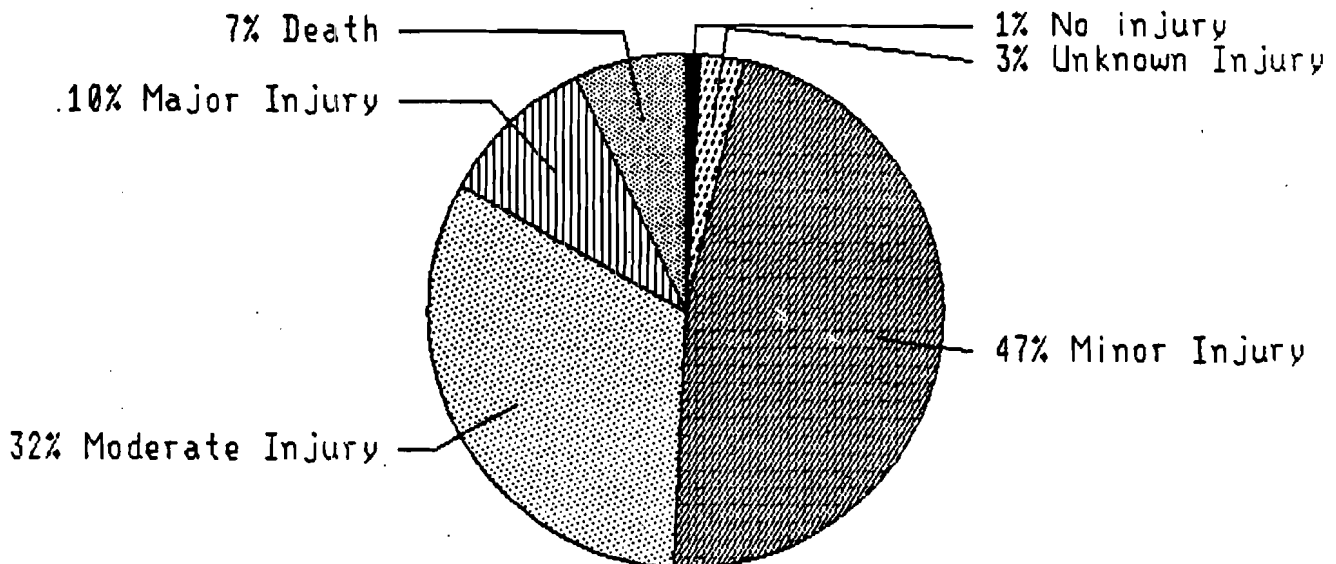

**Injury Severity to Pedestrians
Struck by School Buses**

1985

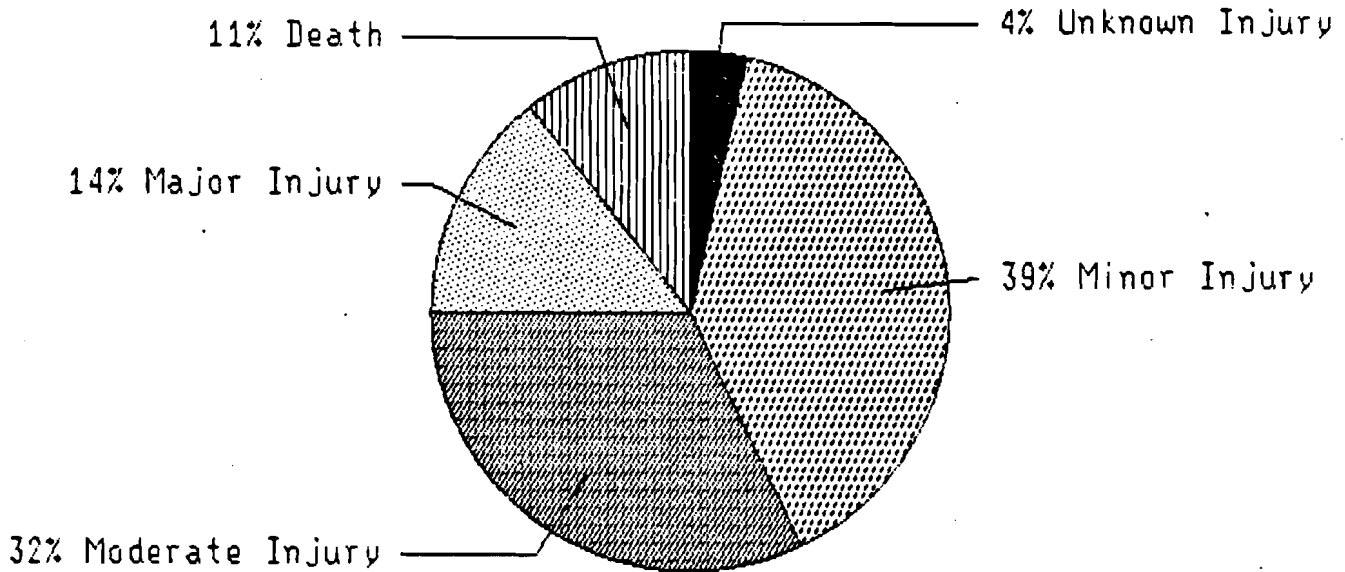

**Injury Severity to Pedestrians
Struck by Motorcycles**

1985

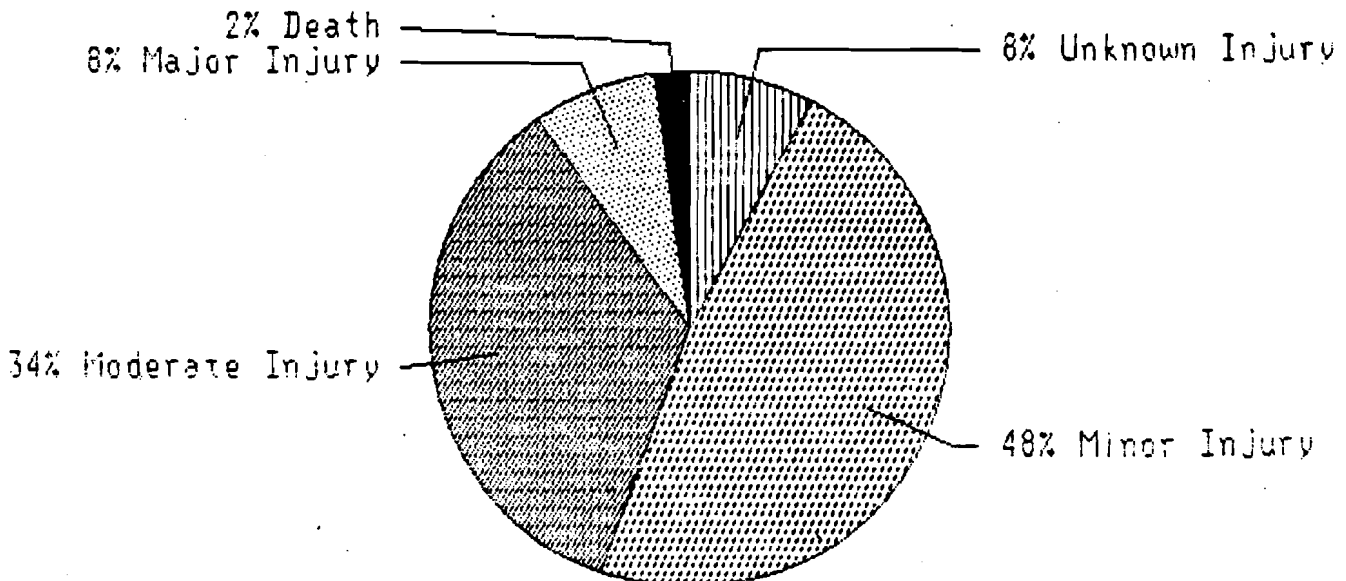

**SPECIAL INFORMATION
BY VEHICLE TYPE**

- A. Passenger Cars
- B. Trucks
- C. Motorcycles
- D. Pedalcycles
- E. Buses and School Buses

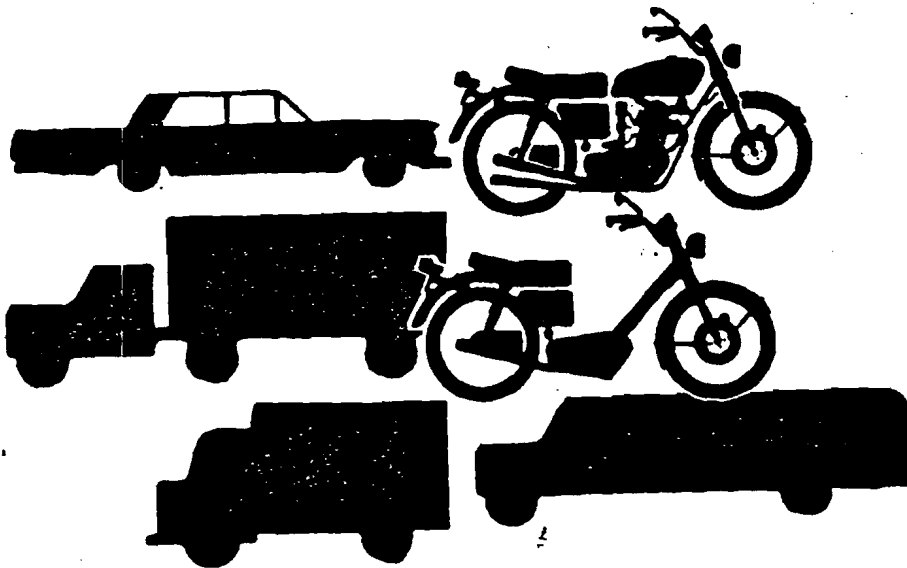

SPECIAL INFORMATION BY VEHICLE TYPE

SINGLE VEHICLE NON-COLLISION ACCIDENTS

1985

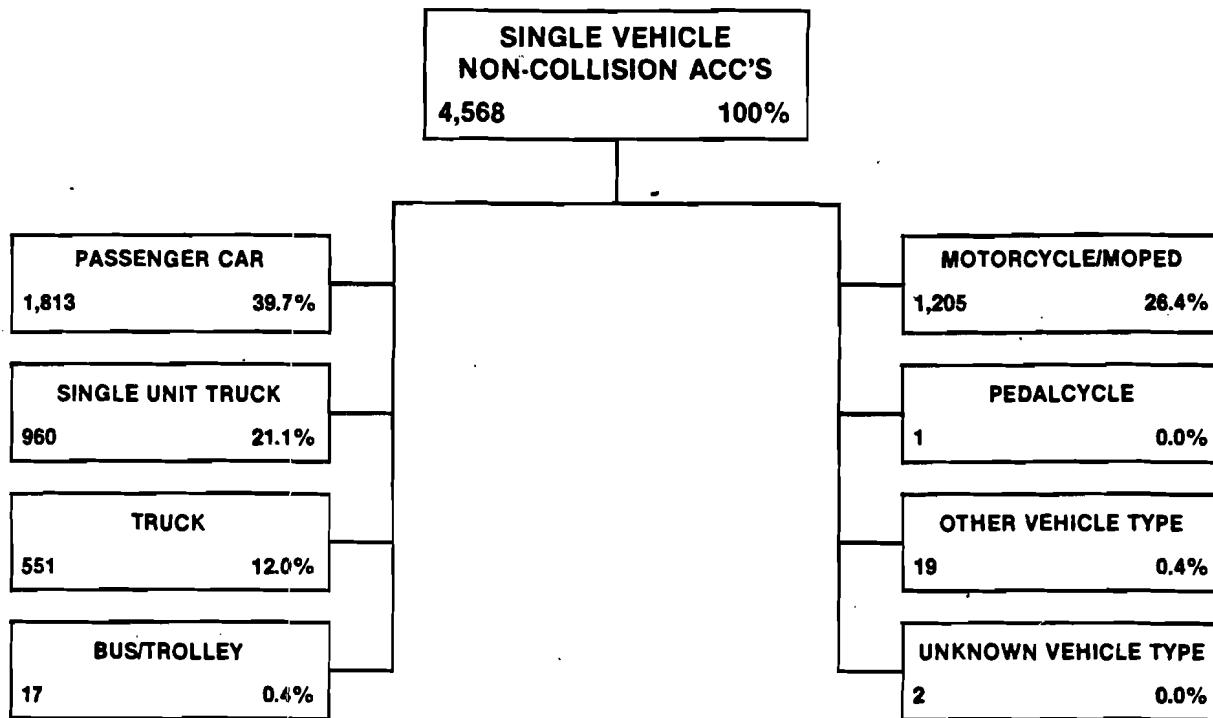

SINGLE VEHICLE HIT PEDESTRIAN ACCIDENTS

1985

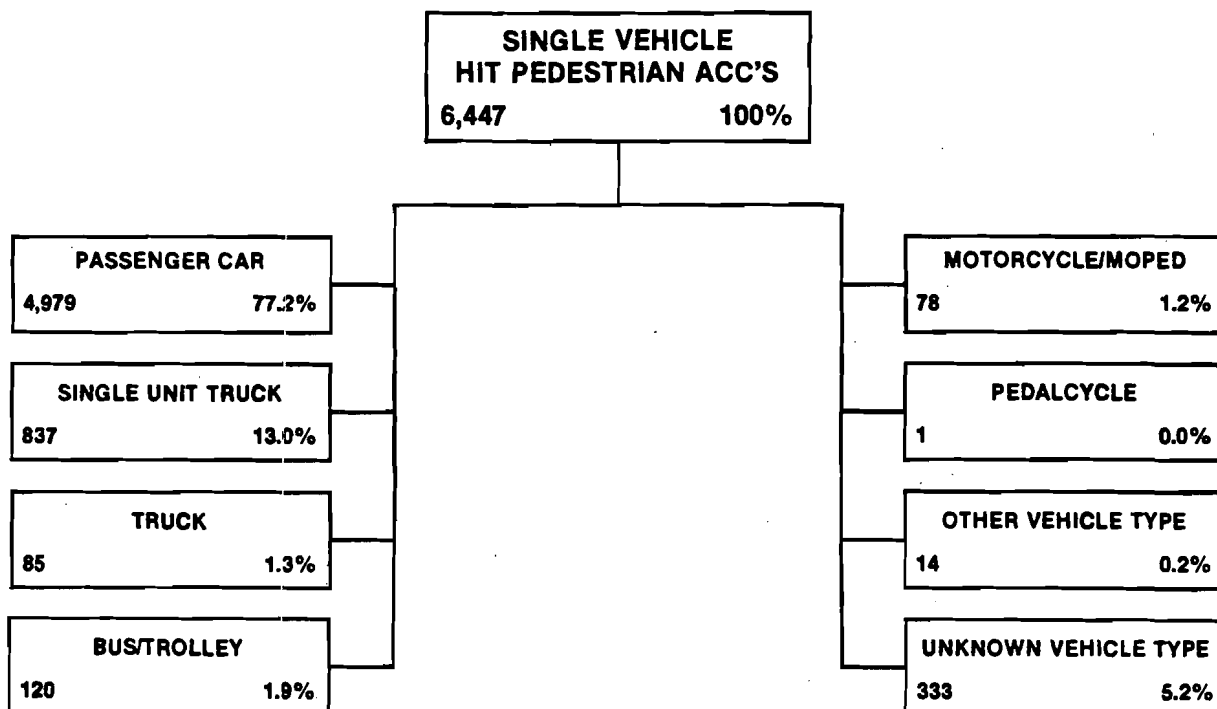

SINGLE VEHICLE HIT FIXED OBJECT ACCIDENTS 1985

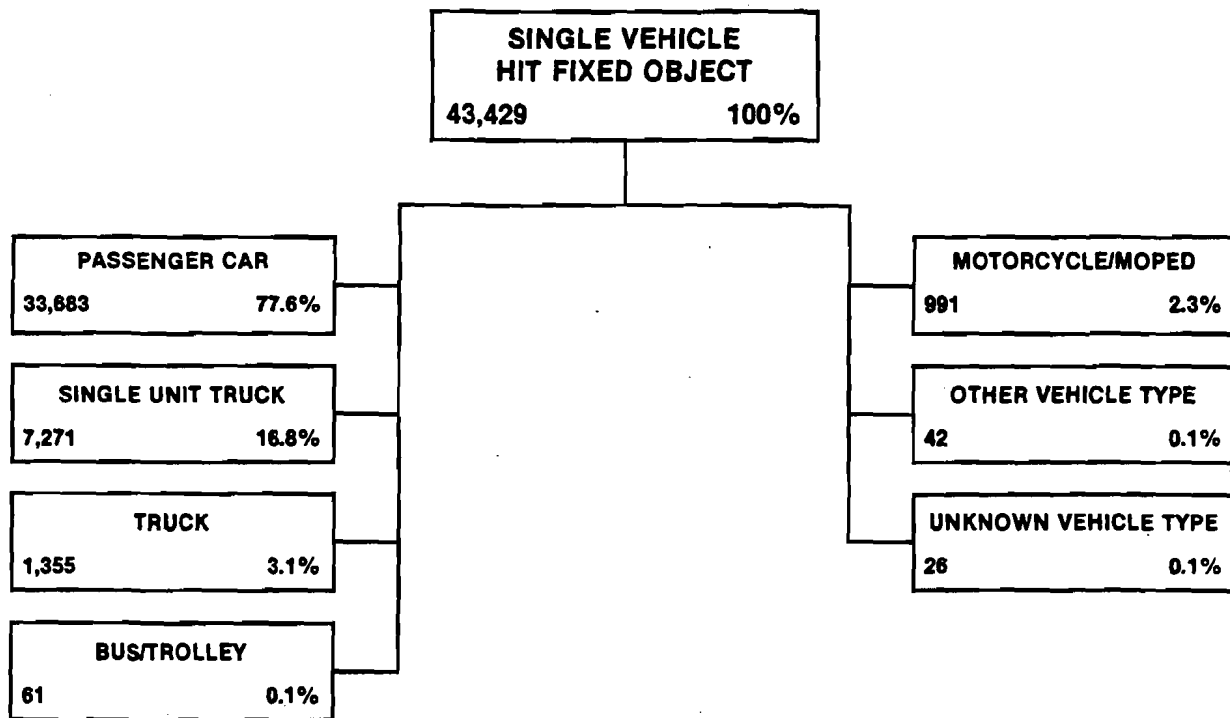

1985

TWO VEHICLE COLLISIONS*

	Car	Single Unit Truck	Truck	Bus/ Trolley	Motorcycle/ Moped	Pedalcycle	Other Vehicle	Unknown Vehicle
Car	40,899	14,879	2,977	743	2,399	2,787	423	622
Single Unit Truck		1,720	605	142	407	371	117	42
Truck			301	38	28	22	20	8
Bus/ Trolley				12	19	20	3	8
Motorcycle/ Moped					57	43	14	34
Pedalcycle						0	1	147
Other Vehicle							3	2
Unknown Vehicle								5

*INCLUDES ACCIDENTS WHERE TWO VEHICLES COLLIDED AND SUBSEQUENTLY STRUCK ONE OR MORE PARKED VEHICLES. THE TWO COLLIDING VEHICLES ARE COUNTED, BUT THE PARKED VEHICLES ARE NOT.

PASSENGER CAR ACCIDENTS

1985

	ALL ACCIDENTS	FATAL ACCIDENTS
Vehicle Registration:		
Pennsylvania	175,225 (93.1%)	1,434 (91.7%)
Out of State	12,848 (6.8%)	129 (8.3%)
Not Applicable	9,955 (5.3%)	
Operator License:		
Pennsylvania	163,569 (86.9%)	1,376 (88.0%)
Out of State	129 (8.3%)	117 (7.5%)
Not Applicable	9,955 (5.3%)	43 (2.8%)

1985 PASSENGER CAR FATALITIES

PASSENGER CAR OCCUPANTS KILLED IN 1985: 1,059 (58.5% OF THE TOTAL HIGHWAY DEATHS IN 1985).

OPERATORS KILLED: 706 (66.7%)

PASSENGERS KILLED: 353 (33.3%)

PASSENGER CAR FATALITIES BY SEATING POSITION:

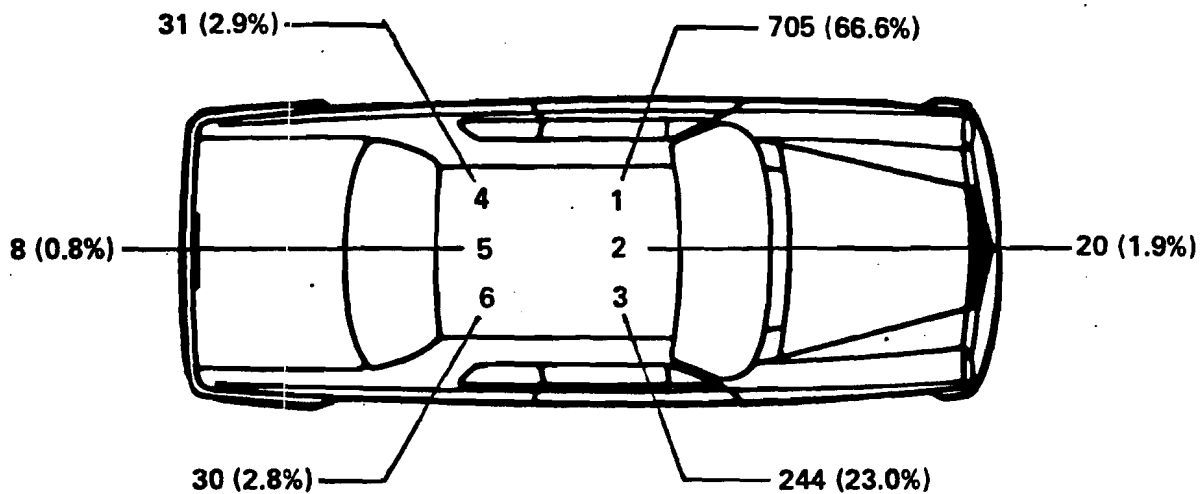

7 = 1 (OPERATOR OUTSIDE VEHICLE) (0.1%)

8 = 17 (OCCUPANTS) (1.6%)

LEGEND:

- 1 = DRIVER
- 2 = CENTER FRONT
- 3 = RIGHT FRONT
- 4 = LEFT REAR PASSENGER OR MOTORCYCLE/PEDALCYCLE REAR PASSENGER OR LEFT SIDE PASSENGERS ON A BUS OR VAN, ETC.
- 5 = CENTER REAR
- 6 = RIGHT REAR PASSENGER OR MOTORCYCLE SIDECAR PASSENGER OR RIGHT SIDE PASSENGERS ON A BUS OR VAN, ETC.
- 7 = PEDESTRIAN
- 8 = ANY PERSON IN THE REAR MOST SEATS OF A STATION WAGON; PERSONS IN THE REAR OF A PICKUP TRUCK; ANY PERSON RIDING ON OR ATTACHED TO THE OUTSIDE OF A VEHICLE.

1985

PASSENGER CAR FATALITIES

1,059

100%

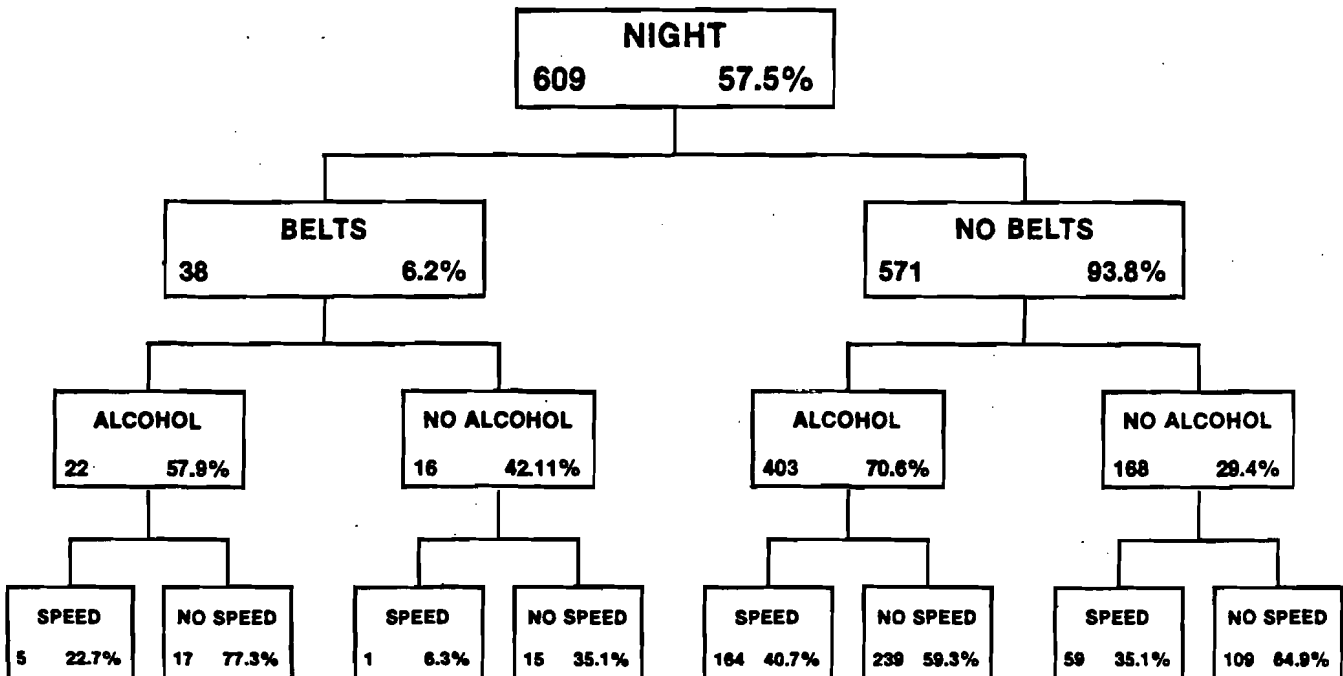
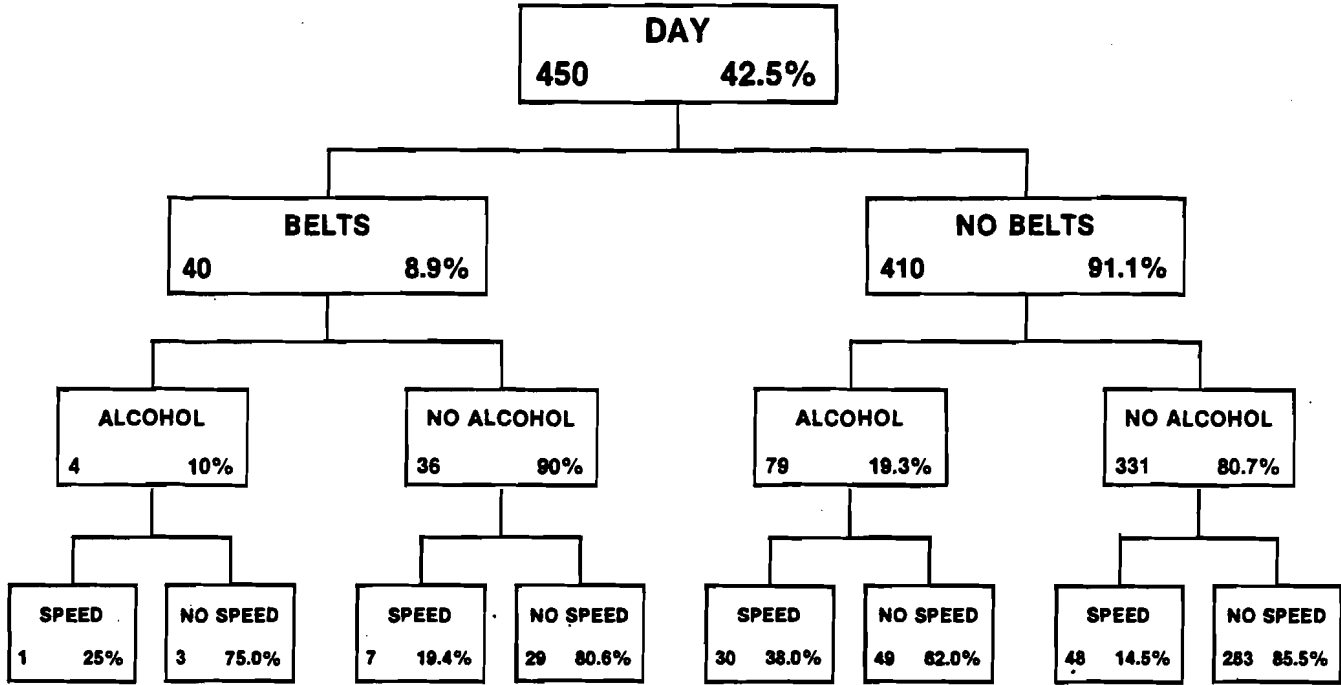

Type of Passenger Car Involved in 1985 Accidents

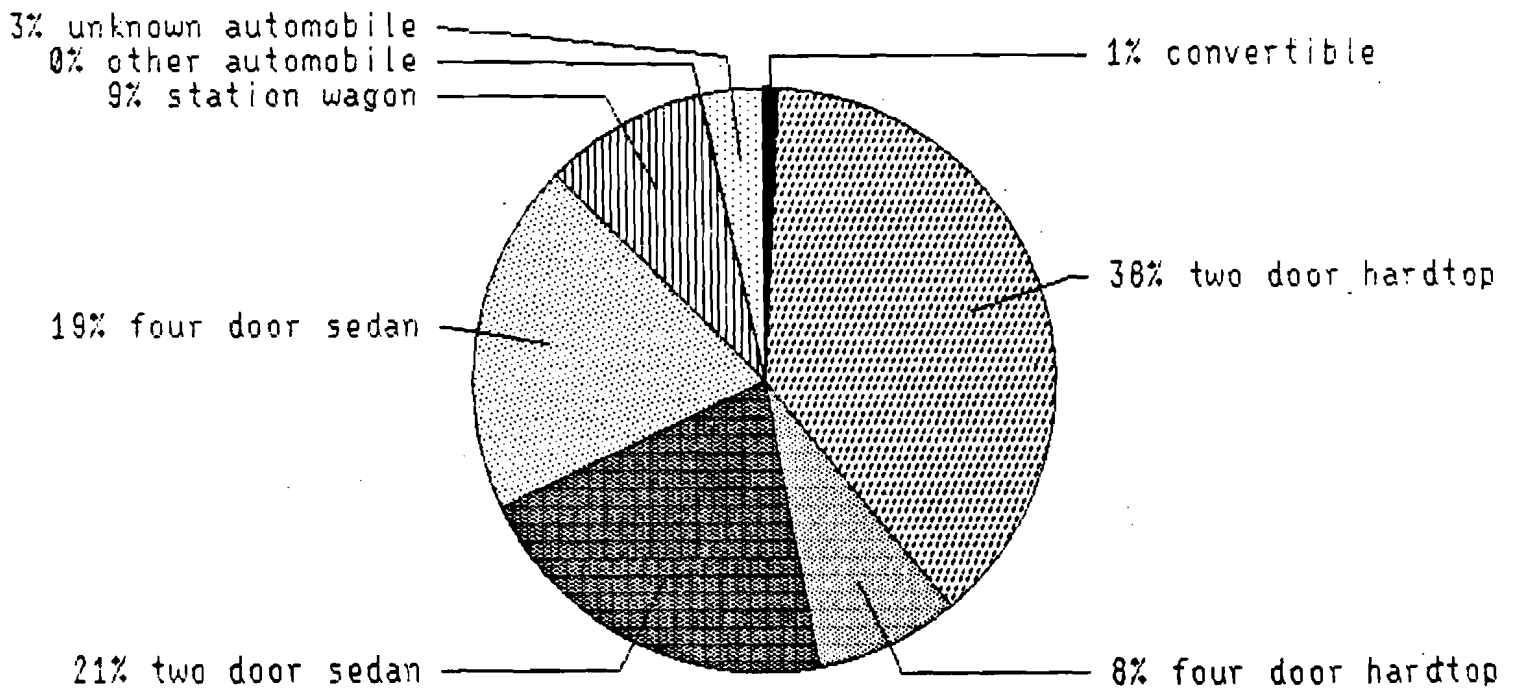

Passenger Car Operators Involved in 1985 Accidents Distribution by Age and Sex*

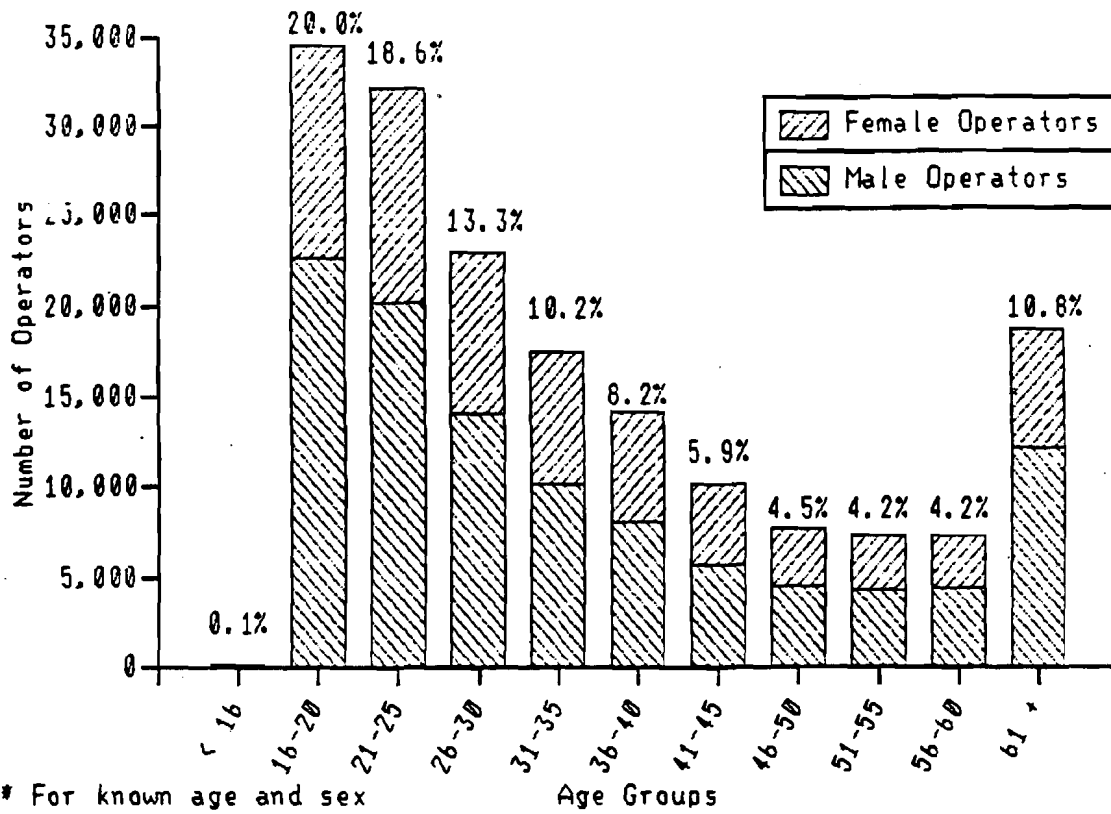

Passenger Car Operators Driving Under the Influence Distribution by Age and Sex* 1985 Accidents

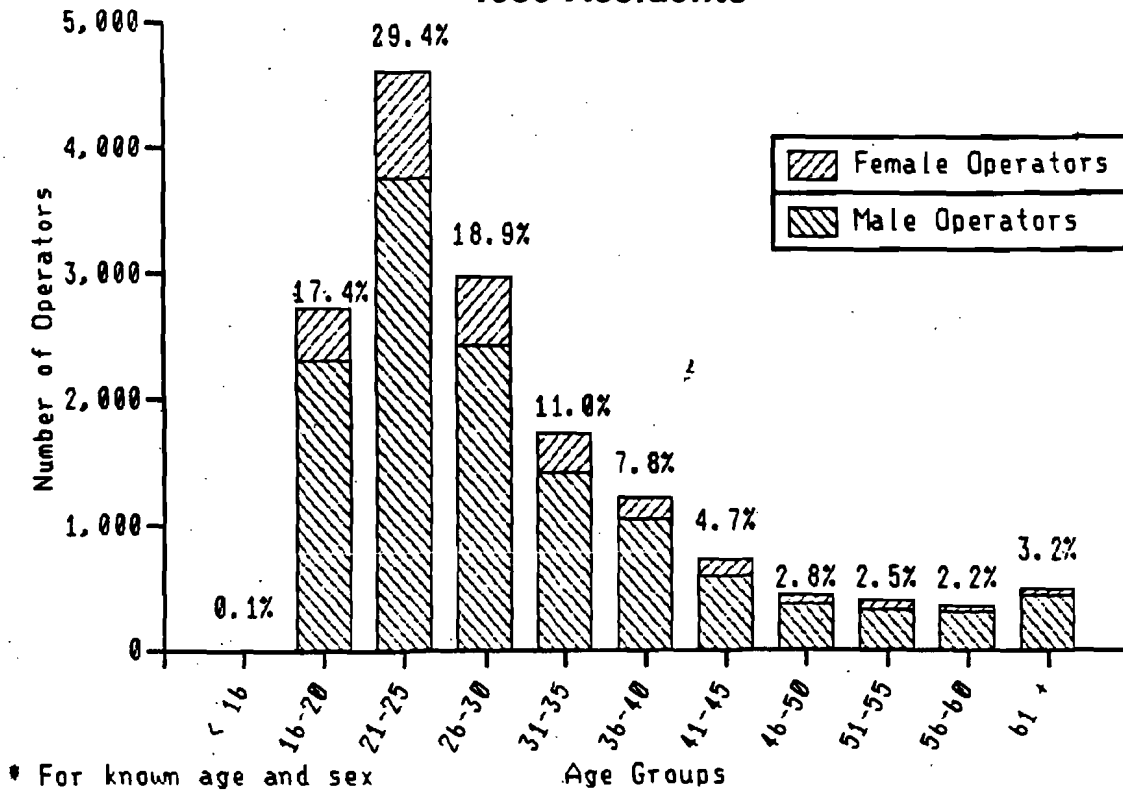

**SINGLE UNIT TRUCKS ACCIDENTS
1985**

	ALL ACCIDENTS	FATAL ACCIDENTS
Vehicle Registration:		
Pennsylvania	33,810 (92.4%)	462 (92.4%)
Out of State	2,751 (7.5%)	37 (7.4%)
Not Applicable	33 (0.1%)	1 (0.2%)
Operator License:		
Pennsylvania	31,919 (87.2%)	438 (87.6%)
Out of State	2,452 (6.7%)	34 (6.8%)
No License	215 (0.6%)	3 (0.6%)
Not Applicable	2,008 (5.5%)	25 (5.0%)

1985 SINGLE UNIT TRUCK FATALITIES

SINGLE UNIT TRUCK OCCUPANTS KILLED IN 1985: 214 (11.8% OF THE TOTAL HIGHWAY DEATHS IN 1985).

OPERATORS KILLED: 57 (73.4%)

PASSENGERS KILLED: 57 (26.6%)

SINGLE UNIT TRUCK FATALITIES BY SEATING POSITION:

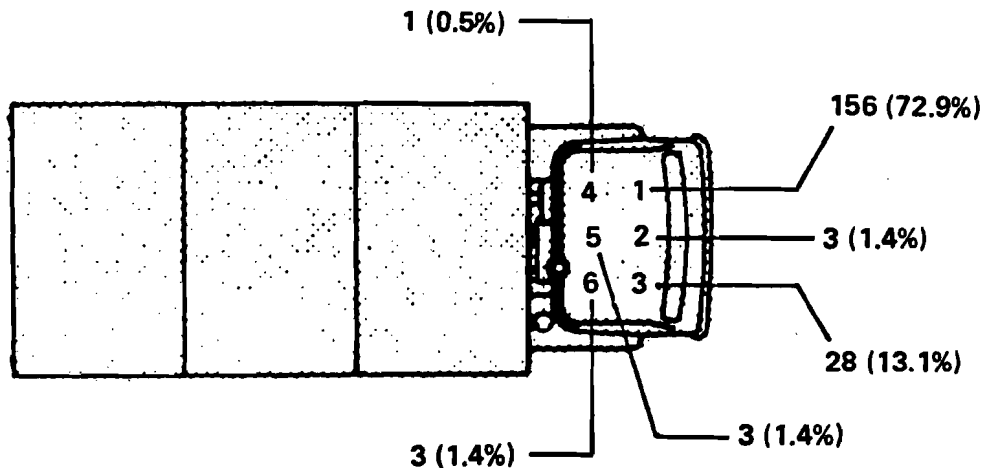

7 = 1 (0.5%) (OPERATOR)

9 = 7 (3.3%) (PASSENGERS)

LEGEND:

- 1 = DRIVER
- 2 = CENTER FRONT
- 3 = RIGHT FRONT
- 4 = LEFT REAR PASSENGER OR MOTORCYCLE/PEDALCYCLE REAR PASSENGER OR LEFT SIDE PASSENGERS ON A BUS OR VAN, ETC.
- 5 = CENTER REAR
- 6 = RIGHT REAR PASSENGER OR MOTORCYCLE SIDECAR PASSENGER OR RIGHT SIDE PASSENGERS ON A BUS OR VAN, ETC.
- 7 = PEDESTRIAN
- 8 = ANY PERSON IN THE REAR MOST SEATS OF A STATION WAGON; PERSONS IN THE REAR OF A PICKUP TRUCK; ANY PERSON RIDING ON OR ATTACHED TO THE OUTSIDE OF A VEHICLE.

1985

SINGLE UNIT TRUCK FATALITIES

214 100%

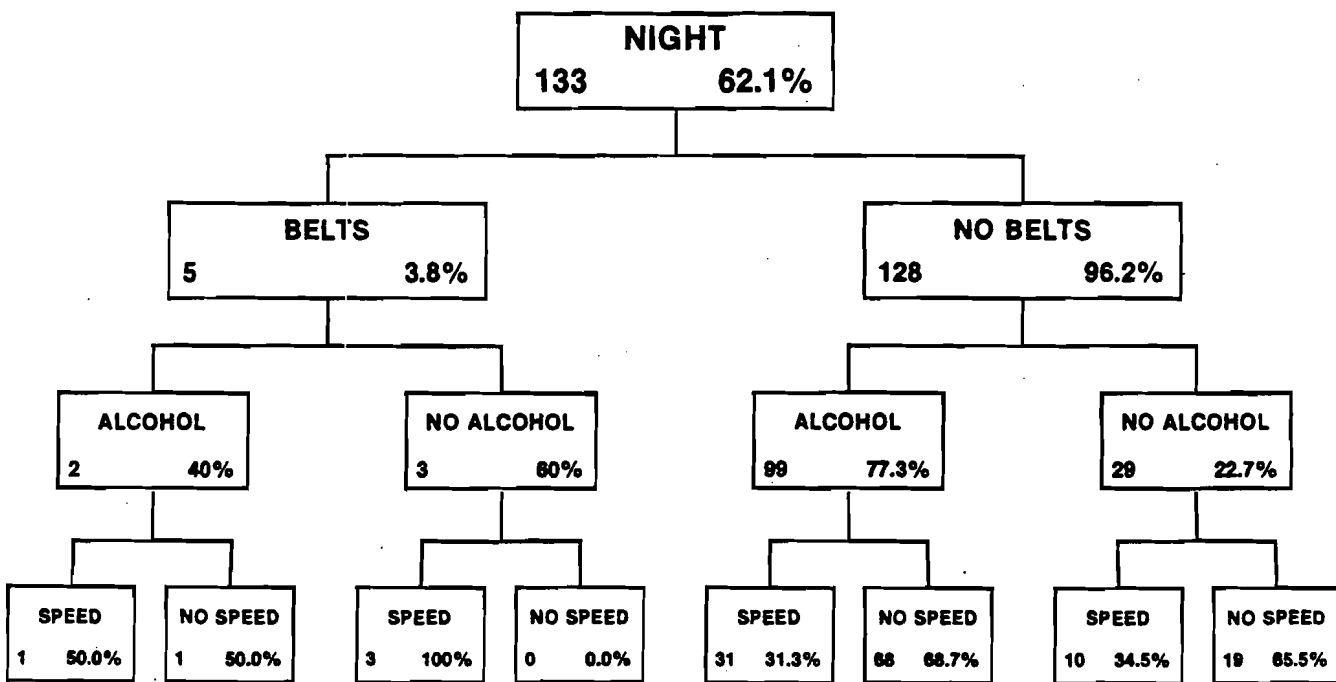
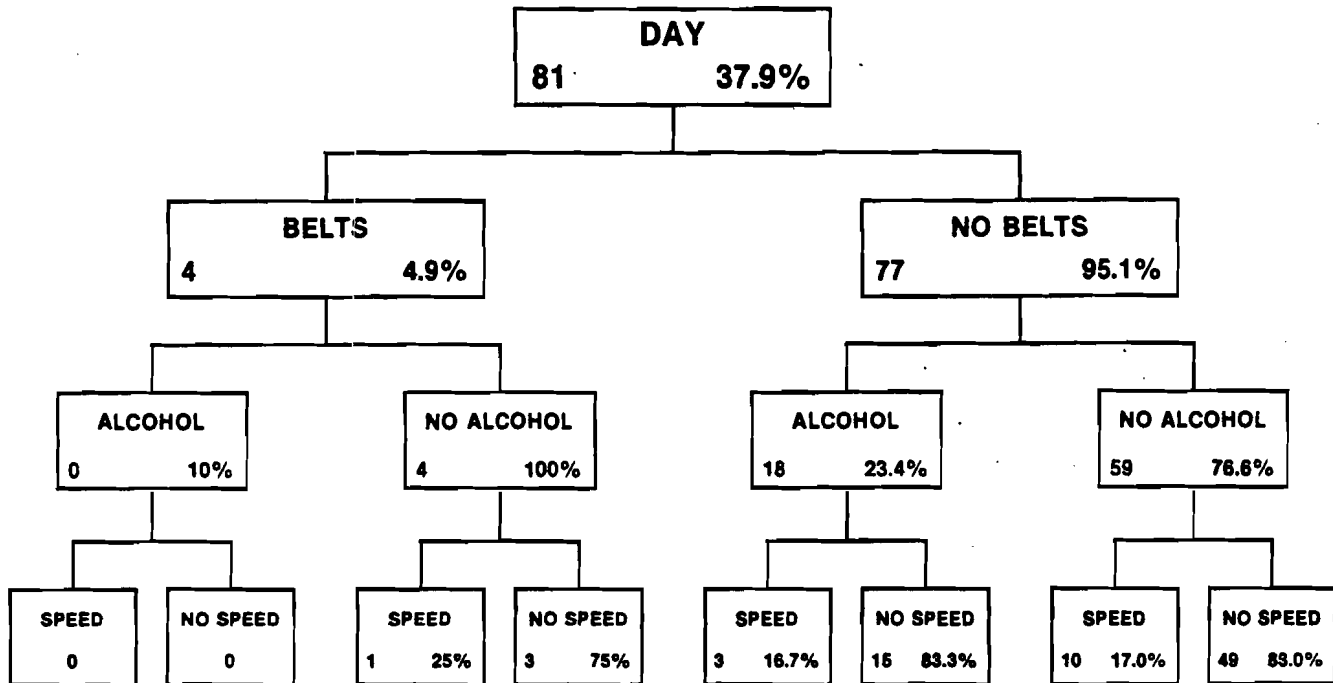

Type of Single Unit Truck Involved in 1985 Accidents

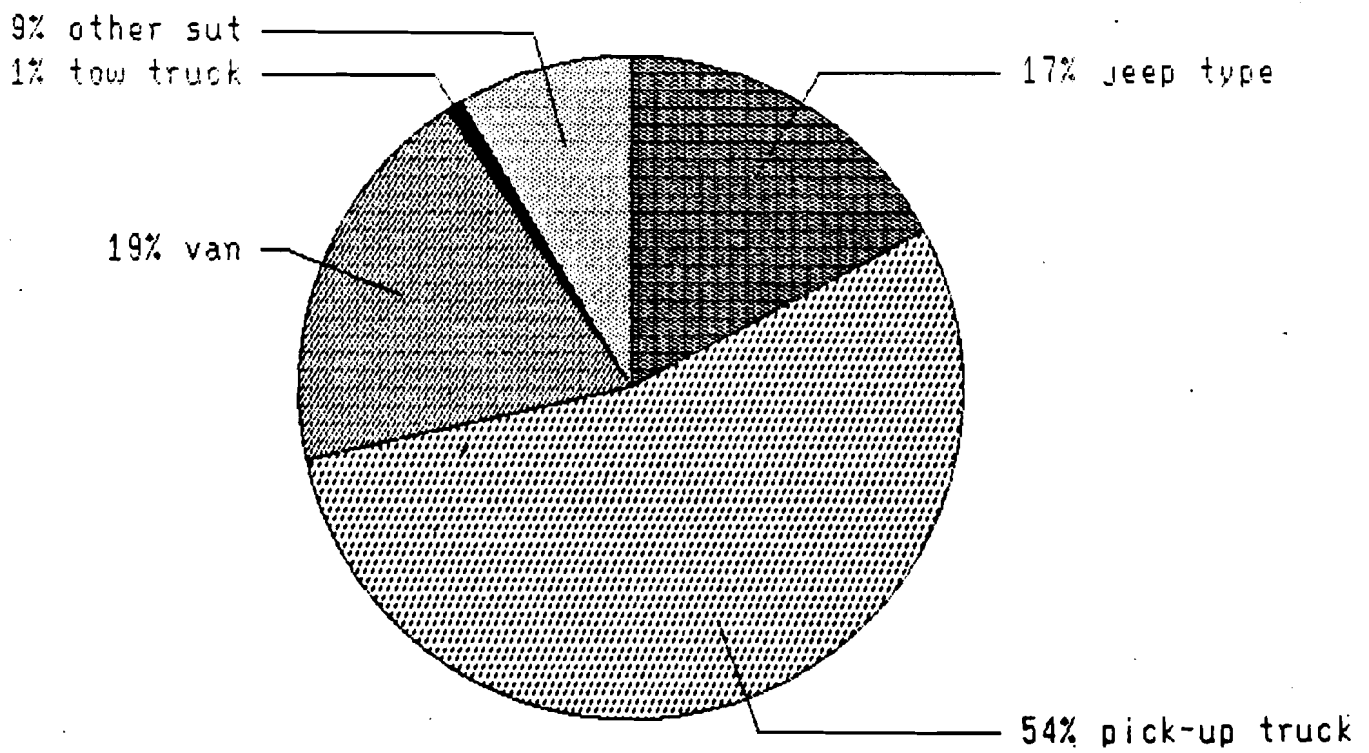

Single Unit Truck Operators Involved in 1985 Accidents Distribution by Age and Sex*

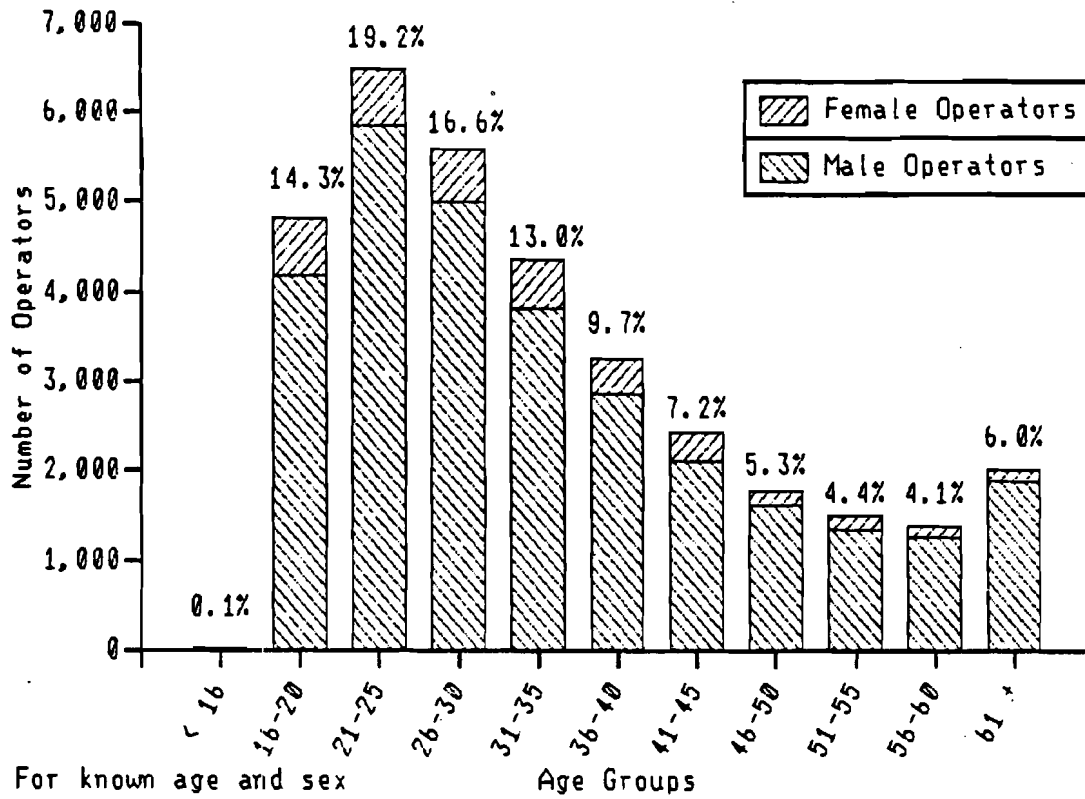

Single Unit Truck Operators Driving Under the Influence Distribution by Age and Sex* 1985 Accidents

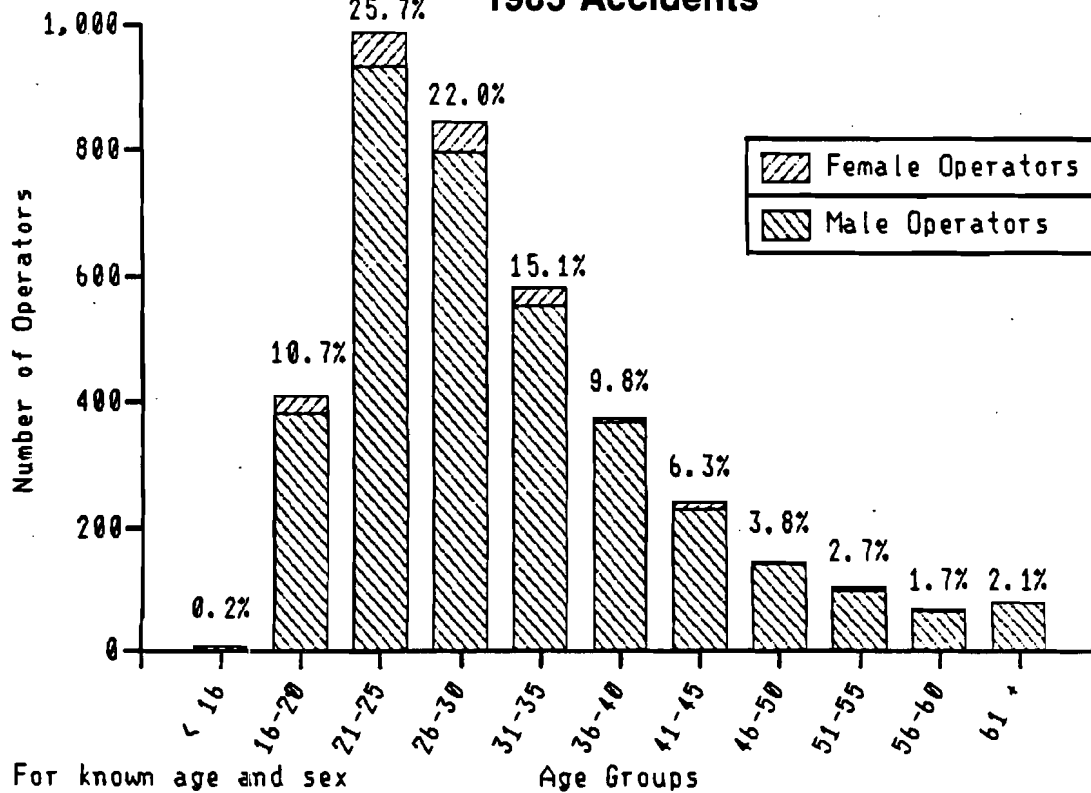

**TRUCK ACCIDENTS
1985**

	ALL ACCIDENTS	FATAL ACCIDENTS
Vehicle Registration:		
Pennsylvania	4,029 (51.2%)	90 (39.6%)
Out of State	3,833 (48.7%)	137 (60.4%)
Not Applicable	11 (0.1%)	
Operator License:		
Pennsylvania	4,525 (57.5%)	117 (51.5%)
Out of State	3,077 (39.1%)	104 (45.8%)
No License	15 (0.2%)	1 (0.4%)
Not Applicable	256 (3.2%)	5 (2.2%)

1985 TRUCK FATALITIES

TRUCK OCCUPANTS KILLED IN 1985: 53 (2.9% OF THE TOTAL HIGHWAY DEATHS IN 1985).

OPERATORS KILLED: 41 (77.4%)

PASSENGERS KILLED: 11 (20.8%)

UNKNOWN KILLED: 1 (1.8%)

TRUCK FATALITIES BY SEATING POSITION:

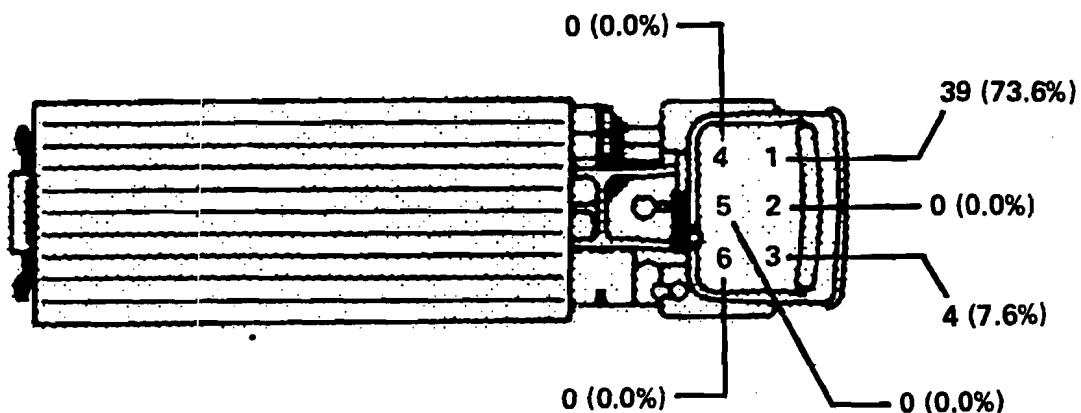

7 = 1 (1.9%) (OPERATOR)

9 = 1 (1.9%) (OPERATOR)

LEGEND:

- 1 = DRIVER
- 2 = CENTER FRONT
- 3 = RIGHT FRONT
- 4 = LEFT REAR PASSENGER OR MOTORCYCLE/PEDALCYCLE REAR PASSENGER OR LEFT SIDE PASSENGERS ON A BUS OR VAN, ETC.
- 5 = CENTER REAR
- 6 = RIGHT REAR PASSENGER OR MOTORCYCLE SIDECAR PASSENGER OR RIGHT SIDE PASSENGERS ON A BUS OR VAN, ETC.
- 7 = PEDESTRIAN
- 8 = ANY PERSON IN THE REAR MOST SEATS OF A STATION WAGON; PERSONS IN THE REAR OF A PICKUP TRUCK; ANY PERSON RIDING ON OR ATTACHED TO THE OUTSIDE OF A VEHICLE.

1985

TRUCK FATALITIES

53 100%

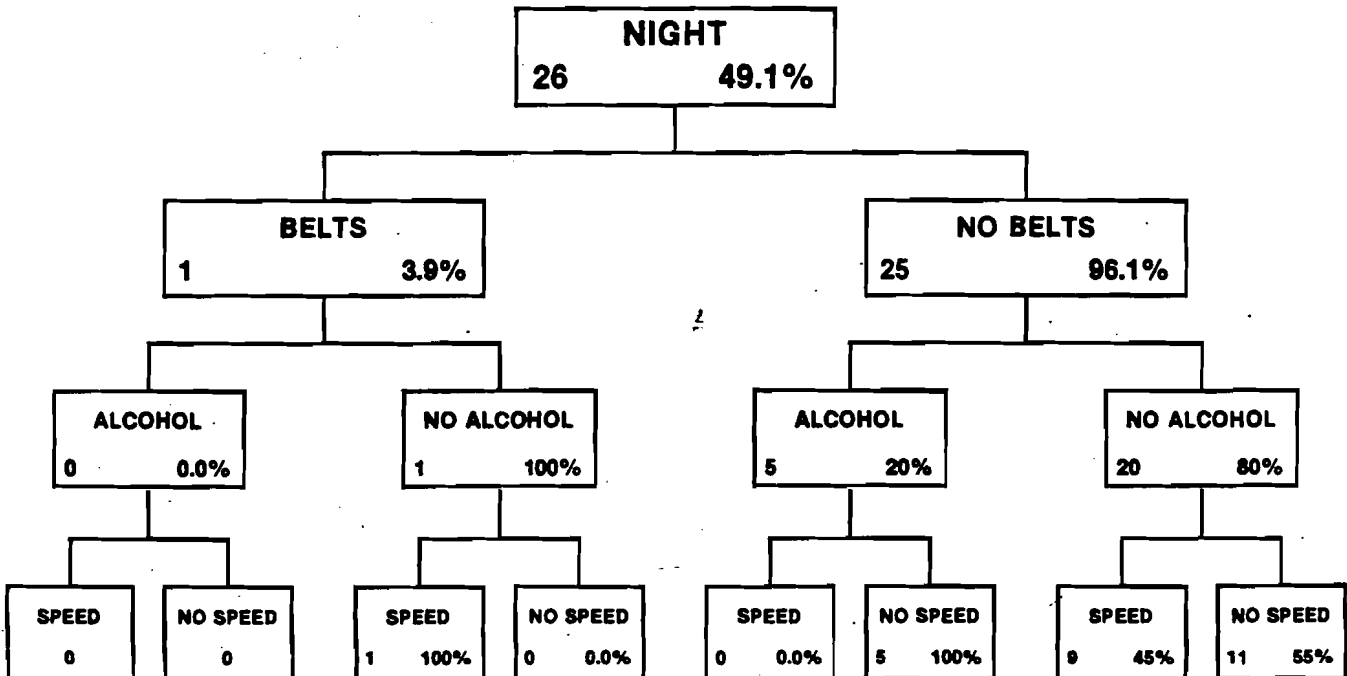
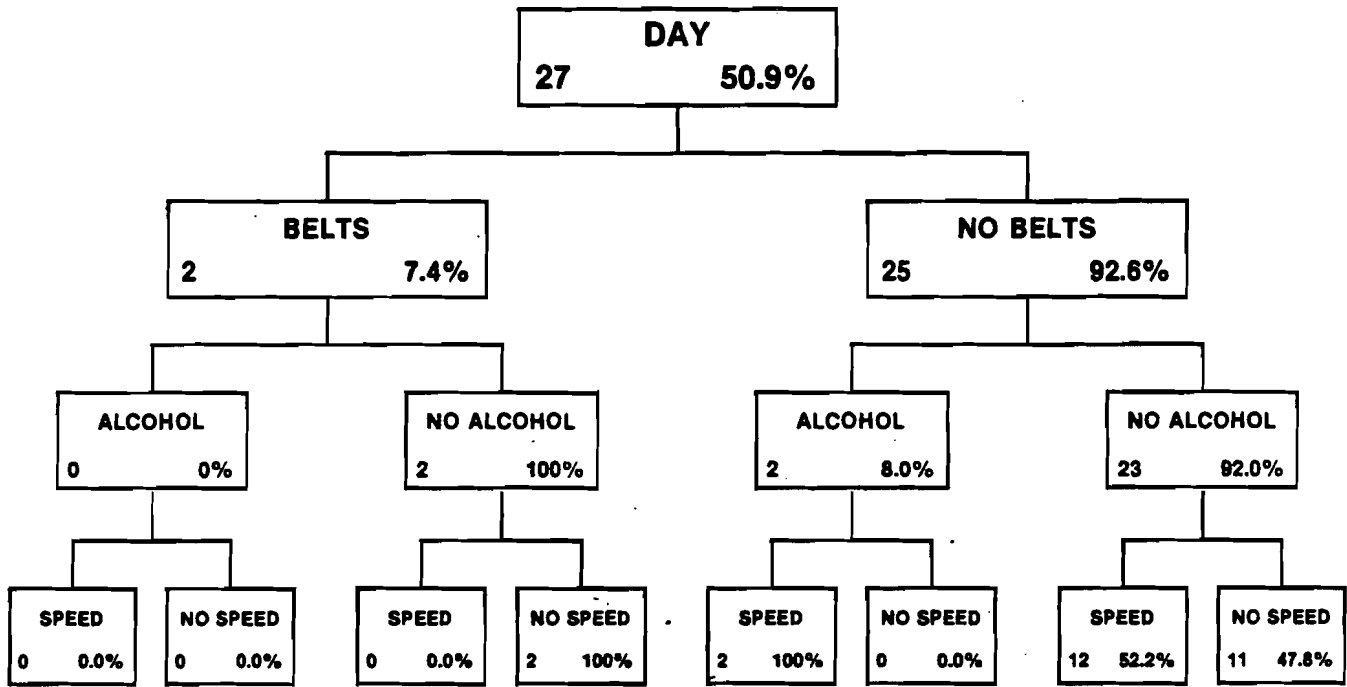

Type of Truck Involved in 1985 Accidents

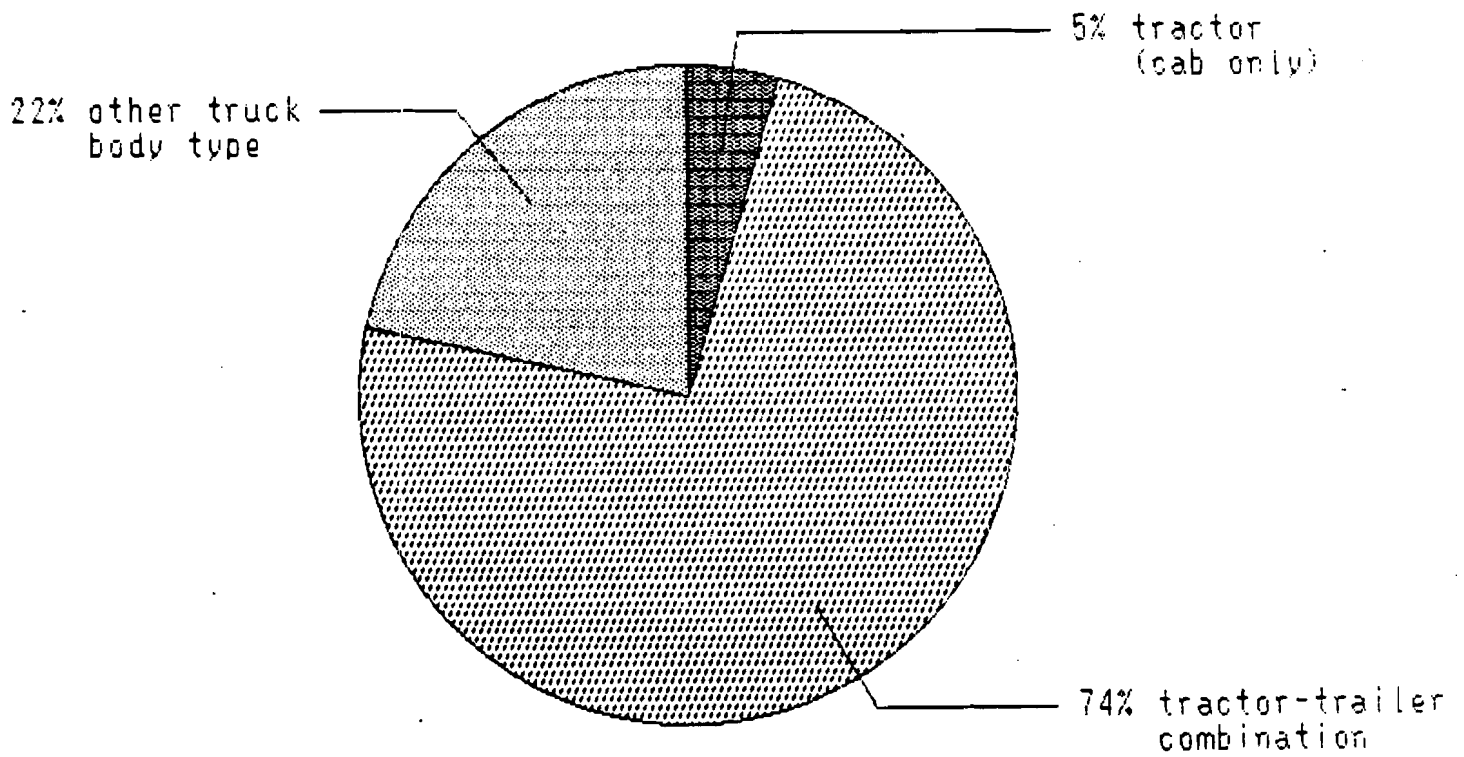

Truck Operators Driving Under the Influence Distribution by Age and Sex* 1985 Accidents

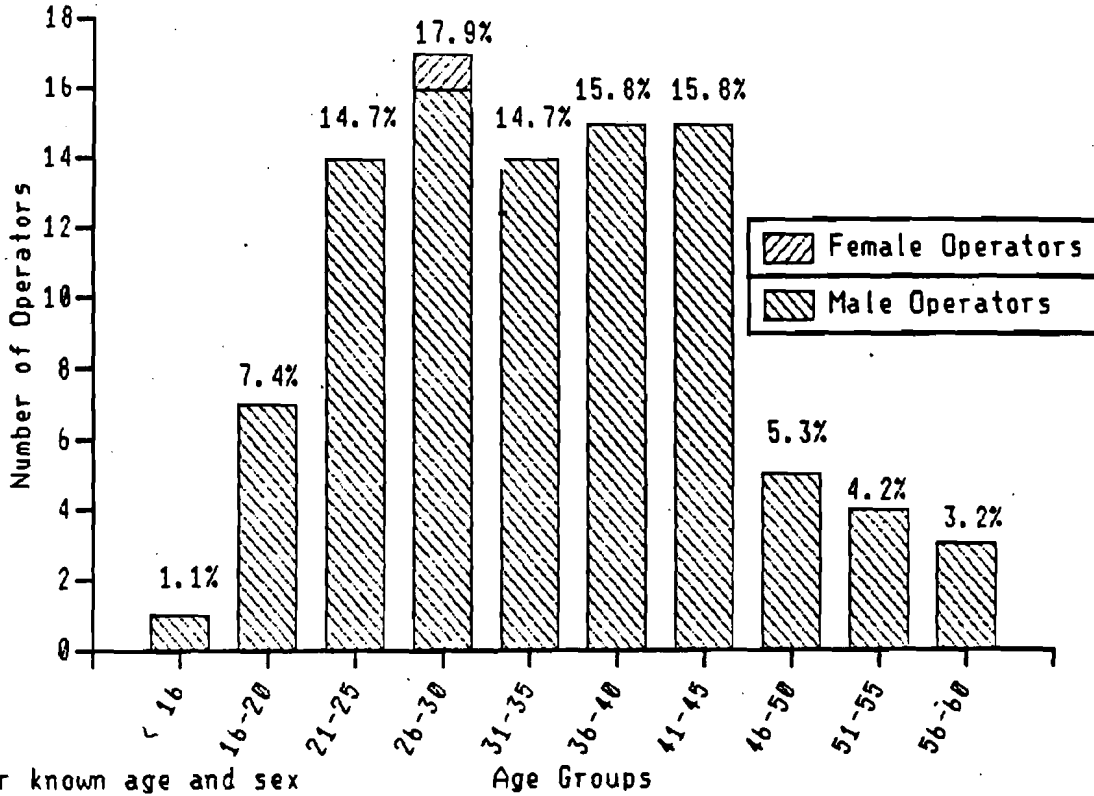

Truck Operators Involved in 1985 Accidents Distribution by Age and Sex*

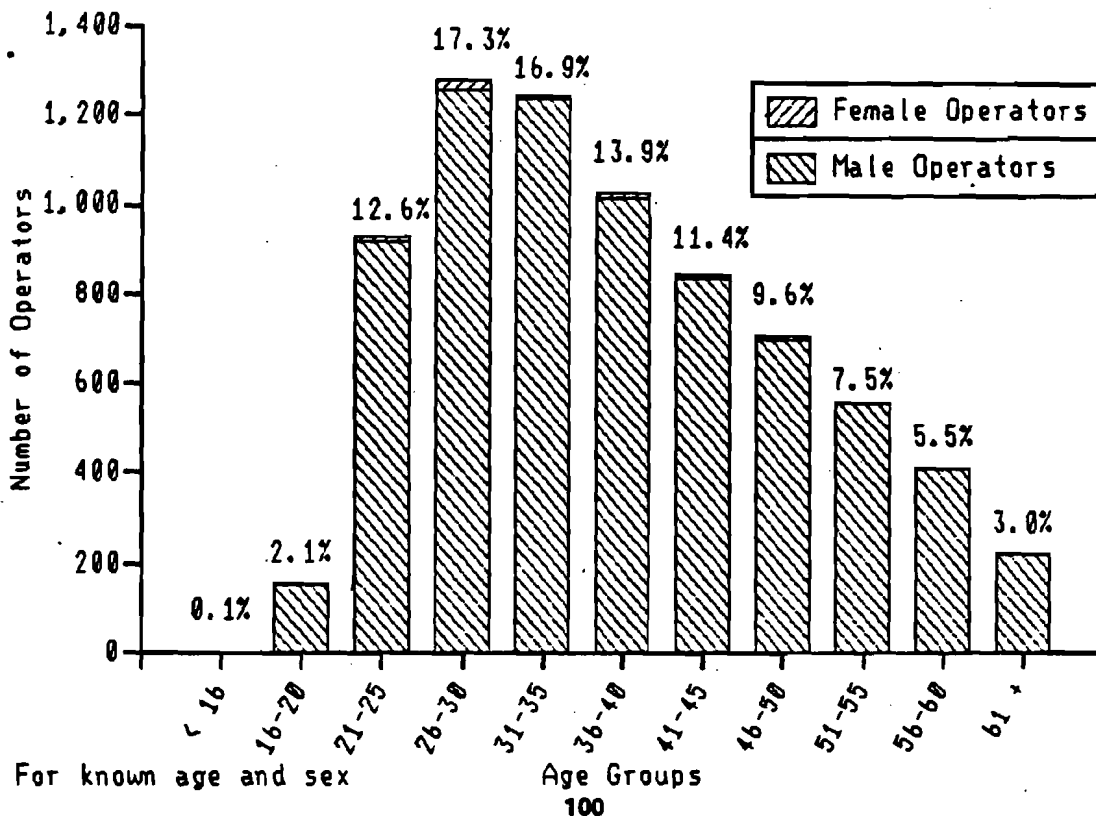

**MOTORCYCLE ACCIDENTS
1985**

	ALL ACCIDENTS	FATAL ACCIDENTS
Vehicle Registration:		
Pennsylvania	5,426 (92.1%)	153 (86.9%)
Out of State	359 (6.1%)	8 (4.5%)
Not Applicable	104 (1.8%)	15 (8.6%)
Operator License:		
Pennsylvania	5,183 (88.0%)	153 (86.9%)
Out of State	319 (5.4%)	9 (5.1%)
No License	328 (5.6%)	14 (8.0%)
Not Applicable	15 (8.6%)	

1985 MOTORCYCLE FATALITIES

MOTORCYCLE RIDERS KILLED IN 1985: 177 (9.8% OF THE TOTAL HIGHWAY DEATHS IN 1985).

OPERATORS KILLED: 157 (88.7%)

PASSENGERS KILLED: 20 (11.3%)

MOTORCYCLE FATALITIES BY SEATING POSITION:

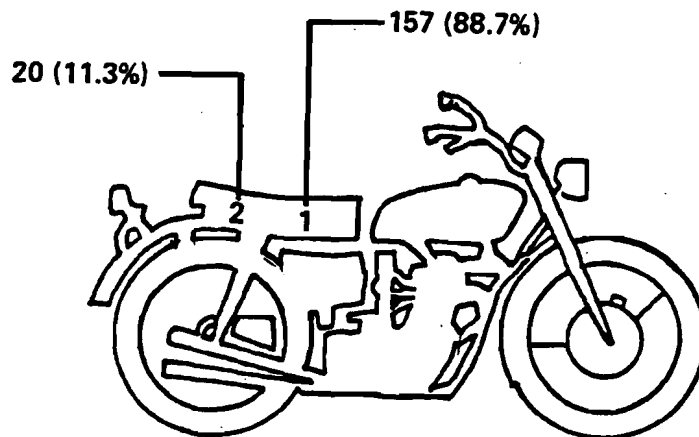

LEGEND:

1 = DRIVER

2 = LEFT REAR PASSENGER OR MOTORCYCLE/PEDALCYCLE REAR PASSENGER OR LEFT SIDE PASSENGERS ON A BUS OR VAN, ETC.

1985

MOTORCYCLE FATALITIES

177 100%

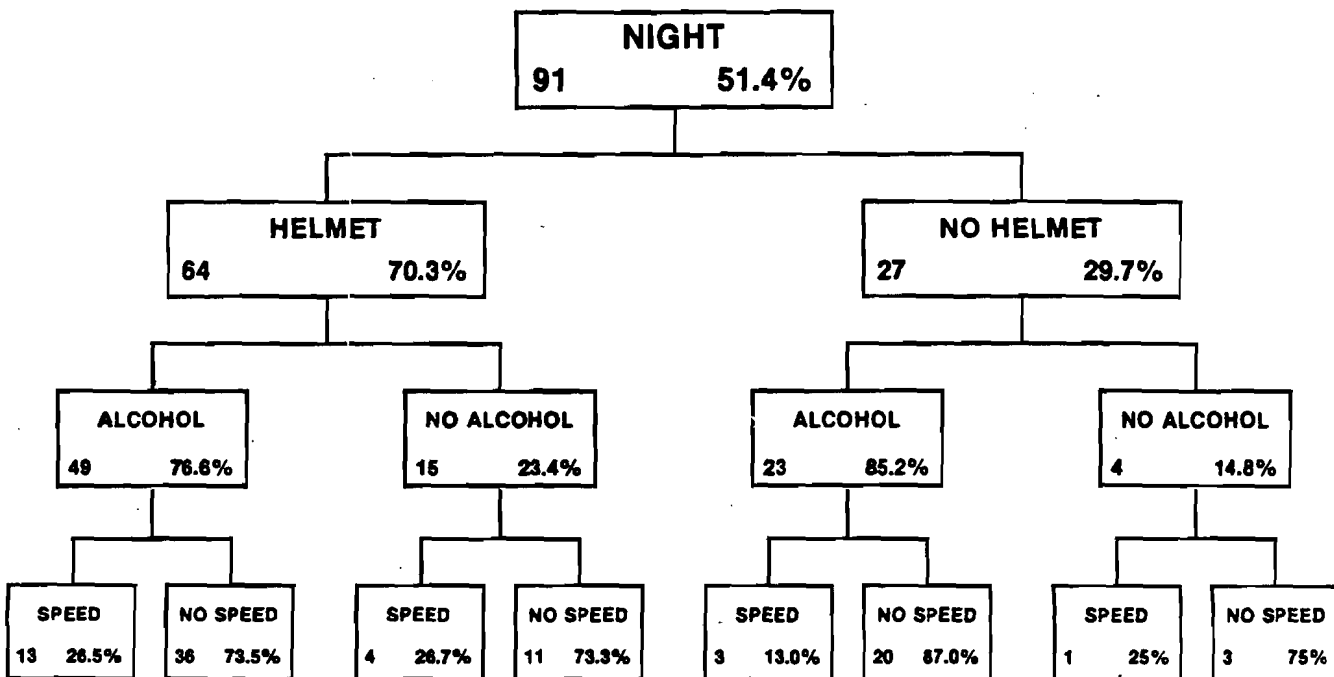
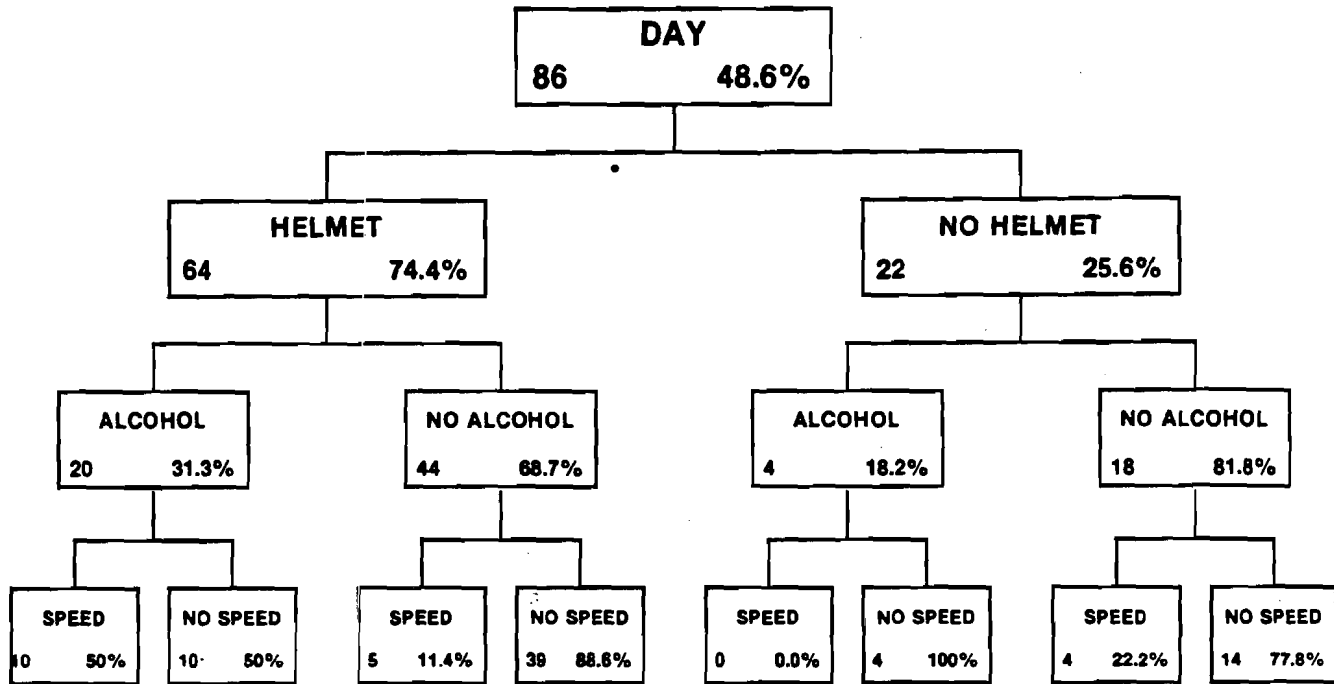

Type of Motorcycle Involved in 1985 Accidents

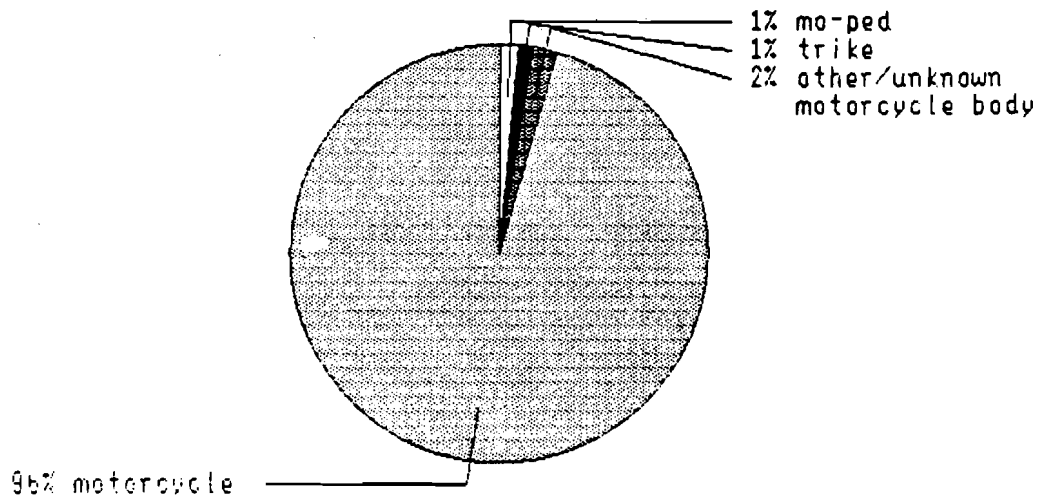

Motorcycle Body Type Operators Involved in 1985 Accidents Distribution by Age and Sex*

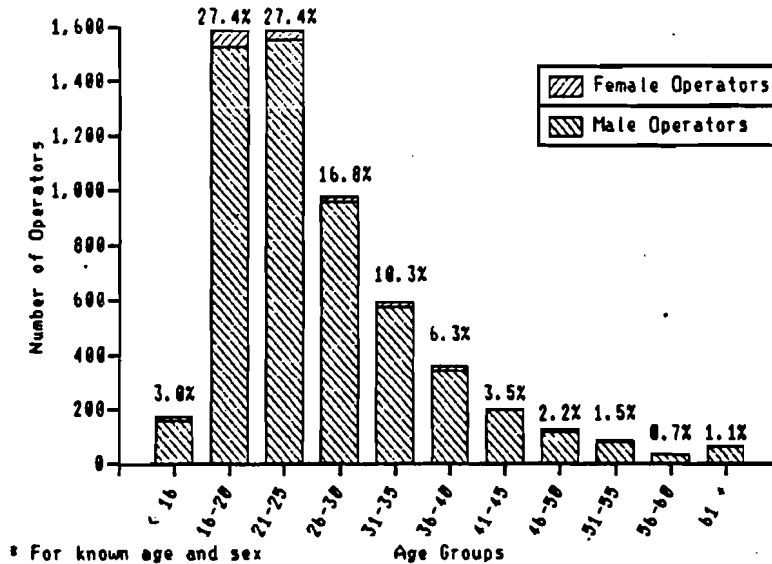

Motorcycle Body Type Operators Driving Under the Influence Distribution by Age and Sex* 1985 Accidents

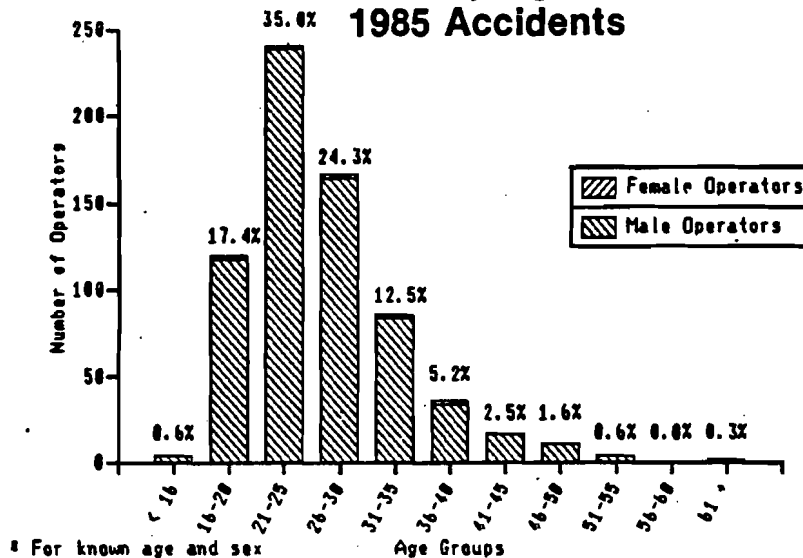

1985

PEDALCYCLIST FATALITIES

30 100%

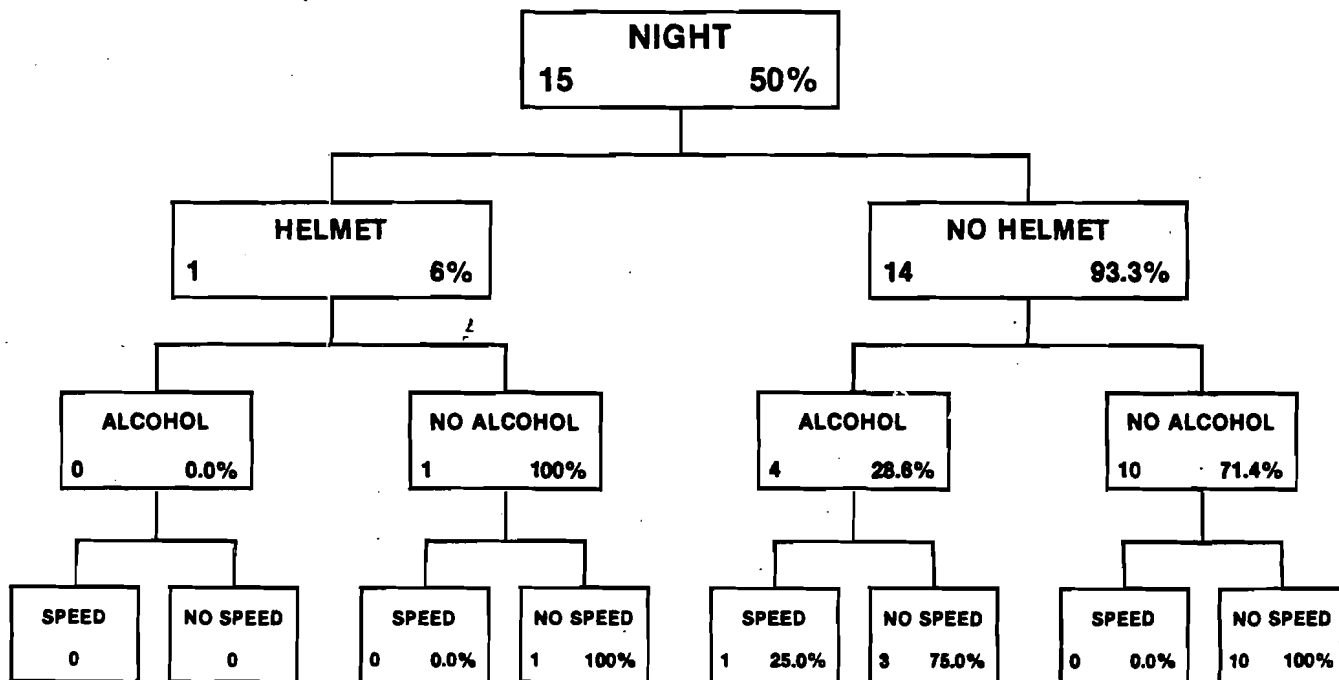
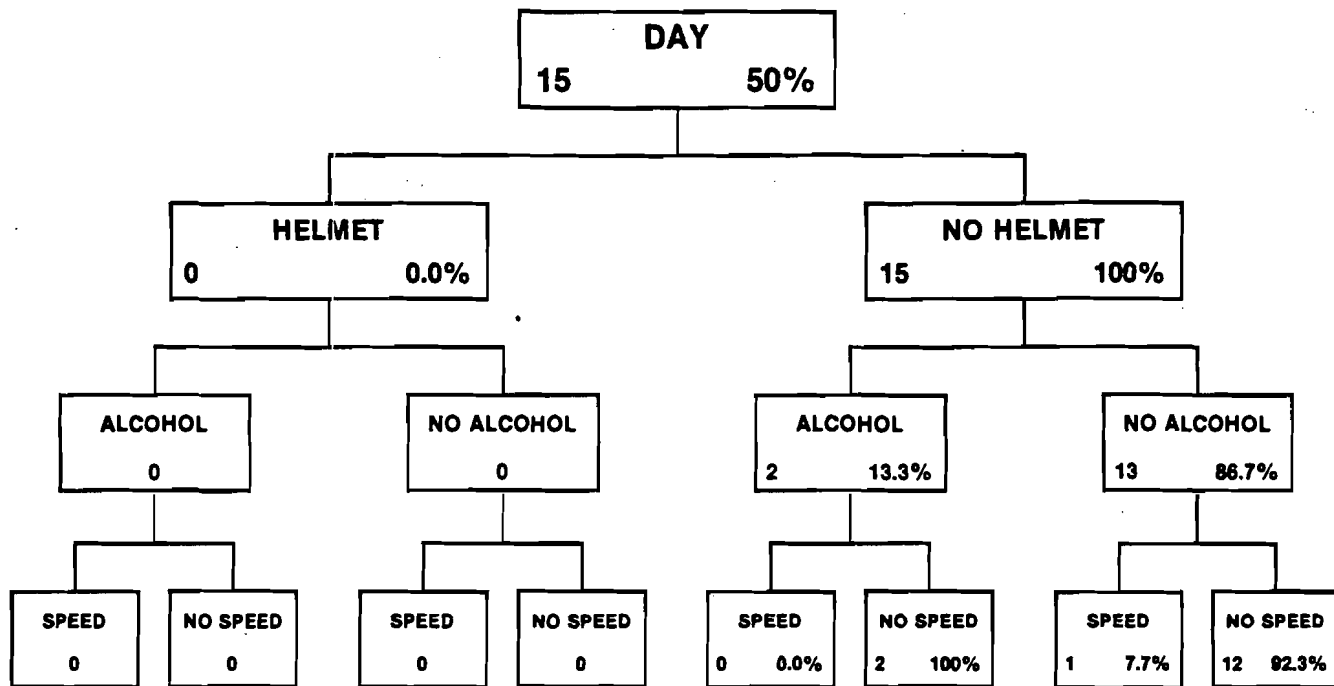

PEDALCYCLE ACCIDENTS

1985

NUMBER OF PEDALCYCLES INVOLVED IN AN ACCIDENT IN 1985: 3,484

NUMBER OF PEDALCYCLES INVOLVED IN FATAL ACCIDENTS IN 1985: 31

1985 PEDALCYCLIST FATALITIES

PEDALCYCLISTS KILLED IN 1985: 30 (1.7% OF THE TOTAL HIGHWAY DEATHS IN 1985).

OPERATORS KILLED: 29 (96.7%)

PASSENGERS KILLED: 1 (3.3%)

PEDALCYCLIST FATALITIES BY SEATING POSITION:

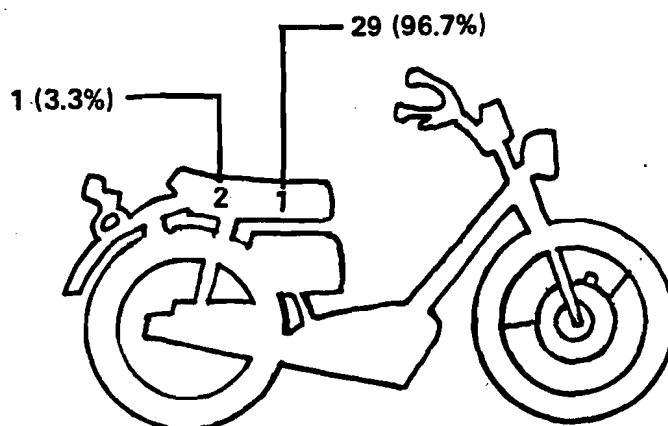

LEGEND:

- 1 = DRIVER
- 2 = LEFT REAR PASSENGER OR MOTORCYCLE/PEDALCYCLE REAR PASSENGER OR LEFT SIDE PASSENGERS ON A BUS OR VAN, ETC.

Pedalcycle Operators Driving Under the Influence Distribution by Age and Sex* 1985 Accidents

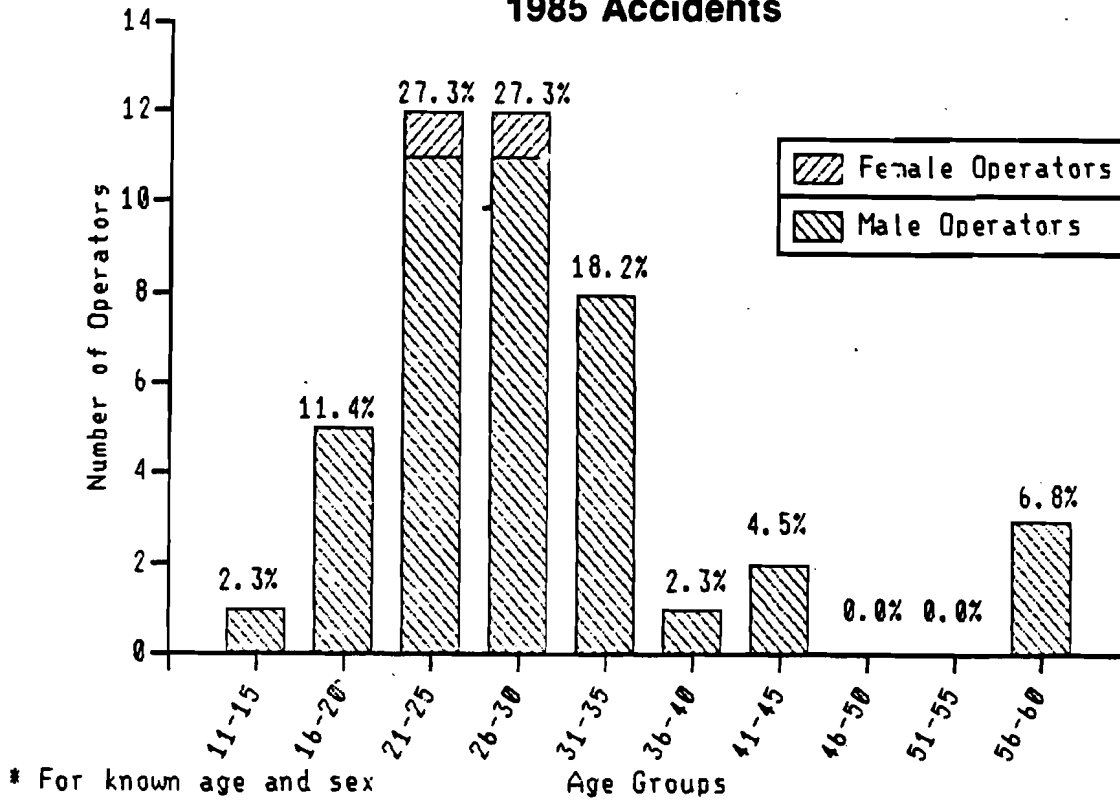

Pedalcyclists Involved in an Accident Distribution by Age and Sex* 1985

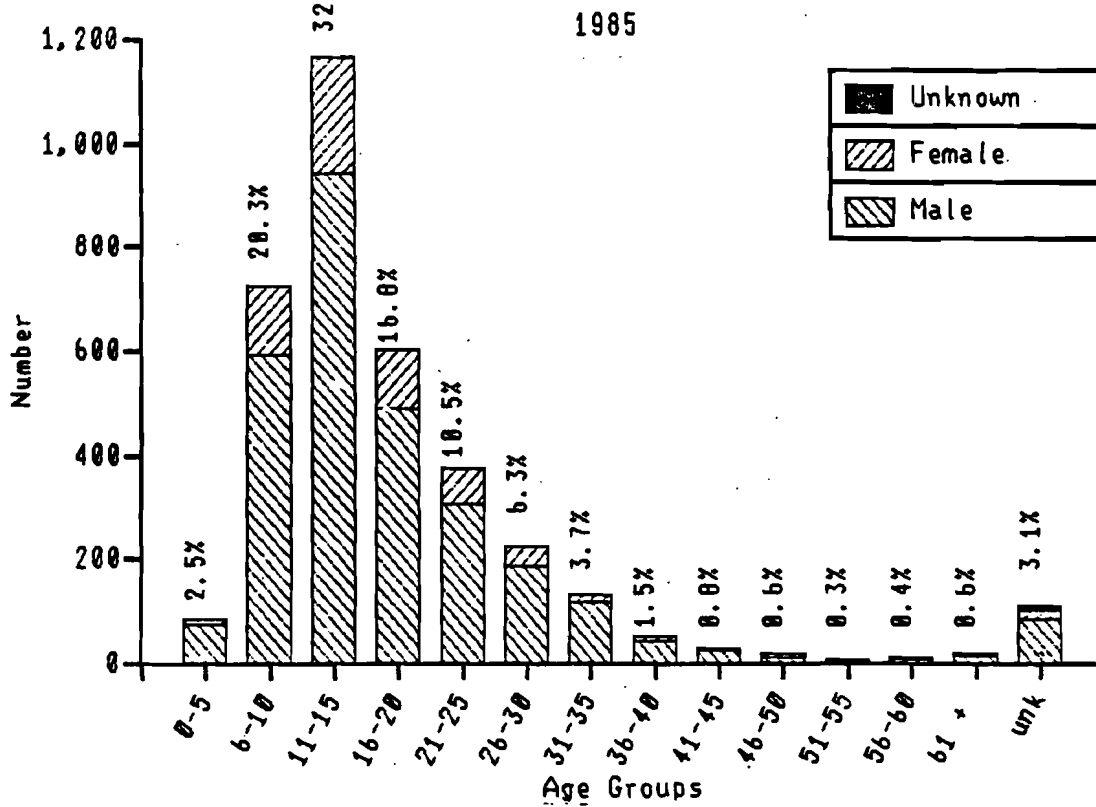

TERMS and DEFINITIONS

The following is a list of terms and definitions frequently used in this report.

Reportable Accidents — Highway accidents characterized by the following:

- a. Accidents resulting in a death within at least 90 days of the accident or injury to any persons involved.
- b. Accidents resulting in damage to any vehicle involved serious enough to demand towing.

Alcohol Related Accident — Any reportable accident in which one or more of the drivers was reported to have been drinking.

Fatal Accident — An accident in which one or more of the involved persons died within 90 days of the accident.

Injury Accident — An accident in which none of the involved were killed but at least one was injured.

Property Damaged Only Accident (PDO Accident) — A reportable accident where no one was killed or injured but damage to the vehicle required towing.

Operator — The occupant of a vehicle who is in actual physical control of a vehicle in transport or, for an out-of-control vehicle, the occupant who was in control before control was lost.

Occupant — Any person who is in or upon a vehicle, including the driver, passengers, and persons riding on the outside of the vehicle.

Passenger — Any occupant of a vehicle who is not the driver.

Pedestrian — Any person not in or upon a vehicle.

Holidays — The six major holidays are regarded as three, four, or five day holidays since the weekend is also included regardless of whether or not the holiday itself fell on the weekend. The holiday weekend begins at 6:00 P.M. of the last working day and ends at midnight on the last day of the holiday. Pre-holiday weekends and post-holiday weekends are time periods equivalent to that of the holiday occurring the weekend before or the weekend after the holiday, respectively. It is significant to look at these statistics because in many instances the number of accidents and/or fatalities (injuries) are equal to or greater than those occurring on the actual holiday weekend.

Accident Description — A description which characterizes the harmful event which caused the reportable accident and is described as one of the following:

- a. **Non-Collision** — A harmful event that does not involve a collision with a fixed object or a non-fixed object. These events include explosion, fire, overturn immersion, vehicle being struck by a flying object, etc.
- b. **Rear-End Collision** — A collision where the front end of one vehicle collides with the rear end of another vehicle.
- c. **Head-On Collision** — A collision where the front end of one vehicle collides with the front end of another vehicle while the two vehicles are travelling in opposite directions.
- e. **Sideswipe** — A collision between two vehicles in which the sides of both vehicles sustained minimal engagements.

- f. **Hit Fixed Object** — A collision in which a vehicle collides with objects attached to the terrain or stationary objects intentionally placed for a particular purpose.
- g. **Hit Pedestrian** — A collision between one or more motor vehicles and any person(s) not in or upon any of the vehicles.

Major Injury — Any injury other than fatal which by its severity requires immediate emergency transport, such as by ambulance, to a hospital or clinic for medical treatment and/or hospitalization. Major injuries would include amputation of limb(s), severe burns, etc.*

Moderate Injury — Any injury which may require some form of medical treatment but is not life threatening or incapacitating. These injuries should be visible. Moderate injuries would include a cut which requires several stitches or a broken finger or toe.*

Minor Injury — An injury which can be treated by first aid application whether at the scene of the accident or in a medical facility. Complaints of injuries which are not visible and do not appear to be of any major or moderate nature should be coded as minor injuries.*

S.U.T. — Single Unit Truck.

*As defined in the *Police Accident Report Manual*.

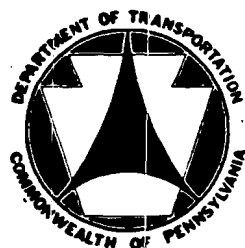

**Prepared by the
Pennsylvania Department of Transportation
For additional copies write:
Pennsylvania Department of Transportation
Center for Highway Safety
215 Transportation & Safety Building
Harrisburg, PA 17120**



Commonwealth of Pennsylvania
Robert P. Casey, Governor
Howard Yerusolim, Secretary

