

PENNDOT PROJECT INFORMATION

Rainbow Run Road
over Becketts Run
Structure Replacement
SR 136, Section A10
Forward Township,
Allegheny County



PROJECT TEAM

- Design Division
 - Direct questions to:
Cherie DiDomenico – District Project Manager at 412-429-4868
Engineering District 11-0
45 Thoms Run Road
Bridgeville PA 15017
or cdidomenic@pa.gov
 - Mark J.Young - District Environmental Planning Manager
 - Nick Krobot, P.E. – Environmental Project Manager
- Press Office
 - Steve Cowan - District Press Officer



PURPOSE OF PRESENTATION & PROJECT INTRODUCTION

- SR 136 Section A10 (Rainbow Run Road) Project
 - The purpose of this presentation is to introduce the project to the public, gather feedback, and present the proposed design.
 - The purpose of the project is to provide a sustainable crossing on SR 136 (Rainbow Run Road) over Beckets Run which meets current design standards.
 - Bridge replacement over Beckets Run



PROJECT LOCATION

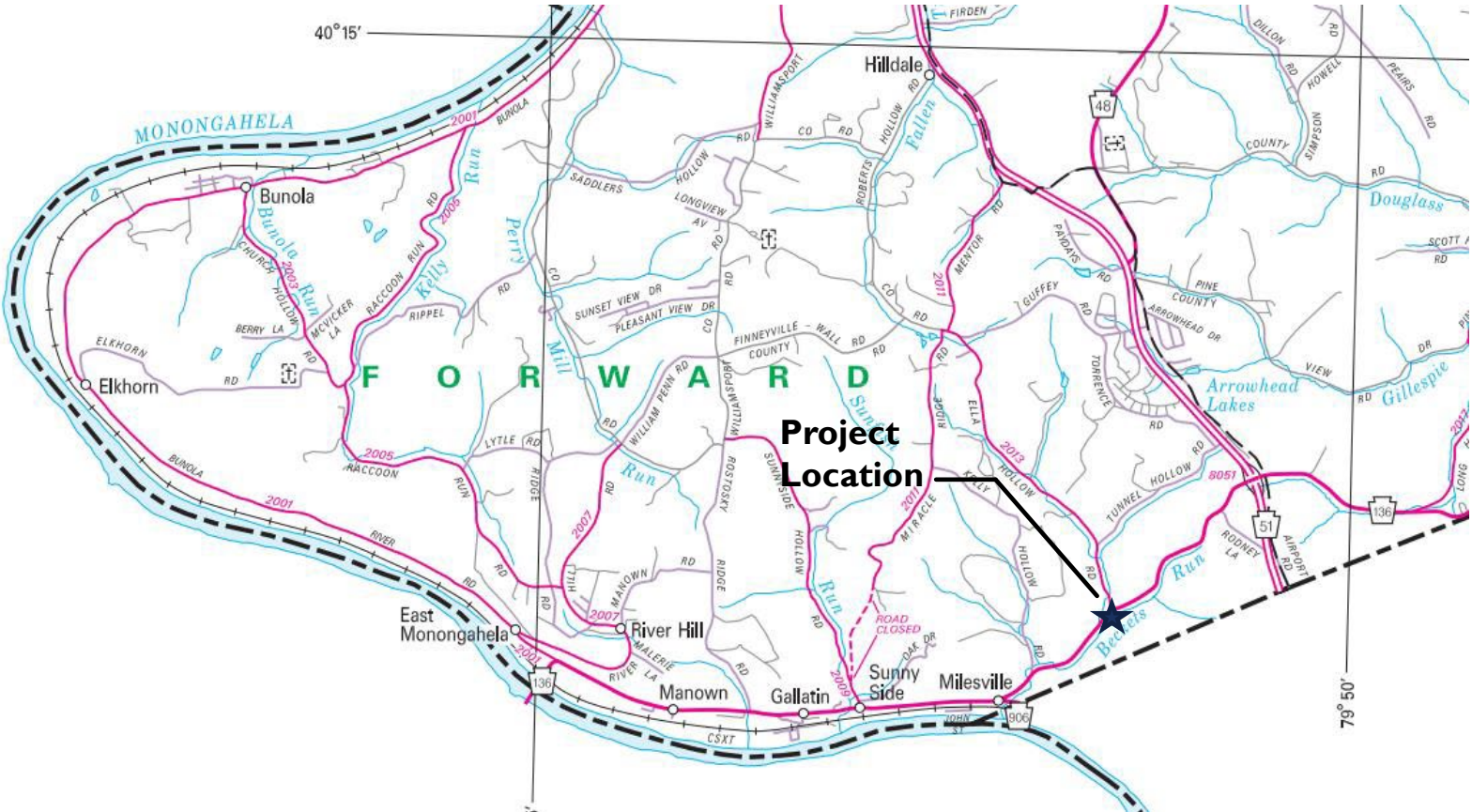

PROPOSED PROJECT IMPROVEMENTS

- Replace structure carrying SR 136 (Rainbow Run Road) over Beckets Run and upstream Retaining Wall
- Reconstruct approach roadway on both sides of the structure and improvements to Ella Hollow Road adjacent to the project area (minor paving adjustment)
- Acquisition of Right-of-Way required for re-grading around structure replacement
 - Temporary Constructions Easements also needed
- Construction anticipated to begin in 2024
 - Road will be closed and detoured during construction
 - Proposed detour is approximately 6.0 miles - Car & Bicycle, 12.5 miles for Trucks & 2.75 miles for SR 2013 (Ella Hollow Rd)



UNOFFICIAL

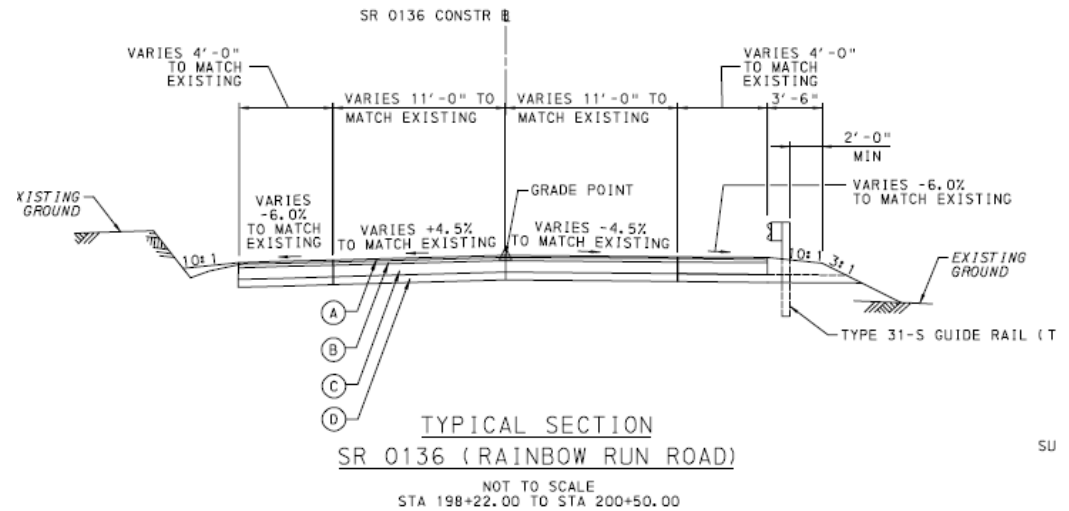
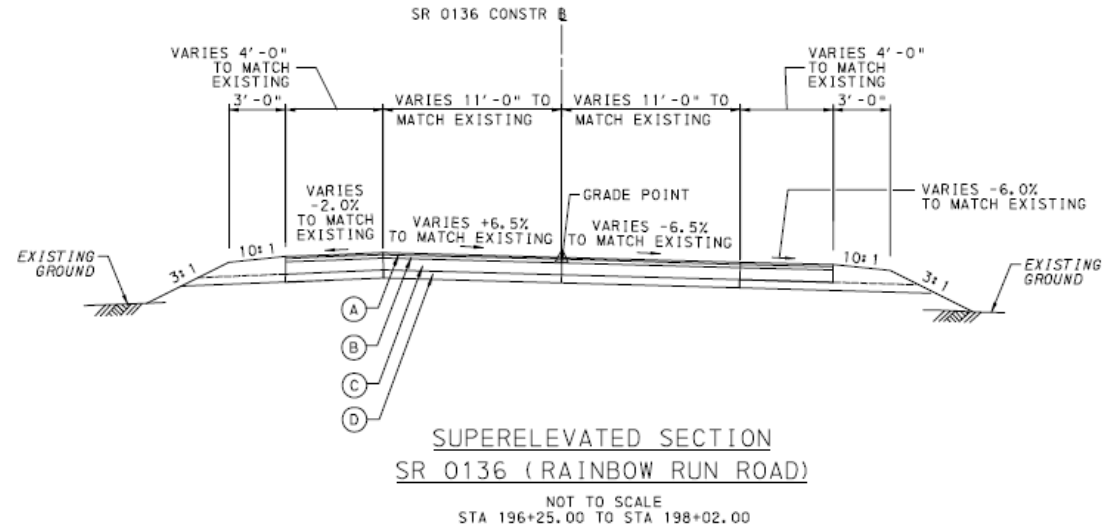
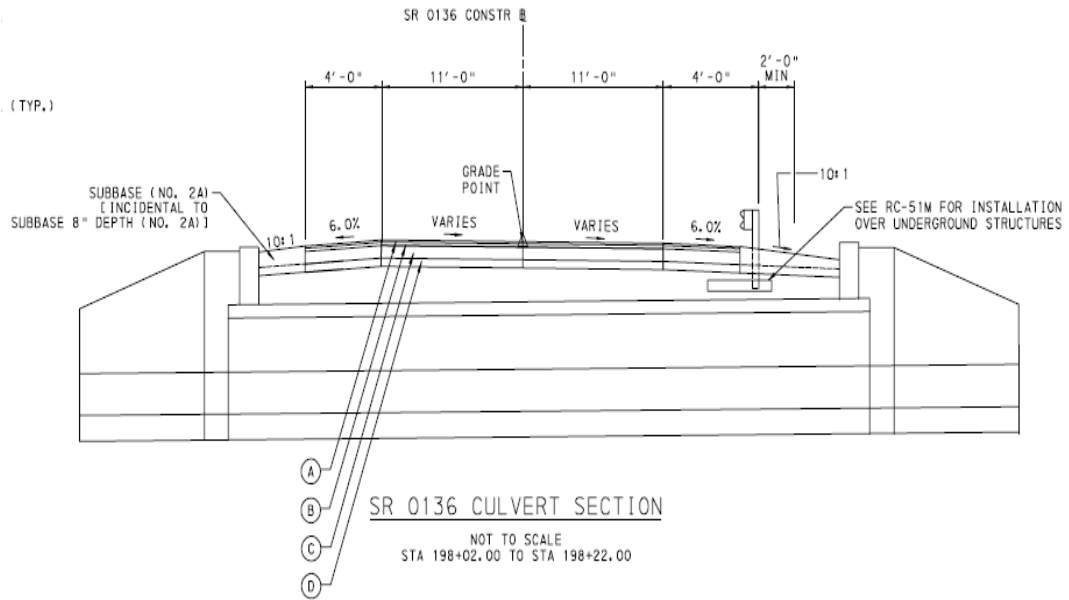

SU

Proposed Truck Detour Route

- SR 0906 SB (Webster Road) to
- SR 8062 EB to
- SR 3013 SB (C. Vance Deicas Hwy) to
- SR 0201 EB (Rostravar Road) to
- SR 0051 NB to SR 0136
- Approx. 12.5 Total Miles

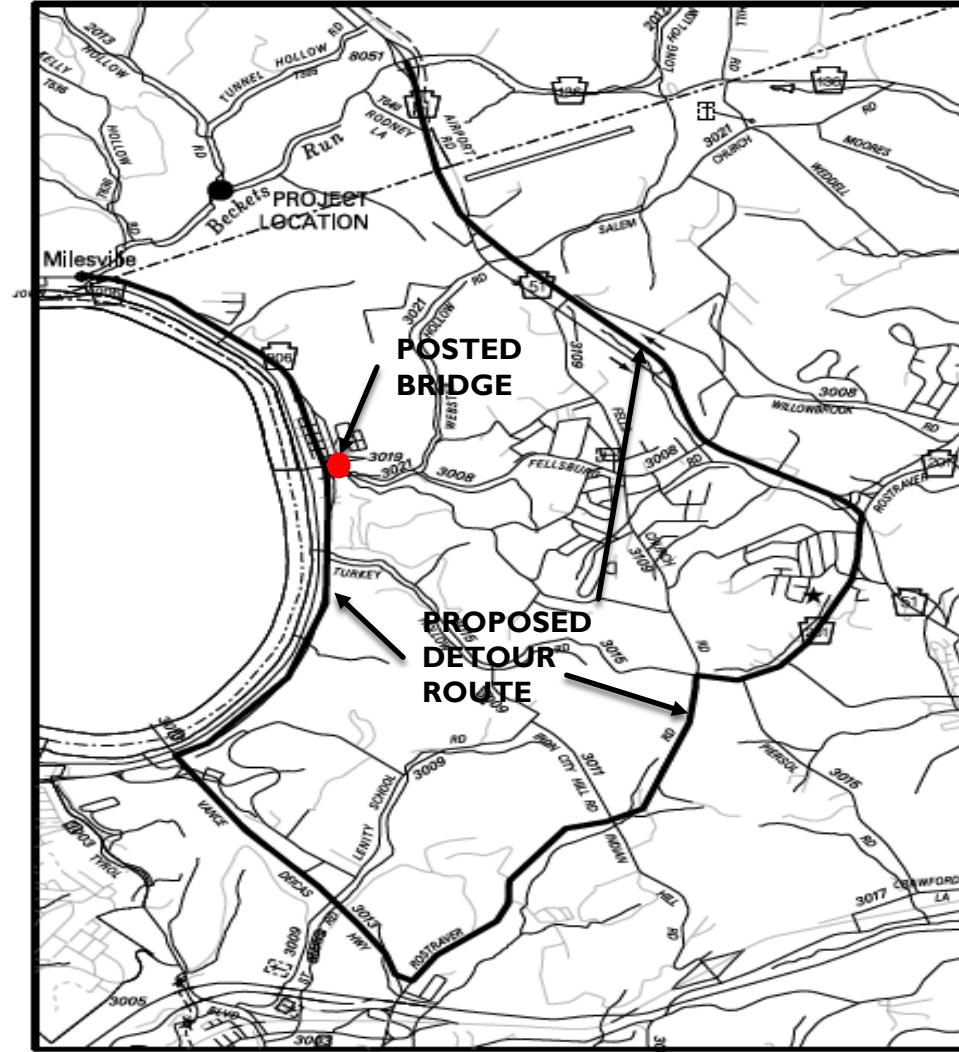

Proposed SR 136 Truck Detour

Proposed Car and Bicycle Detour Route

- SR 0906 SB (Webster Road) to
- SR 3019 NB to
- SR 3021 EB (Webster Hollow Road) to
- SR 3008 EB (Fellsburg Road) to
- SR 51 NB to
- SR 0136 (Rainbow Run Road)
- Approx. 6 miles

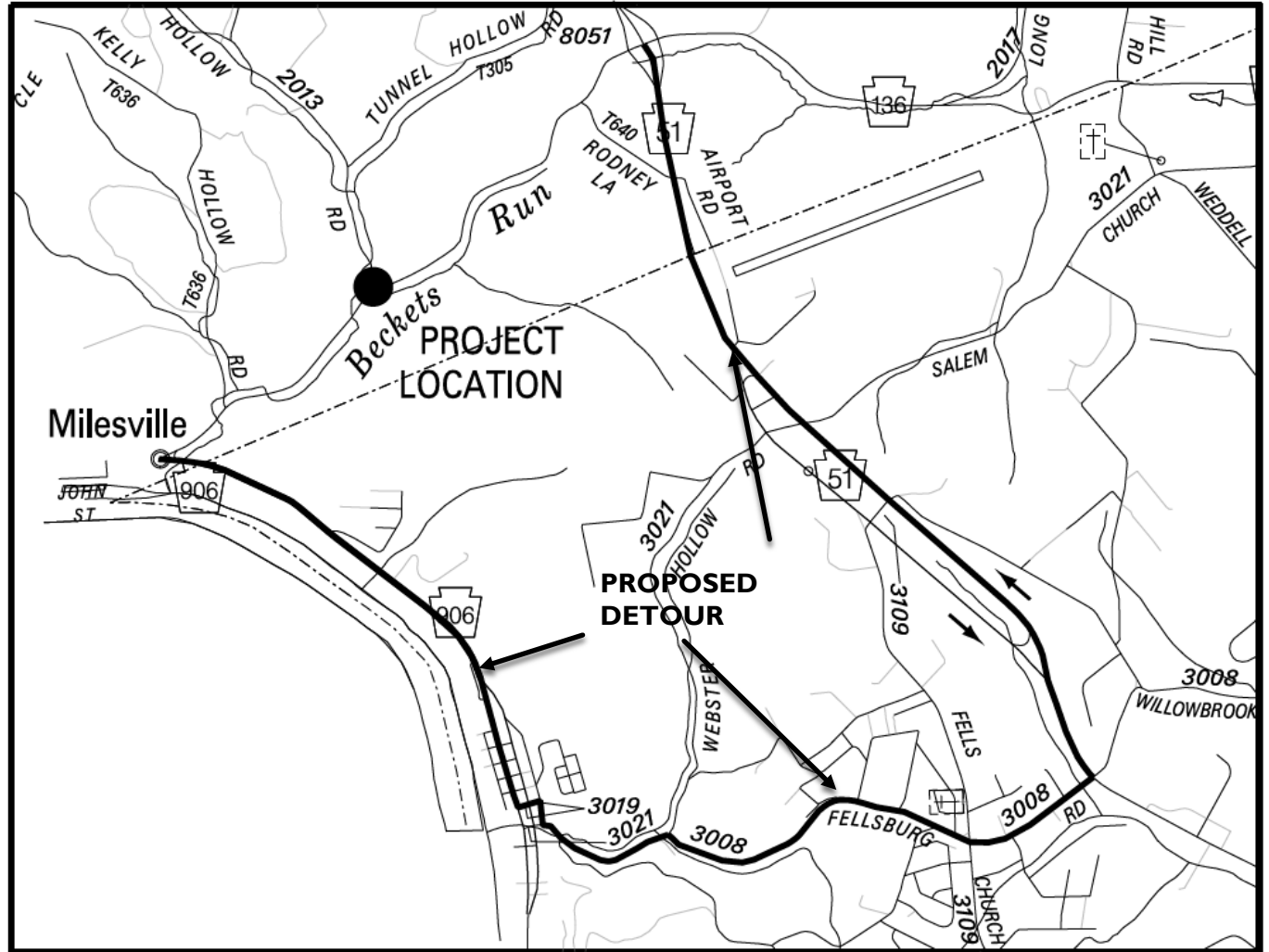

Proposed SR 136 Car and Bicycle Detour

Ella Hollow Road Detour Route

- SR 2013 NB (Ella Hollow Rd) to
- SR 2011 NB (Mentor Rd) to
- SR 51 NB/SB
- Approx. 2.75 miles

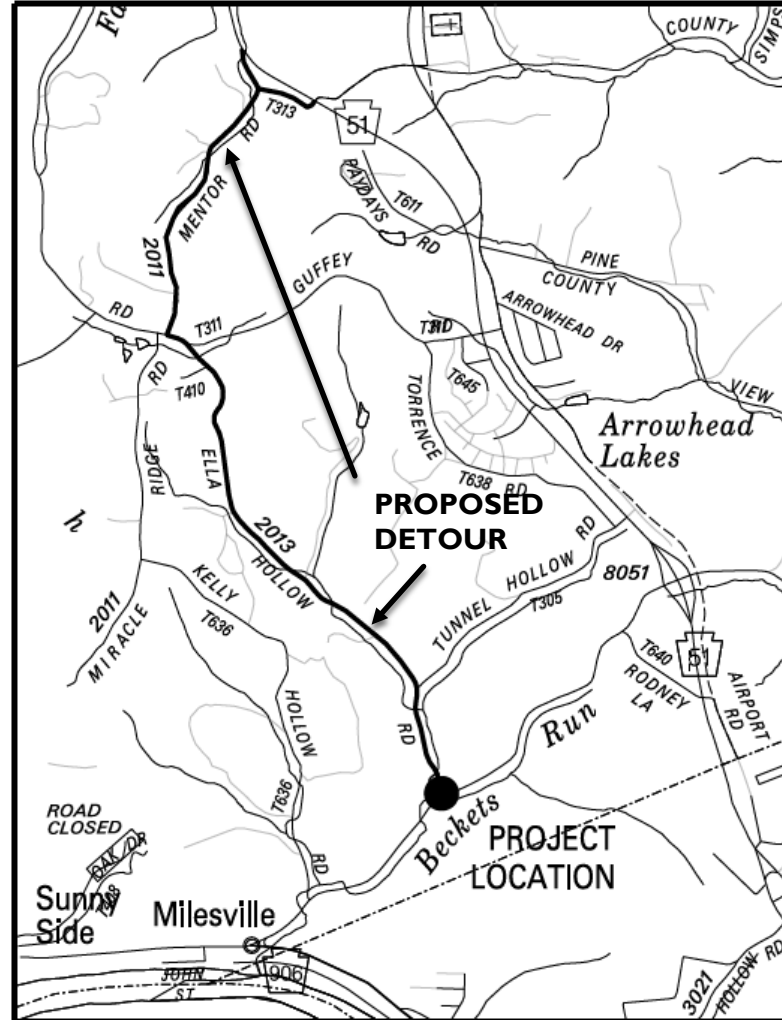

Proposed SR 2013 - Ella Hollow Road Detour

NATIONAL ENVIRONMENTAL POLICY ACT

Public outreach begins with PennDOT Connects and extends into the **NEPA** (National Environmental Policy Act) process:

- PennDOT Connects is a project planning and development approach that engages local and planning partners by collaborating with stakeholders before project scopes are developed.
- NEPA requires agencies to integrate environmental values into their decision-making processes by considering the environmental impacts of their proposed actions and reasonable alternatives to those actions
- NEPA also includes public involvement activities and gathering feedback from the public
- This PowerPoint presentation is part of District 11-0's coordination with the public to obtain feedback on the project and to meet NEPA requirements.

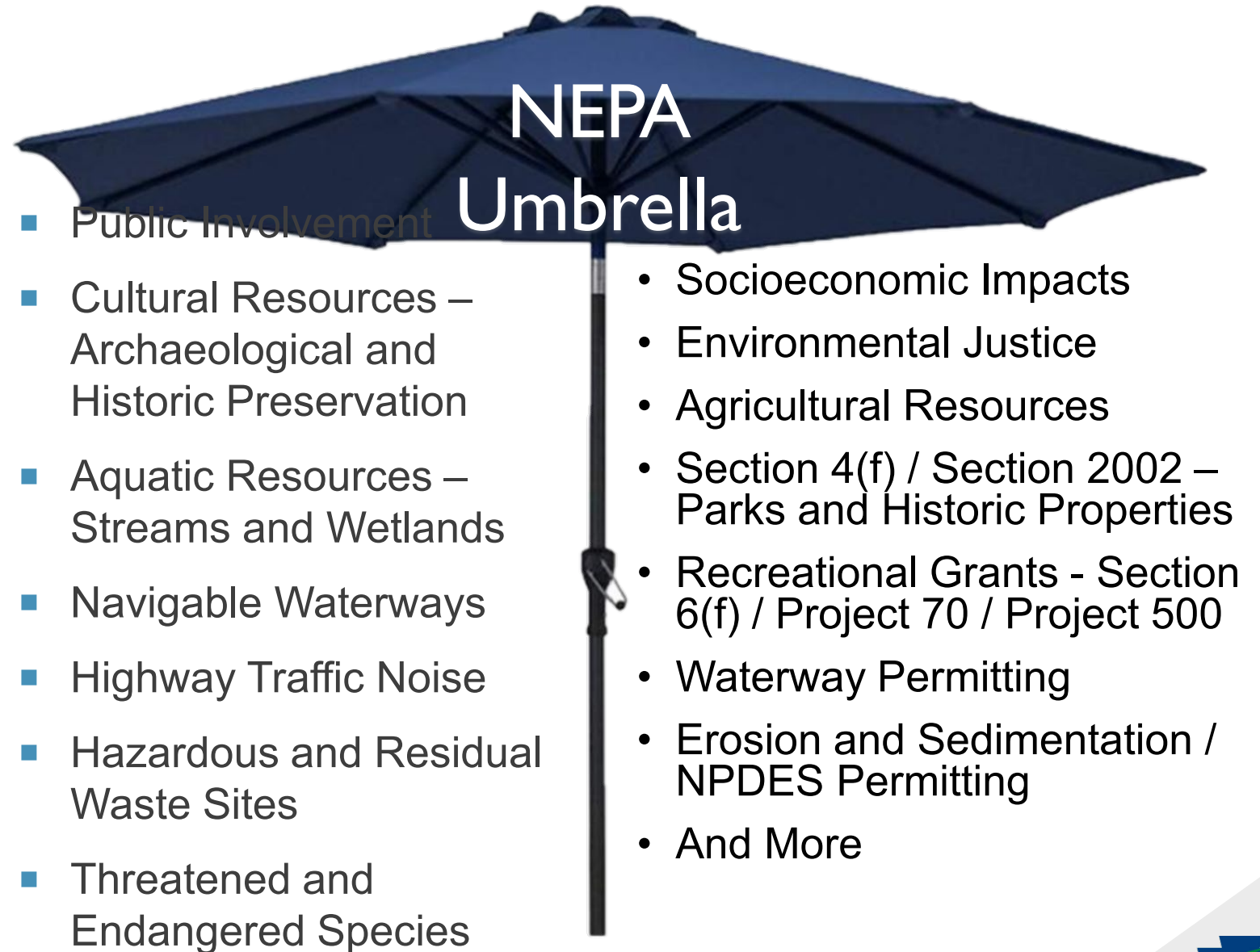

PROJECT SURVEY

PLEASE COMPLETE THE PROJECT SURVEY

- The project survey can be found on the project website.
- Click the tile under Resources labeled “Submit Comments” on the right side of the screen.

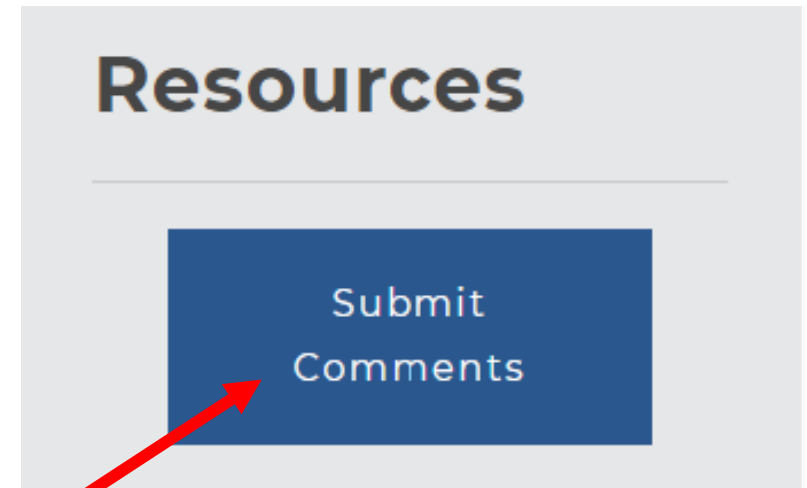

Click Here