

High Strength Tension Control (TC) Bolts

Presented by:

Joe Bracken III

High Strength Bolts for Bridges

FHWA Supplemental Contract Specifications for Projects with AASHTO M164 (ASTM A325) High-Strength Bolts

November, 1989

Specification for Structural Joints Using ASTM A325 or A490 Bolts

Research Council on
Structural Connections

AASHTO
Industrial Fasteners Institute

Pennsylvania
DEPARTMENT OF TRANSPORTATION

www.dot.state.pa.us

A325 or A490 Bolt Dimensions

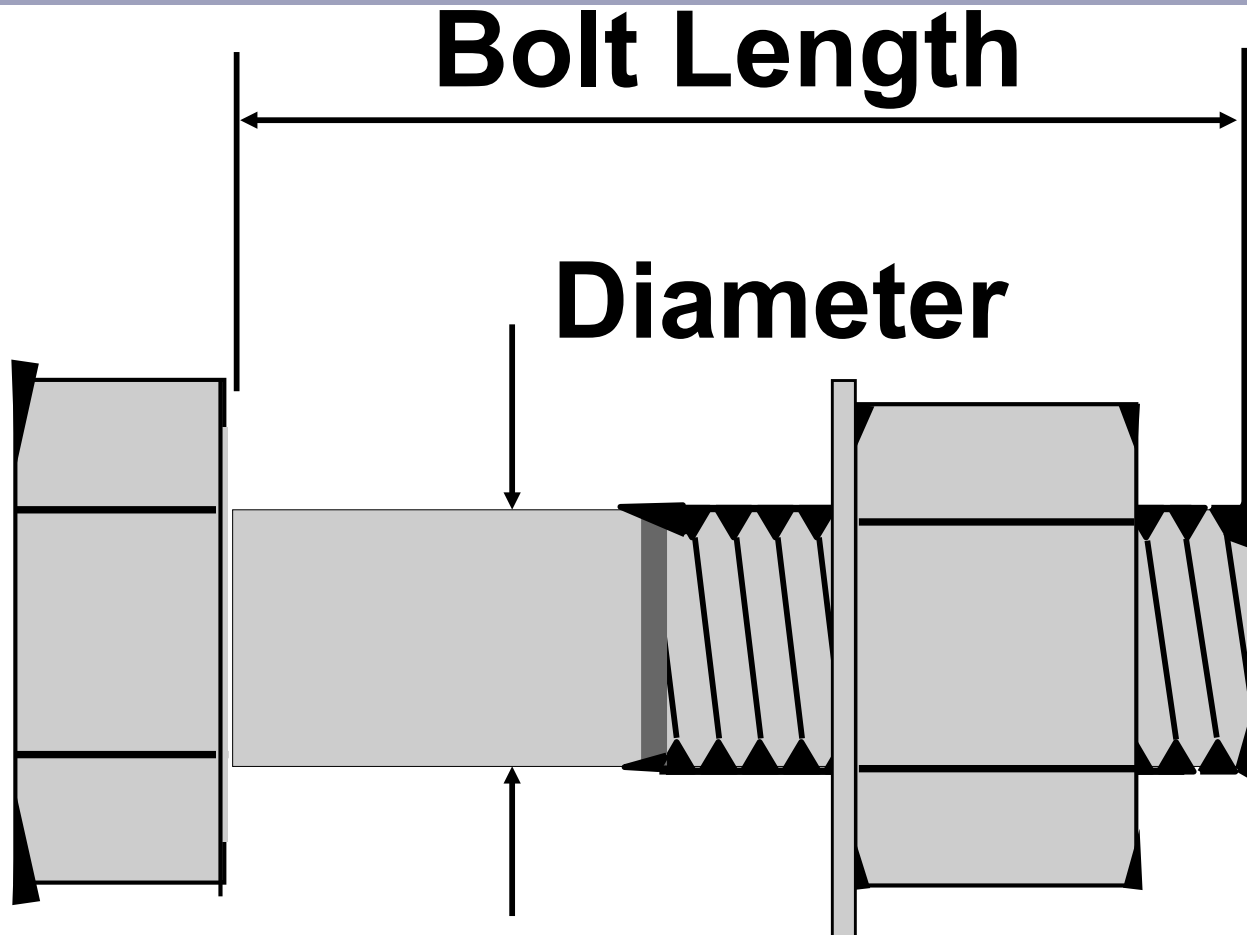

Topics

- Required Documentation
- Rotational Capacity Testing (PTM 427)
- Inspection Testing (PTM 429)
- Pre-Installation Verification Testing (Pub 408, Section 1050 and now PTM 429)
 - Turn-of-the-Nut
 - Calibrated Wrench
 - Impact Wrench
 - Manual Wrench

ASTM A563

4.8.1

Hot-dip and mechanically deposited zinc-coated Grade DH nuts shall be provided with an additional lubricant which shall be **clean and dry to the touch.**

ASTM F436

HARDENED WASHER

- REQUIRED FOR RC TEST
- REQUIRED IF OUTER FACE OF BOLTED PART HAS A SLOPE GREATER THAN 1:20
- MINIMUM THICKNESS 5/16 INCH

**Specification for
Structural Joints Using
ASTM F3125 Grades**

**A325-A1852
or A490-A2880
Bolts**

**Research Council on
Structural Connections**

AASHTO

Industrial Fasteners Institute

Pennsylvania
DEPARTMENT OF TRANSPORTATION

A1852 or A2880 Twist-Off Bolt Method

Button Head

Bolt Length

Diameter

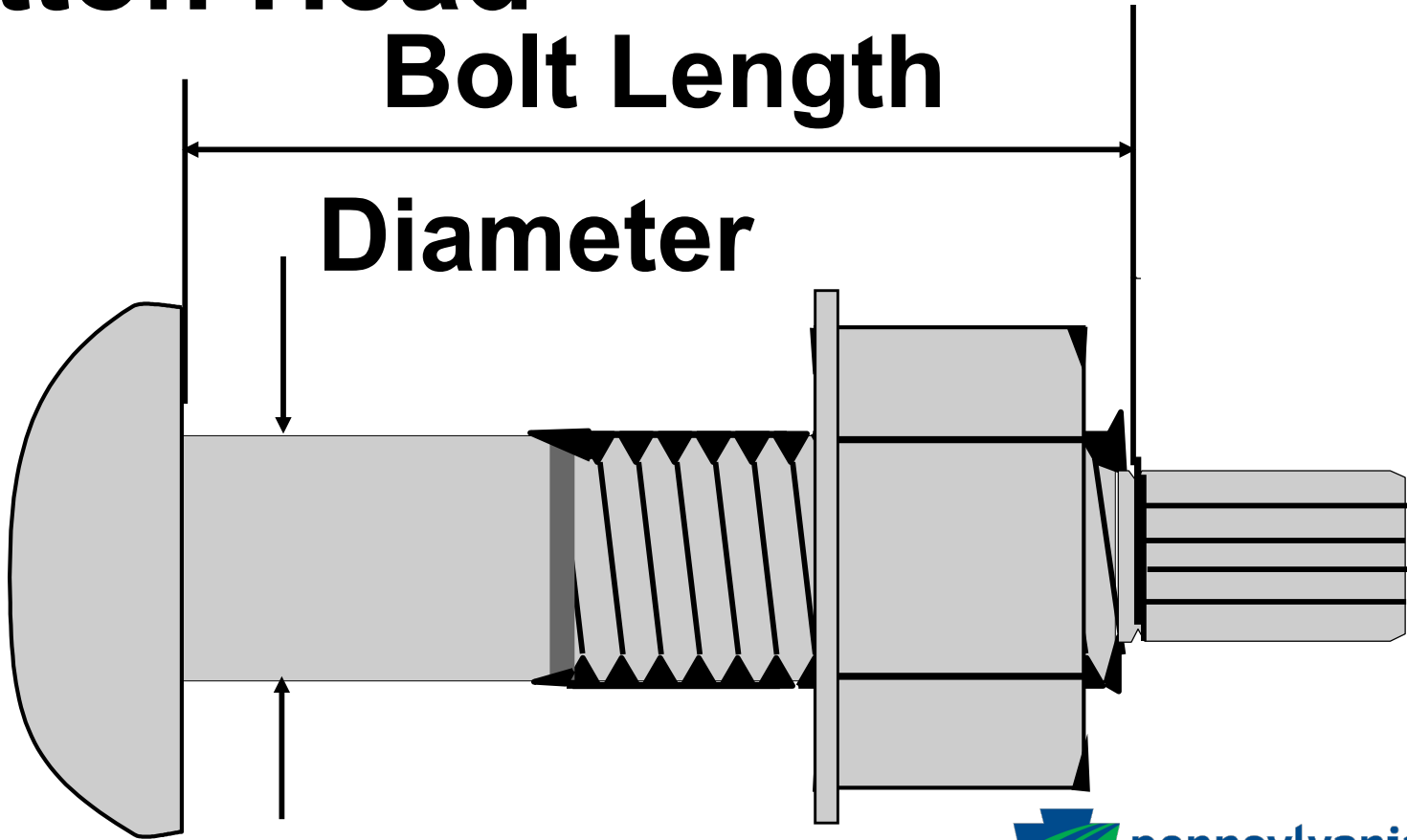

High Strength Tension Control (TC) Bolts

Tension Control (TC) Bolt

Snug bolt

Tighten to spline break

Verify tension is correct

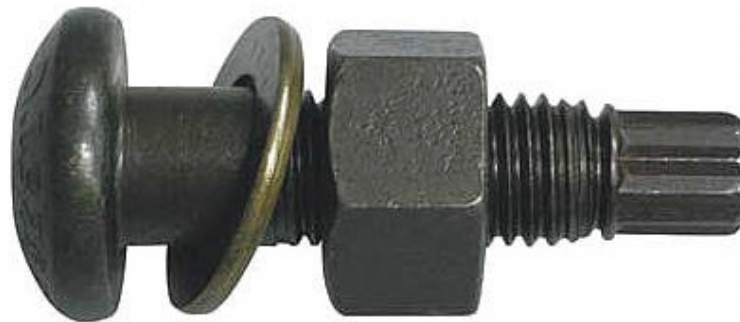

High Strength Tension Control (TC) Bolts

- TC Bolts have their own built in torque control device and are installed without the use of torque controlled tools. The torque requirements of the bolts are achieved by engaging the bolt and nut with inner and outer sockets and drive with the electric shear wrench until the control groove shears of the spline. Strength Bolt Testing

High Strength Tension Control (TC) Bolts

- Advantages:
 - 1. Proper bolt tension can be confirmed by the shear-off spline.
 - 2. Visual Inspection – (No torque gauges required.)
 - 3. No special expertise required for installation.
 - 4. Wrench adjustment not required
 - 5. Installation can be achieved by one operator on one side of the structure.
 - 6. Substantial reduction in installation noise.
 - 7. Overall cost savings as a result of reduction of labor and time

A1852
or A2880

A325 TC

A490 TC

Type
1



lines optional



Type 2



3 @ 60

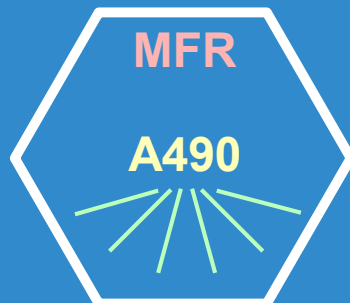

6 @ 30

Type 3



Shipping and receipt inspection

Verify:

- Identity of contents
- Inclusion of MTR/MCTR and/or DCTR as appropriate

Assembly and Use Problems

Bolts and nuts in rusty or dirty condition

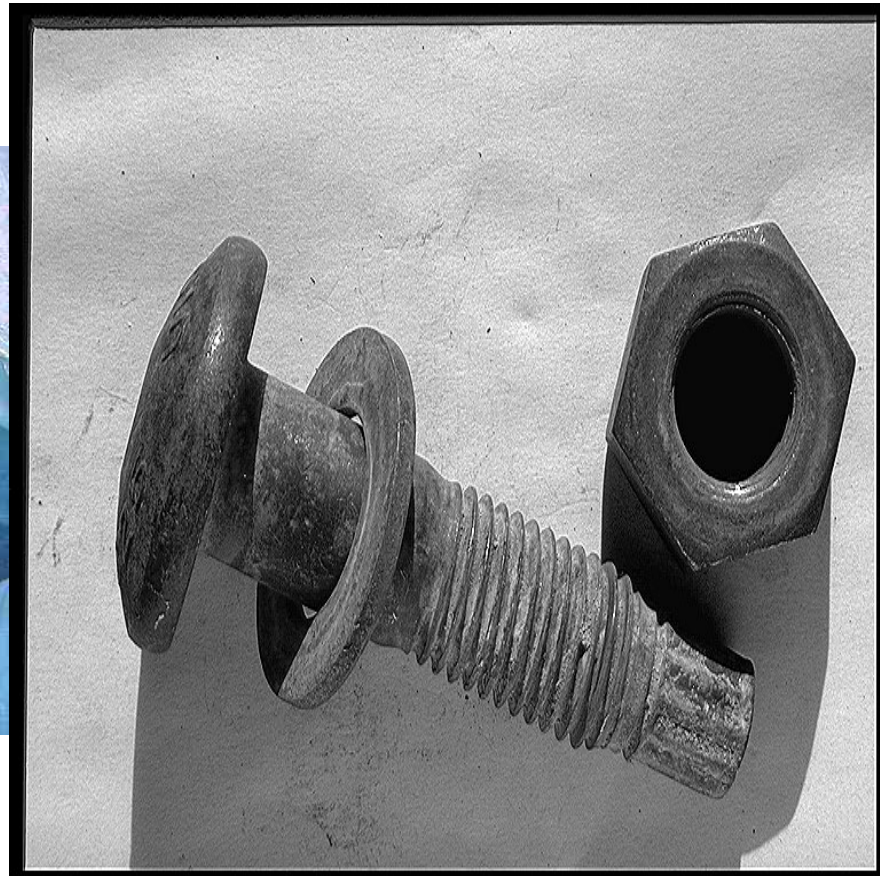

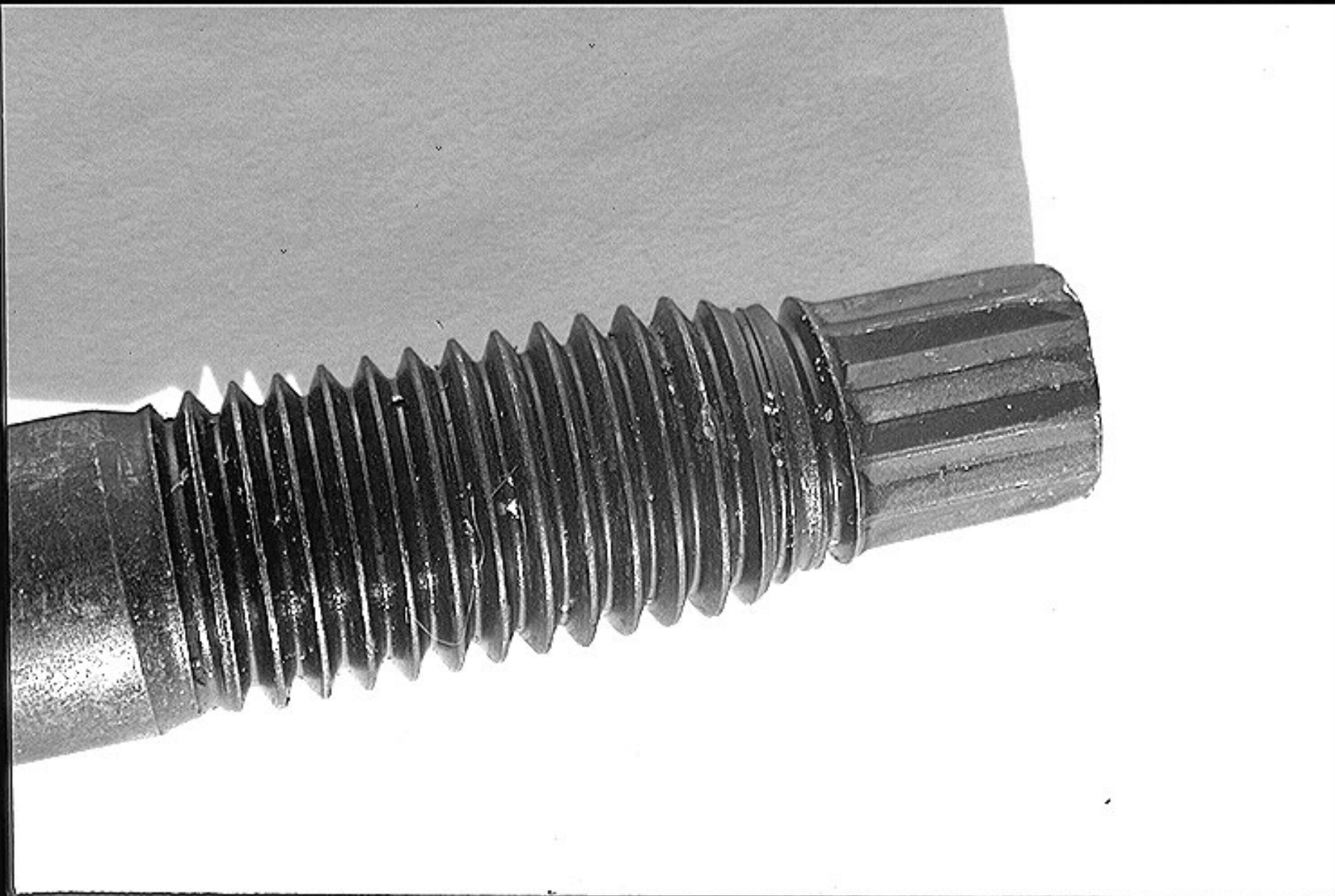



High Strength Tension Control (TC) Bolts

- Installation Procedures:
 - 1. Place bolt thru hole in properly aligned joining members
 - 2. Attach washer and snug tighten all assemblies in the joint
 - 3. Fit the inner socket firmly over the bolt's spline
 - 4. Engage the outer socket of the wrench over the nut
 - 5. Pull the trigger. The outer socket will rotate the nut until the torque control groove shears off the spline, thereby achieving proper bolt tension
 - 6. Remove the wrench and push the spline ejection trigger to remove the spline from the wrench's socket

High Strength Tension Control (TC) Bolts

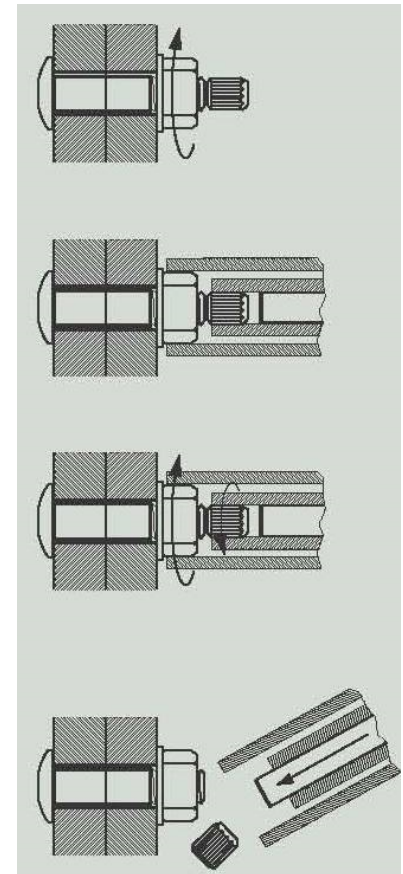

High Strength Tension Control (TC) Bolts

- **IMPORTANT TIPS ON: Handling – Storage – Installation**
 1. All structural fasteners should be protected from dirt, moisture and sun light at the job site. No more than the amount of bolts to be used that day should be removed from the container in a protected storage area. Dirty, rusted, or dry bolts should not be used.
 2. Place all bolts into the connection, with a washer under the nut in standard and short slotted holes. For long slotted and oversize holes, a washer should be placed under the head of the bolt and under the nut. Washer and nut identification markings should always face away from the connection.
 3. Bring all fasteners in the connection into a snug tight condition, starting from the most ridged part of the connection.

High Strength Tension Control (TC) Bolts

- Staying Out of Trouble at the Job Site
- Tips & Problem Solving Solutions
- Verify Bolt Tension on the Job Site

High Strength Tension Control (TC) Bolts

Staying Out of Trouble at the Job Site

- 1. Review the basic bolt calibrator set up as described for bolt tension calibrator such as a Skidmore Wilhelm.
- 2. Be sure that unit is calibrated and that it is set up with the correct diameter bushings.
- 3. Use hardened spacers for longer bolts, DO NOT stack multiple flat washers.
- 4. Review the instructions for use of the testing device
- 5. Only use bolts from fresh, unopened bolts for testing

High Strength Tension Control (TC) Bolts

Tips & Problem Solving Solutions

- Installation Problems
 - Q: A bolt breaks in the threaded portion before the spline shears off?
 - Answer: Mostly likely the torque co-efficiency value has decreased.

High Strength Tension Control (TC) Bolts

- Possible Causes

- 1. Storage conditions allowing moisture, exposure to rain, high humidity, temperatures over 140 degrees
- 2. Lubrication of the product beyond “as delivered” condition from the factory. (Use of oil, grease or wax on the product components at the job site is prohibited.)
- 3. Adhesion of oils, paints, mill scale, dirty burrs or foreign material on the faying surfaces which may allow rotation of the bolt or rotation of the washer with the nut during tightening operation.
- 4. Not properly bringing the connection to the snug tight condition before final wrench tightening which may allow for the bolt to rotate, same as hex bolts.
- 5. Possible misalignment of the connection members that may prevent proper contact of the bolt head and faying surface.
- 6. Exposure to the environment over an extended time period before final tightening.

High Strength Tension Control (TC) Bolts

Tips & Problem Solving Solutions

- Q: Spline breaks at the shear groove before joint connection is made or before specified fastener tension is achieved in bolt tension testing device? Answer: Mostly likely the torque co-efficiency value has become higher.
Possible Causes:
 - 1. Storage and handling conditions allowing sand, dirt, rust or other foreign material to accumulate on the threads of the bolt or nut.
 - 2. Rough handling of the fasteners that would cause nicks or gouges on the bolt and nut.
 - 3. Exposure to environmental conditions that cause rust to form on the threads of the bolt nut or washer face.
 - 4. Failure to follow AISC procedures for initial tightening in bringing all plies of the joint into firm contact before final tightening. (i.e. trying to draw distorted plies together and shearing the spline before the plies are in contact instead of using "fit up" bolts.) On a TC bolt, the spline will shear off when too great of a torque force is applied. Whereas a hex bolt may be torqued beyond the plastic limit of the bolt without the knowledge of together.

High Strength Tension Control (TC) Bolts

Staying Out of Trouble at the Job Site

- 1. Storage and handling conditions allowing sand, dirt, rust or other foreign material to accumulate on the threads of the bolt or nut.
- 2. Rough handling of the fasteners that would cause nicks or gouges on the bolt and nut.
- 3. Exposure to environmental conditions that cause rust to form on the threads of the bolt nut or washer face.
- 4. Failure to follow AISC procedures for initial tightening in bringing all plies of the joint into firm contact before final tightening. (i.e. trying to draw distorted plies together and shearing the spline before the plies are in contact instead of using "fit up" bolts.) On a TC bolt, the spline will shear off when too great of a torque force is applied. Whereas a hex bolt may be torqued beyond the plastic limit of the bolt without the knowledge of together

High Strength Tension Control (TC) Bolts

Wrench Problems Spline does not eject from socket

- 1. Check inner socket for abrasions or upsets. Remove replace socket.
- 2. Check inner socket for rust, sand, dirt oil or other foreign material caused by poor handling or care in the field. Clean inner socket and replace if necessary.
- 3. Check bolt spline foreign as a result of poor handling in the field.
- 4. Check ejector spring for contamination, clean components if necessary. Replace spring and pin if broken or worn.
- 5. Check sockets for wear and replace if necessary..

High Strength Tension Control (TC) Bolts

Socket does not engage properly with spline or nut

1. Check serrations of the socket for wear and replace if necessary.
2. Check socket size to be sure it matches the fastener being used.

High Strength Tension Control (TC) Bolts

Tension Control (TC) Bolt

Snug bolt

Tighten to spline break

Verify tension is correct

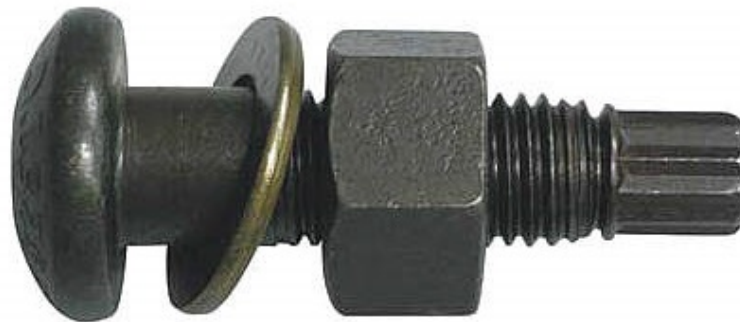

Summary High Strength Tension Control (TC) Bolts

Principle

Fasteners and tooling

Installation method

Long bolt installation verification

Short bolt installation verification

Twist-Off Bolt Method

Installation method

Snug joint

Use systematic approach

**Tighten until twist-off,
following manufacturer's
instructions**

Quality Assurance Program For Bridge Fabrication

- I AM WATCHING YOU

MAKE ME HAPPY



PennDOT's Quality Assurance Program For Bridge Fabrication

ALL OF YOU ARE... the Link to Quality

Questions?

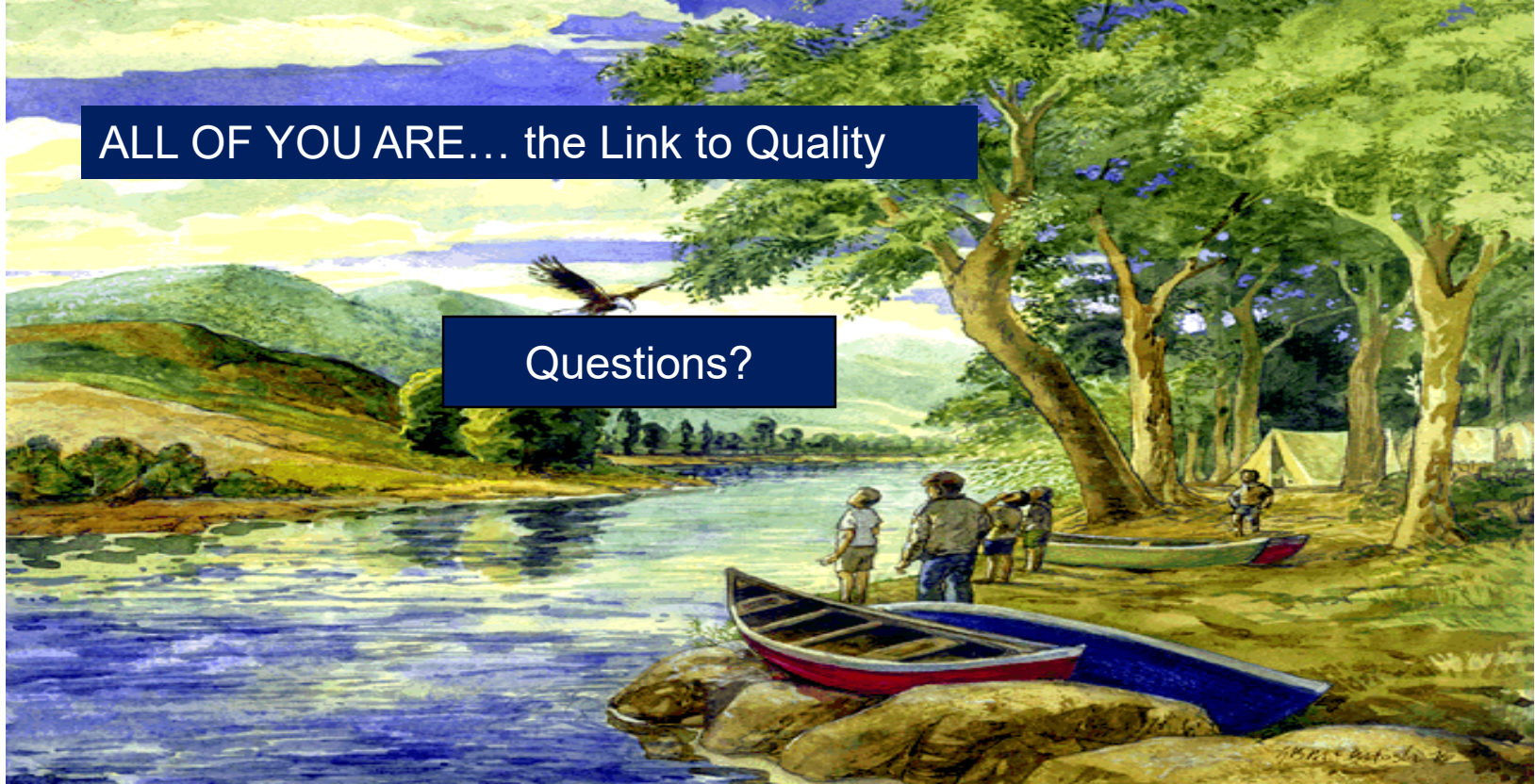

Direct Tension Indicator Method

F959

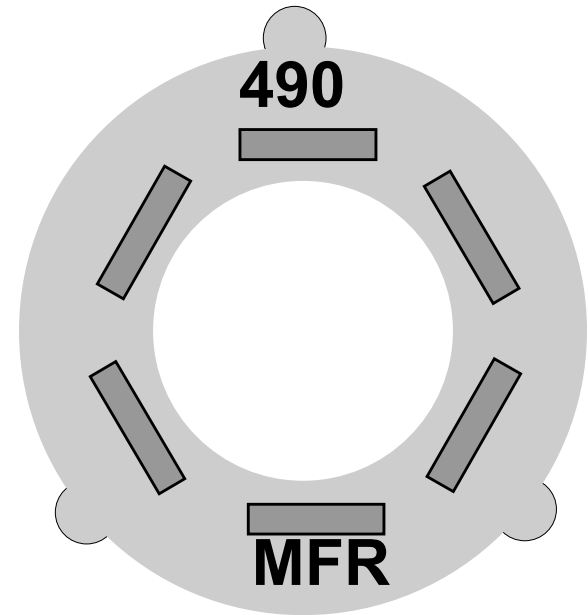
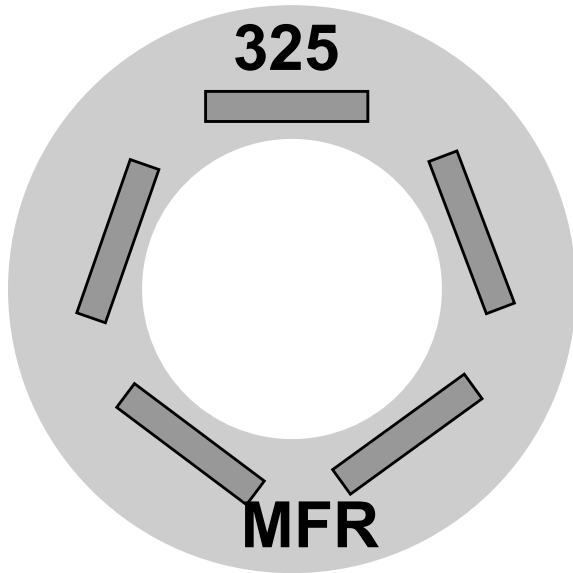

3/4"

Direct Tension Indicator Method

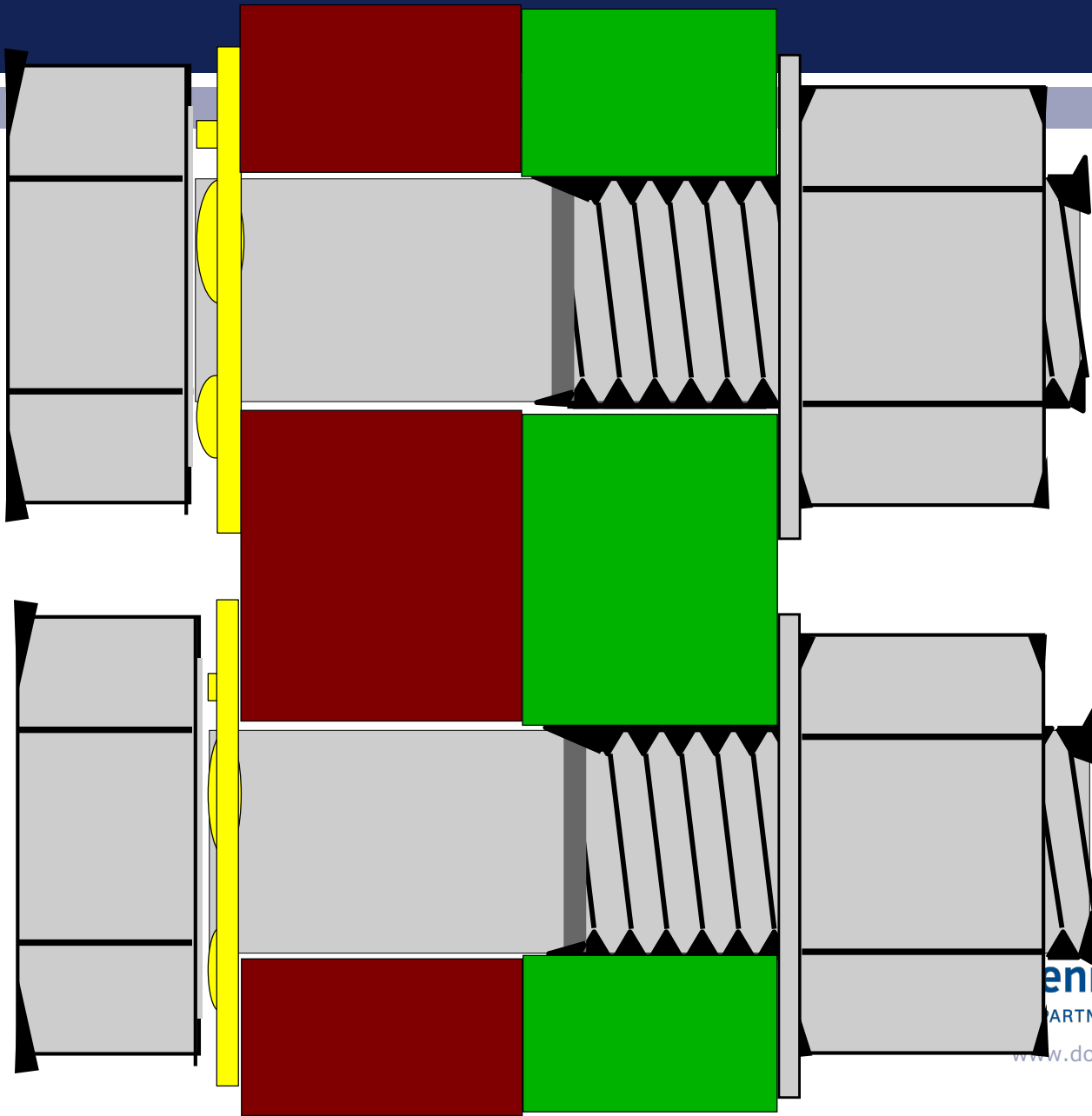

Direct Tension Indicator Method

hold
head

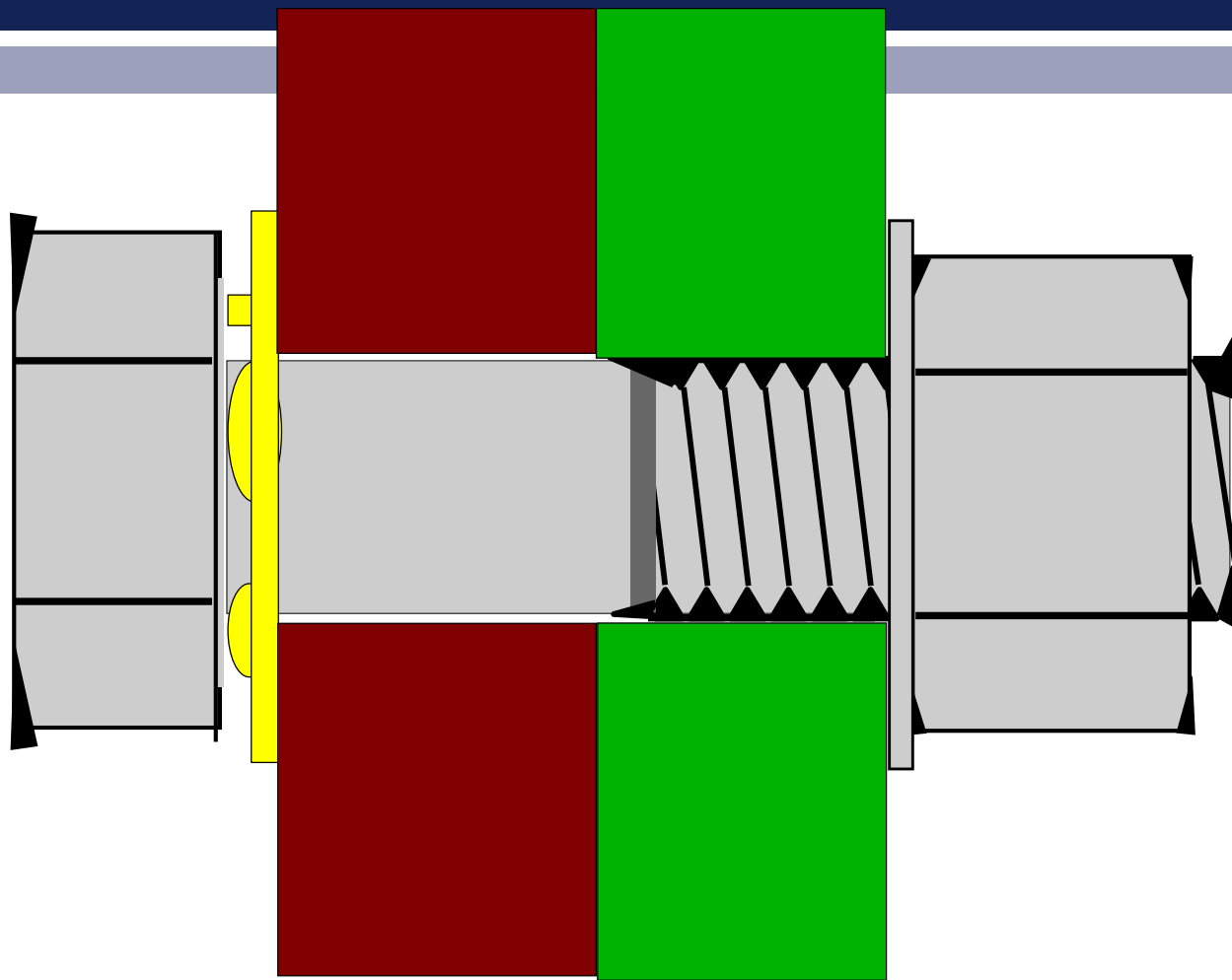

Direct Tension Indicator Method

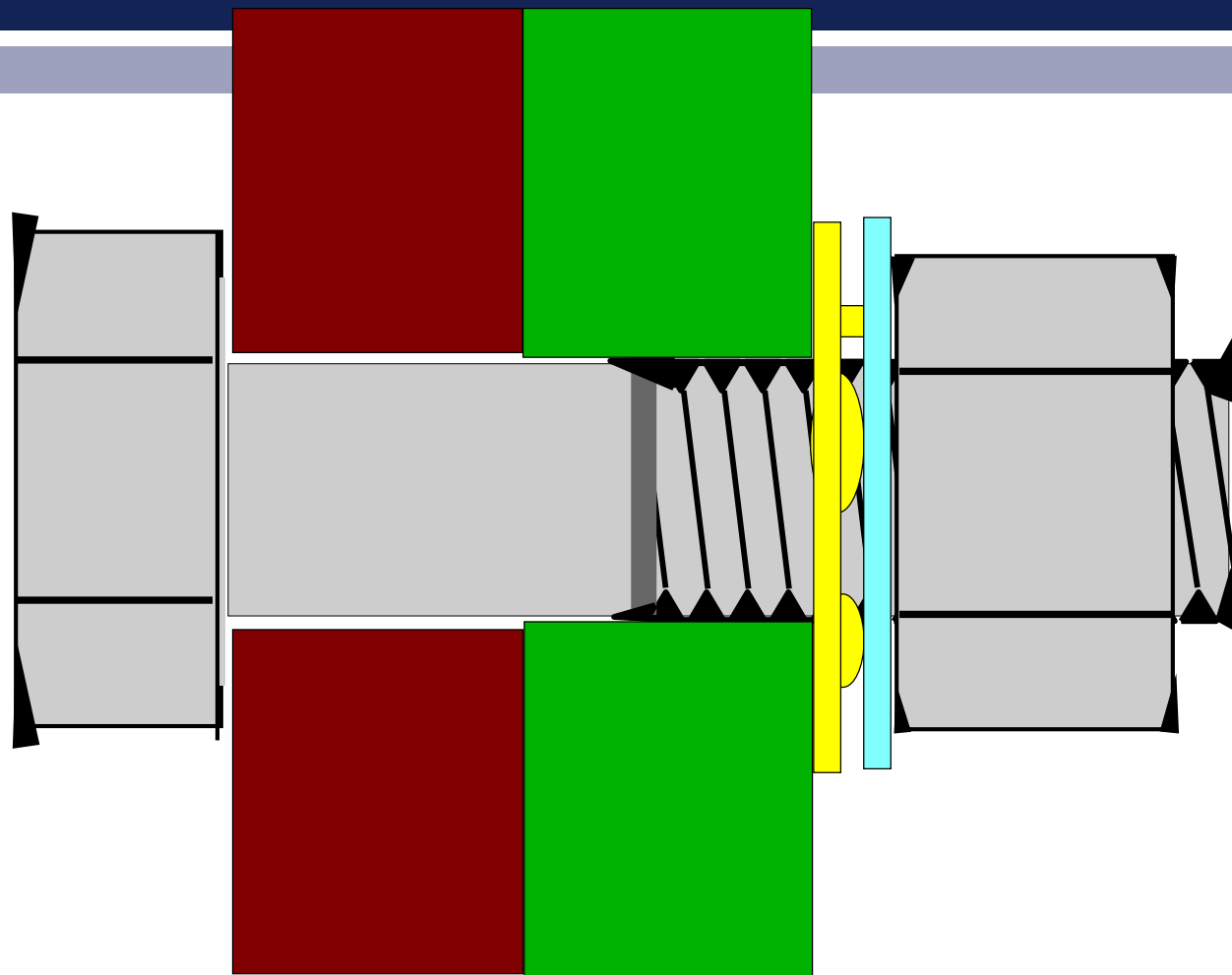

Direct Tension Indicator Method

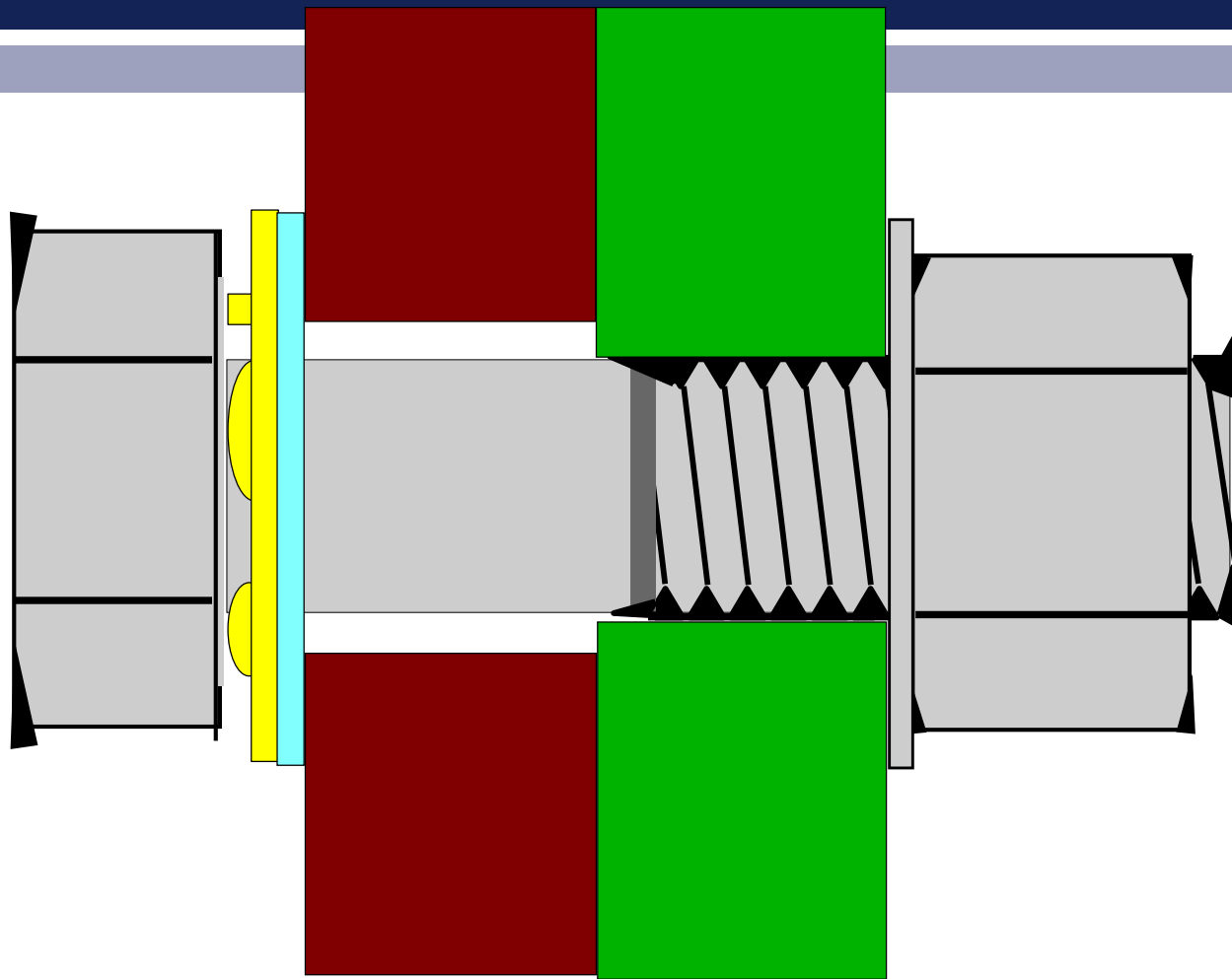

Direct Tension Indicator Method

