

Quality to Achieve a 100-year Design Life: a focus on Service Life

53rd Mid-Atlantic Quality Assurance Workshop
Williamsburg, Virginia
February 13, 2020

Michael C. Brown, PhD, PE

US Bridge Asset Management Lead

Senior Technical Principal



Overview

- *Design Life* concepts
- Influences and limitations on design/service life
- Approaches to Service Life Design
 - *Environment*
 - *Deterioration Mechanisms*
 - *Design Strategies*
- Implementation and the Role of Quality Assurance
- Some simple examples/lessons learned

Concepts related to *Design Life*



Sustainability and Durability

Sustainability - avoiding the depletion of natural resources; meeting current needs without compromising the ability to meet future needs.

— *economic, environmental, and social*

Durability - ability of a physical product to remain functional, without requiring excessive maintenance or repair, when faced with the challenges of normal operation over its design lifetime.

Service Life and Design Life

Service Life

The period of time that a structure is expected to be in operation, over which a structure is intended to perform its function without major repair

Design Life

Period of time on which the statistical derivation of transient loads is based (AASHTO LRFD)

Codes usually define design life that implies a particular service life regarded by society as acceptable

Code-based design life values are based on general understandings of structural behavior and reliability, material performance and construction quality



Service Life and Design Life

Design life, specific or implied, is used to guide design and construction, often by defining *limit states*

Service LS, Ultimate LS, ...and now *Durability LS*

5 ***Caveat Emptor*** - No guarantee that simply following standards ensures the implied design life will be achieved without maintenance or rehabilitation over the life of the structure

Once the design life is reached, structures are not automatically replaced or decommissioned; many stay in service for much longer.

Design for Service Life

Service life design considers:

- initial cost of creating the structure
- expected service life of system and components
- long-term cost of maintaining and repairing
- replacement cost

"Long design life" does not mean "maintenance-free"

What influences Service Life?

Ability to achieve a target *Design Life* is influenced by:

- *Type*
- *Source*
- *Handling*
- *Design details*
- *Fabrication*
- *Maintenance*



Limitations in Service Life Design

Doing what we can with what we have

Inherent risks

- Longer target design life often requires that we extrapolate what we know
- We use materials to achieve longer lives than our current experience with those materials
- We use models to project periods that are orders of magnitude greater than the underlying research used to establish the models

How does one approach Service Life Design

Design process for addressing durability:

1. Define the characteristics of the **environment**
2. Identify the potential **deterioration mechanisms** in that environment
3. Determine the likely **rate of deterioration**
4. Assess the **material life**
5. Define the material **performance requirements**
6. Take a **probabilistic approach** to the variability of the relevant parameters
7. **Assess** and define the need for further protection

Understand the environment

For structure as a whole, the **macro -environment**

— Structural Loads

— *Magnitude, type and timing of permanent loads*

— *Magnitude and frequency of transient loads*

— Exposure Zones

— *Rural/Mild/Nonaggressive*

— *Industrial/Moderate*

— *Marine*

— *Deicing*

— *Buried*



Understand the environment

Micro environment

- Buried zone
- Submerged zone
- Tidal zone/Water Level zone
- Direct deicing Salts zone
- Indirect Deicing Salts zone
- Atmospheric zone
- Interior
- Other Exterior

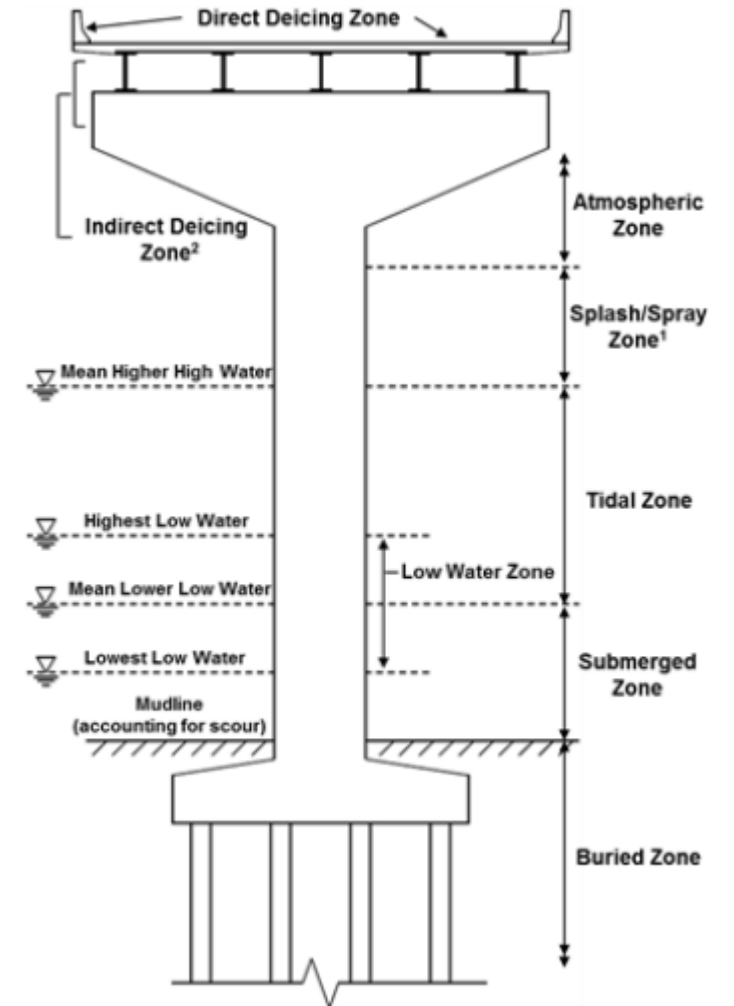

Source: from NCHRP Web-Only Document 269 (2019)

Deterioration Mechanisms

Reinforced Concrete

- reinforcement corrosion
 - *chloride*
 - *carbonation*,
- sulfate attack
- microbiological attack
- alkali-aggregate reaction
- thermal cracking
- freezing-and-thawing

Structural Steel

- Corrosion
- Fatigue
 - *Residual weld stresses*

High -strength steel wire (prestressing/post -tensioning)

- Corrosion
 - *Chloride*
 - *Carbonation -induced*
 - *Concentration gradients
(e.g., pH, voids in grout)*
 - *Stress-corrosion*
- Hydrogen embrittlement

Polymer composites

- UV degradation/chalking
- Moisture uptake
- Oxidation/embrittlement

Strategies to Design for Service Life

Provide means for structure to withstand environment and loads without reaching limit states during the target service life, by:

- selecting/specifying **materials** with sufficient durability to withstand deterioration through the design service life
- providing **protective systems** (e.g. reinforcement coating, membranes, overlays, steel coatings, joints, and scuppers)
- providing **dimensions and details** to reduce the rate of deterioration (e.g. cover dimension, reinforcement size, and reinforcement spacing)
- specifying **shorter service life for specific elements** and planning for their replacement (e.g. joints, bearings, scuppers, and traffic barriers)

Remove vulnerability of a structure to deterioration

Service Life Design

Design Approaches

- Full Probabilistic
- Partial factor
- Deemed-to-satisfy
- Avoidance

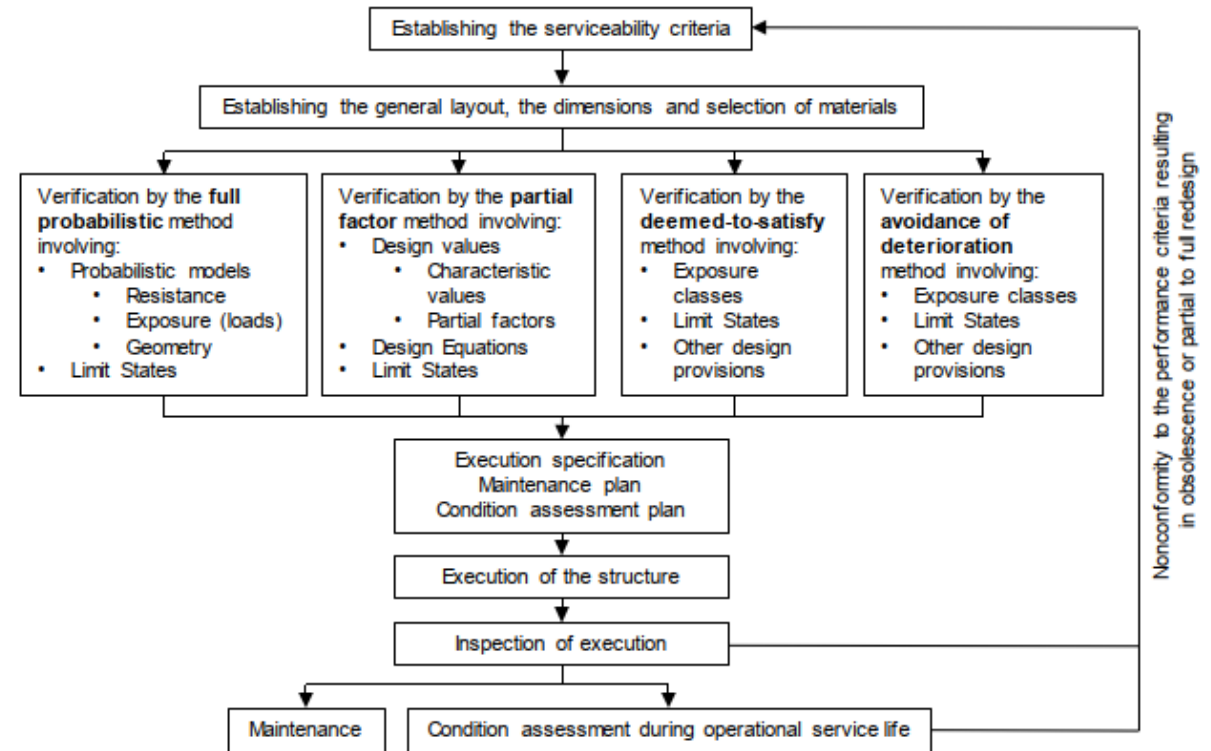

Source: adapted from ISO (2012)

Service Life Design

Full probabilistic method – reliability indices of specific limit states are explicitly computed during the design process using deterioration models

Full Probabilistic Models exist for:

- Corrosion of reinforced concrete
 - *Chloride -induced*
 - *Carbonation -induced*
- Freeze-thaw damage of concrete
- Fatigue of metals (esp. steel)

Model for chloride diffusion into concrete based on Fick's Law

$$C(x,t) = C_s + (C_i - C_s) \cdot \left[\operatorname{erf} \left(\frac{x}{2 \sqrt{D_{app}(t) \times t}} \right) \right]$$

$$D_{app}(t) = D_{app}(t_0) \left(\frac{t_0}{t} \right)^\alpha$$

where:

$C(x,t)$	=	chloride content at depth x and time t
C_s	=	chloride content at the concrete surface
C_i	=	initial chloride content of the concrete
$D_{app}(t)$	=	apparent diffusion coefficient of chloride in concrete
$D_{app}(t_0)$	=	apparent diffusion coefficient of chloride measured at reference time t_0 ,
erf	=	the error function
α	=	aging factor, which decreases with time and likely lies between 0.2 and 0.8

Service Life Design

- **Partial factor** – partial safety factors (e.g. load and resistance factors) allow designers to evaluate limit states given specific target reliability indices during the design process.
 - *Partial factors are derived from full probabilistic data, similar to AASHTO LRFD for structural design.*
- **Deemed -to -Satisfy** – provides designers with a set of prescriptive requirements which, if followed, should produce a bridge with a service life above the minimum specified (for assumed reliability indices)
 - *Deemed -to -satisfy is most common, often driven by inability to define precise limit states and lack of reliable models of deterioration mechanisms.*

Service Life Design

Deemed -to -satisfy

Criteria may be general for an element or for specific deterioration mechanisms.

- Concrete material specifications – acceptable types classes of constituents
- Mix design - w/cm , cement content, compressive strength, air content, etc.
- Concrete cover dimensions
- Crack control approaches – rebar sizes and spacing
- Coatings – steel coatings, membranes/overlays for concrete
- Replaceable elements

“Deemed-to-satisfy” provisions are usually tiered, with more stringent provisions keyed to harsher exposure classes.

Service Life Design

Replaceable Elements

Most common:

- Bearings
- Expansion joints
- Railings/parapets/barriers

May include:

- Cables, stays, hangers
- Anchorages and tendons

Also:

- Wear surfaces, overlays, membranes
- Drainage elements
- Paint systems

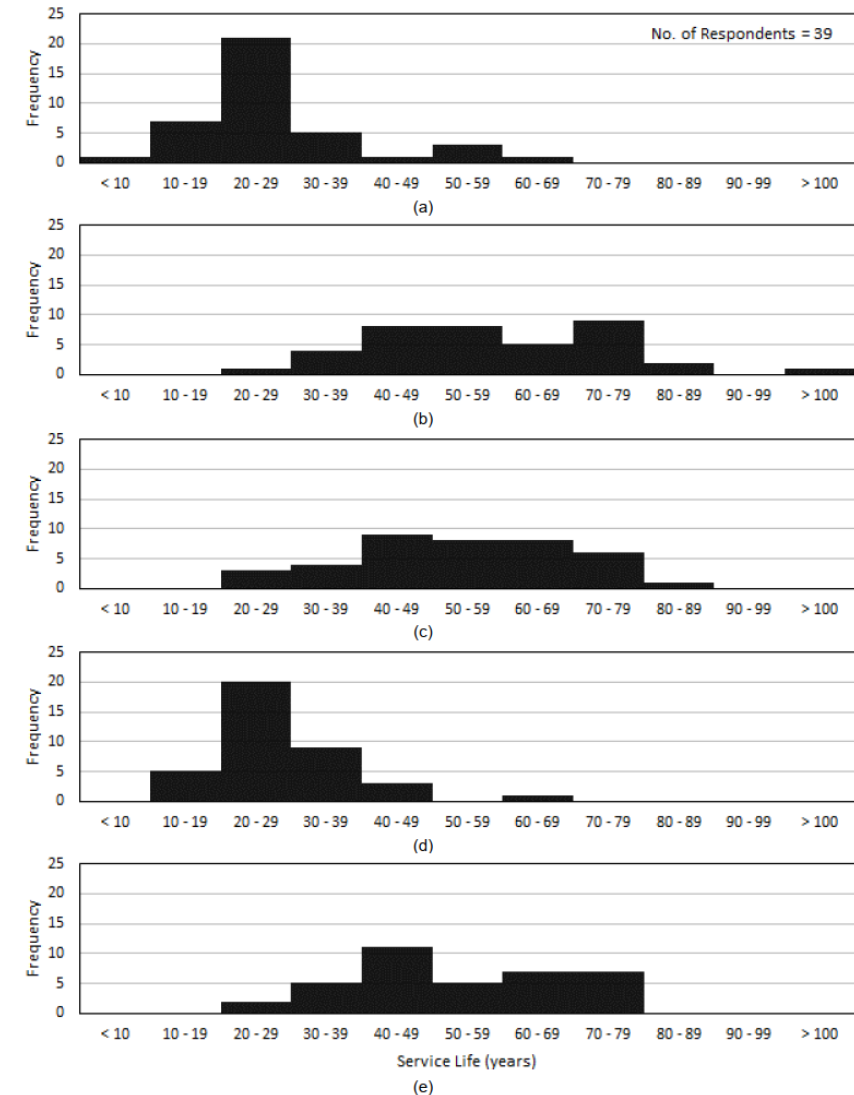

Figure 16. Target service lives for (a) joints, (b) bearings, (c) decks, (d) paint, and (e) parapets.

Source: from NCHRP Web-Only Document 269 (2019)

Strategies to Design for Service Life

Avoidance

Remove vulnerability by:

- removal of vulnerable details (e.g., joint elimination)

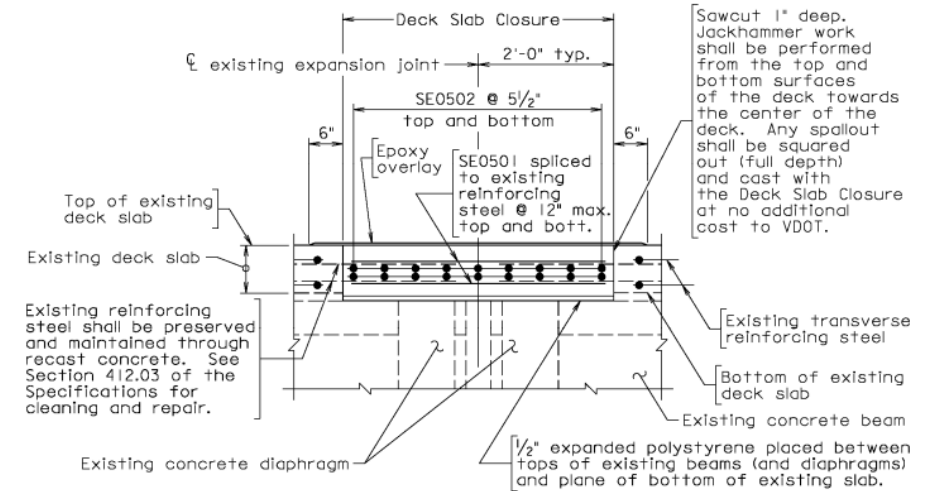

Flexible Link Slab With Epoxy Overlay Using A4 Modified Concrete Detail

Source: from Virginia DOT Manual of the Structure & Bridge Division, Chapter 32 (2018)

- use of corrosion resistant materials (e.g., stainless steels).



Stainless steel reinforcement



Carbon-fiber reinforced polymer strand

Implementation of 100 -year Service Life

It's a team effort!

- Durability must be applied diligently and continuously throughout the process of design, construction and throughout the maintenance period
- Cannot in construction invoke "industry standard" practice or level of care as the bar for performance if that standard was not developed to support the target design life.
- Focus the design and construction team to go beyond the standard durability response, to explore new means of achieving an extended service life and achieve a higher level of performance.

How does Quality Assurance play a role?

Quality Assurance is a key factor in successful implementation of service life design

- Materials qualification and acceptance
- Fabrication and handling
- Erection and Placement
- Surface preparation
- Post-construction verification

Quality Assurance is critical in ensuring the materials specified are fabricated, delivered and placed in a method that sustains the integrity of the design.

QA to achieve 100 -year Design: Concrete

Design parameters include concrete constituent materials quality, reinforcement type and detailing, and sometimes protective systems (coatings, sealers and overlays)

Key Steps: Qualify a mixture design, ensure it is placed properly and has appropriate in-situ characteristics

Qualification:

- Screen/certify materials (avoid AAR, damaged bars, etc.)
- Evaluate mix for performance parameters
 - *Fresh properties*
 - *Hardened properties*

QA to achieve 100 -year Design: Concrete

Construction: QA role is critical in ensuring concrete material quality and to avoid compromising the design ..beyond slump/flow, air content and compressive strength, factors include:

- Permeability (resistivity as surrogate)
- Shrinkage and creep (control w/cm & paste content)
- Heat of hydration / Thermal stress (cooling/low heat mix)
- Consolidation and Finishing
- Proper curing (method and duration, accelerated curing)

QA to achieve 100 -year Design: Steel

Assure elements conform to design and shop drawings to avoid errors in fabrication and construction

- Correct materials with certifications
- Correct dimensions, cambers, connections, fit-up
- Quality of welds (proper penetration, no inclusions, minimize residual stresses)
- Proper assembly and tightening of mechanical connections
- Proper surface preparation and coatings application (paint, HDG, metalizing)

Fabricated elements must be handled erected to avoid damage to elements or protective systems



QA to achieve 100 -year Design: Prestressed and Post-tensioned Concrete

Quality assurance for prestressing and post-tensioning requires controls on high-strength strand and encapsulation systems

- Strand materials certification/verification
- Monitoring of tensioning operations
- Proper placement/curing of concrete
- Shipping and handling of precast elements
- P/T duct integrity (anchorage, duct, couplers, grout tubes & vents)
- Grout/filler integrity (materials, pumping, no voids/segregation)
- Protection (end caps, waterproofing of anchorages)
- Post-fabrication screening for cracking/voids



QA Example: GPR Cover Depth Survey of Deck

GPR survey of top mat reinforcement

- *1.6 GHz ground couple antenna and GPR system.*
- *Longitudinal scans at 5 -ft intervals; 60 scans per ft*
- *Top-mat transverse bars were identified and the depth calculated*

GPR depths correlated to pachometer or drill probe depths at discrete locations.

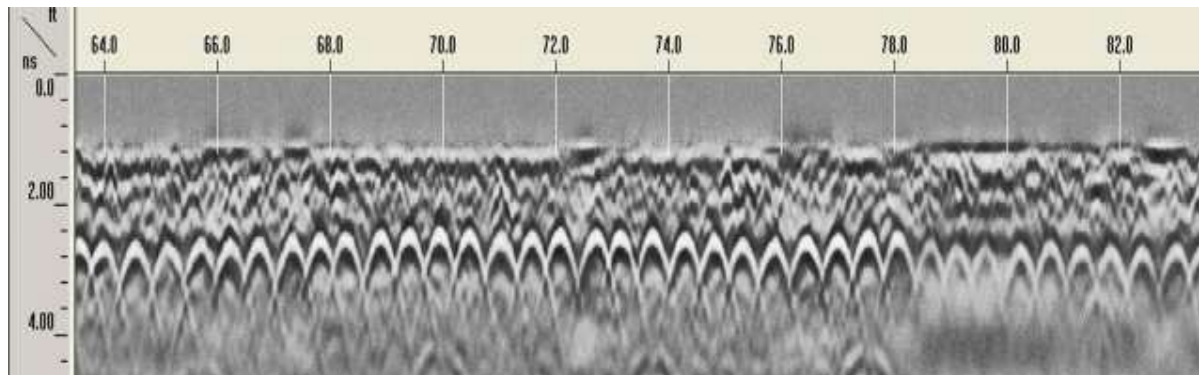

QA Example: GPR Cover Depth Survey of Deck

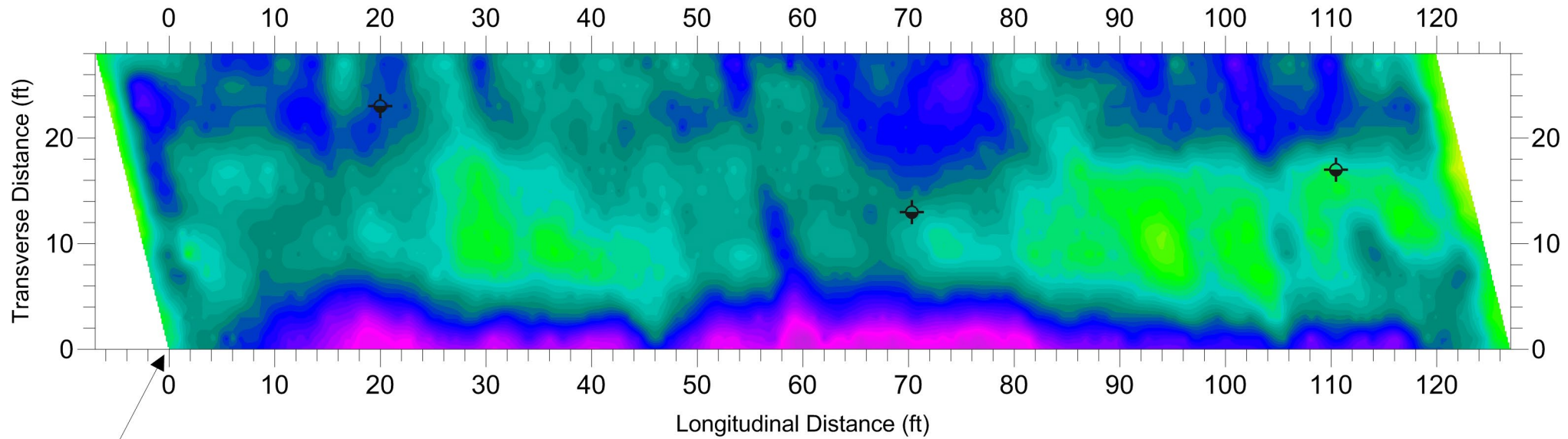

Origin at inside face of parapet and joint between south approach slab and deck.

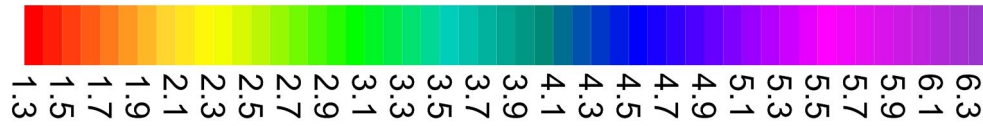

Approximate Top Rebar Clear Cover Depth (Inch)

How does this knowledge aid in achieving service life?
 What QA would you suggest to prevent this?

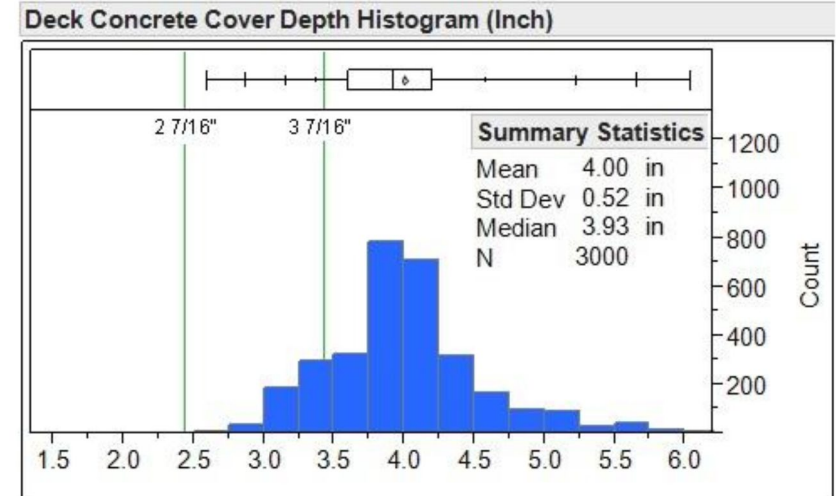

QA Example – Impact Echo to Assess Deck Thickness

Construction QA:

Two simple -span, ~80 -ft concrete deck on concrete beams w/sip forms

Two -stage deck placement

Exterior girder rotated in stage 2

Survey to measure deck thickness

Survey to measure cover depths

Could this have been avoided?

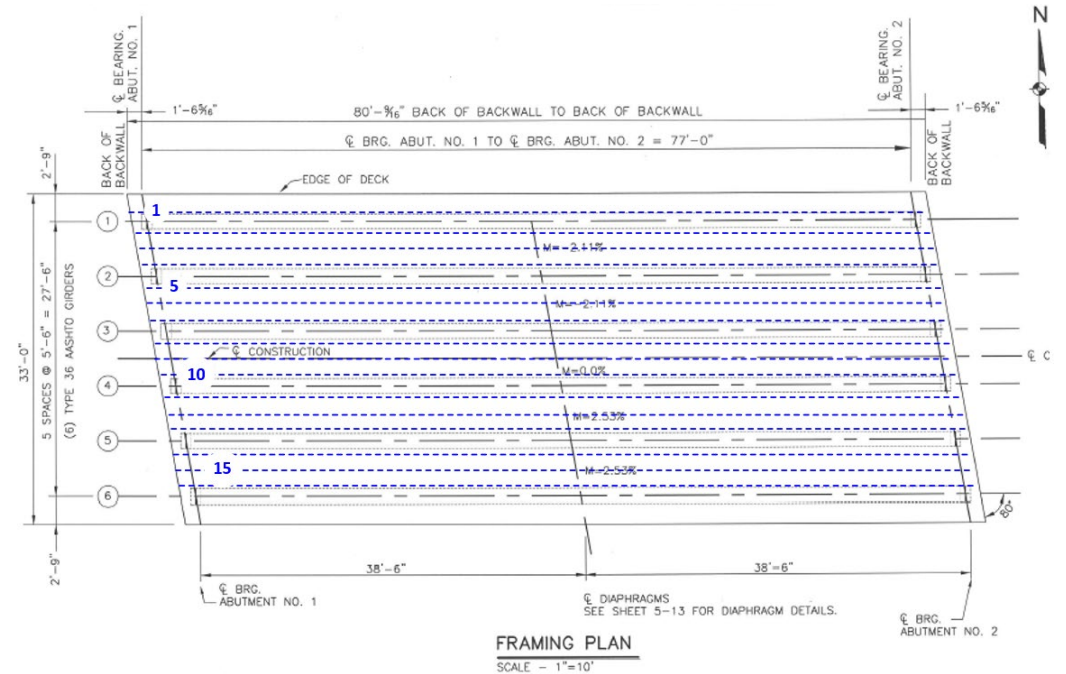

8.28	8.05	8.05	8.20	8.20	8.05	8.13	8.13	7.91	7.84	8.05	8.13	7.77	7.70	7.91	7.91	8.05	8.05	4.24	8.20	7.44
5.32	9.44	9.14	10.21	10.09	7.98	7.77	10.21	7.91	7.02	6.10	7.77	8.69	8.96	8.36	8.96	7.77	6.32	6.86	8.78	7.02
6.18	9.44	8.36	6.55	7.98	7.77	6.41	7.98	8.52	7.98	6.10	6.14	6.80	6.70	10.33	6.65	6.65	6.55	8.20	8.20	6.05
7.70	6.97	8.69	6.10	6.01	7.50	7.70	7.57	8.28	8.44	8.36	6.75	5.49	6.80	5.89	5.97	7.50	6.27	7.84	8.05	7.44
5.23	7.25	7.63	6.10	7.25	6.97	8.36	5.89	5.19	8.28	7.44	6.97	7.14	7.08	7.02	7.98	8.52	8.28	8.05	9.24	6.01
4.80	6.91	7.91	7.57	5.74	5.70	6.01	7.77	7.57	7.32	7.14	7.08	5.85	5.49	7.32	5.70	5.16	7.50	7.38	7.77	7.25
7.38	6.23	6.60	6.97	4.37	6.80	7.57	6.70	7.25	9.14	6.80	6.75	5.66	6.91	7.08	5.85	6.97	6.80	5.66	7.14	7.91
5.78	7.20	7.70	6.41	6.65	5.81	5.85	6.27	6.45	5.97	6.23	5.81	7.14	7.08	8.20	6.65	6.32	6.60	5.97	5.89	7.50
6.32	8.13	8.52	7.77	7.63	7.63	8.36	7.44	7.57	7.77	7.91	7.77	8.05	8.05	8.20	8.13	7.77	8.13	8.13	7.91	7.91
7.98	8.28	8.13	7.84	7.57	7.70	7.50	7.25	7.63	7.98	7.38	7.70	7.98	7.84	7.91	7.91	8.13	7.57	8.20	8.20	8.36
8.36	8.69	8.61	8.61	8.78	8.87	8.78	8.52	8.13	8.20	8.61	8.69	8.52	8.13	8.69	8.87	8.87	8.87	8.96	8.28	8.87
7.25	7.98	8.13	8.28	8.13	6.91	6.75	6.70	8.52	9.86	6.41	6.91	6.91	8.36	7.02	6.91	6.65	8.05	8.78	8.05	
6.01	6.70	6.45	6.80	9.14	9.05	7.50	8.69	8.52	8.78	7.91	7.91	7.98	8.05	6.80	8.28	8.13	8.36	8.28	8.61	8.44
7.20	6.10	6.60	8.96	9.34	9.24	9.24	8.69	8.52	8.44	7.32	7.70	8.96	8.78	9.14	9.86	9.54	9.65	9.75	9.75	9.65
6.97	9.05	6.97	7.08	7.02	8.36	8.36	7.02	7.98	6.41	7.91	8.87	10.21	6.86	7.02	8.61	7.14	7.25	7.20	7.25	9.54
7.20	9.24	9.54	9.24	9.65	9.24	9.24	9.54	8.52	7.84	8.52	8.36	8.96	9.14	9.24	8.28	9.65	9.05	9.65	7.91	9.24

QA Example: Thermal restraint cracking

Problem:

- QA identified cracking
- Excessive heat developed in tower pour because of failed cooling pipes
- Cracking occurred in the main towers from inadequate control of restraint caused thermal conditions

Solution:

- Changed mixture design to low heat of hydration concrete with fly ash for use in towers

How might proactive QA have prevented this?



Thermal design to prevent restraint cracking at lifts



Don't forget the basics

On a recent project with exterior concrete building wall panels designed for 100 -year service life, a subcontracted precast fabricator:

- Did not achieve appropriate cover depths of reinforcement
- Did not obtain adequate air entrainment in concrete
- Did not have adequate controls of water content of the aggregates (hence final w/cm is unknown)
- Used an unapproved ASR -prone aggregate source
- Falsified QC records to cover up these inadequacies

Do you think this facility will last 100 years?

CONCLUSIONS

- 100-year Design Life has become a common expectation
- “Business as usual” will not serve our cause
- Proper implementation requires unified team focus
- Quality Assurance plays a critical role in ensuring the service life design is implemented as planned
- Pro-active actions can prevent costly problems

Thank you!

Michael.C.Brown@wsp.com

wsp