

# **COMPACTION OF FILL MATERIALS**

**Course Reference Manual**



**pennsylvania**

DEPARTMENT OF TRANSPORTATION

BUREAU OF PROJECT DELIVERY  
INNOVATION AND SUPPORT SERVICES DIVISION  
GEOTECHNICAL SECTION

**APRIL 2020**



## Table of Contents

Preface.....	i
Chapter 1 – INTRODUCTION.....	2
1.1 Construction Materials .....	2
1.2 How is Soil Different from Other Construction Materials.....	3
Chapter 2 - WHAT IS COMPACTION.....	5
2.1 Definition of Compaction.....	5
2.2 Why is Compaction Important .....	7
2.2.1 Increased Shear Strength .....	8
2.2.2 Decreased Hydraulic Conductivity.....	8
2.2.3 Pavement Performance .....	10
Chapter 3 – SOIL PROPERTIES .....	10
3.1 What is Soil .....	10
3.2 Grain Size.....	12
3.3 Gradation.....	15
3.3.1 Gradation Curves .....	15
3.3.2 Gradation Curve Analysis – Characteristics of Different Gradation Types.....	15
3.3.3 Impact of Surface Area.....	19
3.4 Mineralogy – Clay Minerals .....	23
3.5 Shear Strength and Behavior of Soil Masses .....	27
3.5.1 Cohesionless Soils – Friction .....	27
3.5.2 Cohesive Soils – Cohesion .....	30
3.6 Field Testing of Fine-Grained Soils – Plastic versus Non-plastic Materials .....	31
3.7 Non-plastic Silts .....	36
Chapter 4 – FUNDAMENTALS OF COMPACTION.....	37
4.1 Moisture-Density Testing.....	37
4.2 Interpretation of Moisture-Density (M-D) Testing .....	41
Chapter 5 – Compaction Equipment.....	48
5.1 Introduction .....	48
5.2 Smooth Drum Vibratory Roller.....	48
5.3 Padfoot Roller .....	49
5.4 Hand Operated Equipment.....	50
Chapter 6 – Mechanics of Compaction.....	53

6.1	Introduction .....	53
6.2	Static Compaction .....	55
6.3	Dynamic (Vibratory) Compaction .....	57
6.4	Roller Speed .....	58
Chapter 7 – Field Operations .....		60
7.1	Introduction .....	60
7.2	Placement .....	61
7.3	Compaction .....	62
7.4	Quality Control, and Acceptance and Verification .....	63
7.4.1	Acceptance Based on Moisture-Density Control .....	63
7.4.1.1	Testing Frequency.....	63
7.4.1.2	Moisture and Density Requirements.....	63
7.4.1.3	Nuclear Moisture and Density Gauge - Description.....	64
7.4.1.4	Nuclear Moisture and Density Gauge - Operation .....	67
7.4.1.5	In-place Moisture and Density Testing with Nuclear Gauge – PTM No. 402 .....	71
7.4.2	Acceptance Based On Non-movement.....	72
7.5	Operational Considerations and Potential Problems.....	72
7.5.1	Moisture-Density – Going from the Lab to the Field.....	73
7.5.2	Achieving More Than 100% Required Density .....	74
7.5.3	Monitoring and Controlling Lift Thickness with the Nuclear Gauge .....	76
7.5.4	Build-up of Soil on Drum Between Rows of Pads on Padfoot Roller .....	76
7.5.5	Defining Non-movement.....	79
7.5.6	The Problem Soil – Non-plastic Silt.....	81
7.5.7	Drainage.....	82
7.6	Summary of Field Operations .....	84

## Preface

This manual is intended to be the companion instruction manual for the Department's "Compaction of Fill Materials" class, accompanying the PowerPoint presentation used for the class. The manual will follow the PowerPoint presentation in structure and content. As indicated in the table of contents, the manual will be broken down into eight topical areas which align directly with the PowerPoint presentation.

The intended audience for this manual is broad, including any individual involved with or needing to better understand the materials and processes involved with the placement and compaction of earth materials. It was not practical to tailor the manual to the individual backgrounds and experience of such a broad ranging audience. Some of the information presented may be very familiar to some, while completely foreign to others. Every effort was made to present the information in a manner that could be both relevant and understood to the range of potential users. As such, simplifications were adopted for some concepts and information to avoid unnecessary and unproductive explanations.

We are always attempting to improve the quality and effectiveness of our products. Any feedback concerning this manual or the companion course that may assist us towards this end is welcomed and appreciated. Comments and requests may be sent to the following resource account: [GeoPub222@pa.gov](mailto:GeoPub222@pa.gov). Please note that this resource account covers a range of publications and products. When offering feedback, please be specific as in content and relative to the product it concerns.

## Chapter 1 – INTRODUCTION

### 1.1 Construction Materials

There are a range of materials used in the construction of highways and their various component structures (embankments, pavements, pavements bases and foundations, walls, bridges, sign and light posts, guide rail, drainage pipes and culverts, etc.). The more common highway construction materials include:

- Steel
- Plain Cement Concrete
- Asphalt Concrete
- Manufactured Aggregates
- Geosynthetics
- Earth Materials (Soil and Rock)

Each of these materials has properties and costs, making the material suitable and effective for the specific application or component of highway construction for which they are used. Each of the materials has very specific set performance characteristics that must align with the needs of the intended application or function. It is a combination of the performance characteristics and material costs that ultimately dictate the selected materials.

Of the materials listed above, by volume, earth materials (soil and rock) are by far the most common materials used on highway construction projects. There are some significant fundamental differences between earth material and the other five listed common highway construction materials. Earth materials differ from the other materials in that they:

1. are natural materials;
2. are not manufactured;
3. have no quality control (QC) plan when they were formed;
4. are not uniform;
5. and are highly variable (have highly variable physical properties).

In terms of the variability of their physical properties, this includes the broad range in characteristics of earth materials in general (clay to massive rock), and the variability of earth material deposits both laterally and vertically.

When and how QC and QA (quality assurance) are addressed is also very different for earth materials. Such processes and controls take place primarily in the field during construction, that is during placement and compaction – not before the material is delivered to the construction site. Construction specifications become the primary QC and QA tools.

In effect, the construction site becomes a manufacturing facility for earth structures, with the critical manufacturing specifications including:

- required lift thickness;
- uniform lift thickness;
- compaction using the proper equipment; and
- compacted at proper moisture content (if applicable) and to the required density.

Ultimately, it is a combination of contractor and Department personnel ideally working as a team who are ultimately responsible for proper and effective QC, QA and verification relative to placement and compaction of soil and rock.

To summarize the above discussions, it is crucial to recognize and appreciate that earth materials, soil and rock, are natural materials and are not manufactured. Because they are natural and not manufactured, there is no QC or QA and they are inherently not uniform and highly variable in both substance and performance. The best way to think about the placement and compaction of earth materials is as a raw material that is being “manufactured” into an engineered structure – whether it be an embankment, fill or subgrade. It is either manufactured into a structure on site (e.g. an embankment) or becomes an extension of another structure (e.g. the foundation for a pavement, fill for a wall or abutment, or integral component of a reinforced fill). In all cases, proper function of the earth material is critical to the required and adequate function as a structure, or component of a structure. The QC and QA for the “manufacturing” of the structure or structure component, occurs during placement and compaction. The process of placement and compaction is the manufacturing process.

**NOTE:** In order to avoid any confusion, it should be noted that although the above discussion concerns earth materials in general, much of the discussion that follows will focus on soil masses (as opposed to fractured rock masses or shot rock). The reasons will become evident as we proceed. Just realize that the difference between the materials is primarily one of scale (particle size). The two materials behave very similarly. Most of the concepts to be presented in the course apply to both soil and rock (especially granular soils such as sand and gravel versus rock).

## **1.2 How is Soil Different from Other Construction Materials**

Another difference between earth materials (soil and aggregated rock) and other common construction materials (steel, concrete, wood) are their strength characteristics. Different materials mobilized and exhibit strength in different ways (see Table 1.1-1). For example, concrete is strong in compression but weak in tension and bending (flexure). By contrast, steel and wood perform well under all three types of load. All three of the above materials are comprised of bound solid masses, whereas soil is composed of a mass of individual particles. Because soil is composed of discreet particles, as a mass it must resist applied loads from resistance between the particles. It therefore resists applied loads in shearing between the particles, and soil (and aggregate) strength is described and measured in terms of shear strength and shear stress.

Table 1.1-1 – Relative Strength of Various Materials				
Material	Loading Type			
	Compression	Tension	Bending	Shear
Concrete	Good	Poor	Poor	Good
Steel	Good	Good	Good	Good
Wood*	Good	Good	Good	Good
Soil	Poor	Poor	Poor	Varies

\* Parallel to the direction of the grain

The shear strength of soil is best described by the shear strength equation:

$$S = c + \sigma' \tan(\phi)$$

Where:

- S = shear strength, (psf)
- c = cohesion, (psf)
- $\sigma'$  = effective overburden stress (the stress resulting from soil particles being pushed together), (psf)
- $\phi$  = soil friction angle, (degrees)

As can be observed from the equation, soil shear strength has two distinct components – cohesion and friction. Cohesion is the ability for a material to be deformed and hold its shape – much like plastic. Cohesive soils are described as having plastic behavior. Cohesive soils behave like modeling clay or playdough. The source of cohesion is an attraction between particles at the molecular level. While not fully understood, it is believed that cohesion develops from a combination of weak cementing between particles, electrostatic and electromagnetic attractions between particles, and valence or molecular bonding.

True cohesive behavior in soils is only exhibited by soils containing clay minerals. Other soils (such as very fine sands and silts) may exhibit some apparent cohesion which results from particles being weakly held together by surface tension from moisture surrounding the particles. Both the clay mineral type and content influence the level of cohesion observed, with different clay minerals exhibiting varying levels of cohesive strength. Water content also impacts the level of cohesion observed. Clays have a general affinity for water, but as increasing amounts of water are absorbed, the water pushes the clay particles farther apart, weakening the molecular bonds and attractive forces creating the cohesive strength. This is why clay soils become increasingly soft and weaker as moisture content increases.

To understand the frictional component of soil shear strength, think of the behavior of sand. Sand exhibits no cohesion. Therefore, it does not hold its shape without any external confinement. Such materials are termed cohesionless. Sand will take the shape of the container it occupies. The source shear strength for cohesionless materials is the resistance between the surfaces of the individual particles – friction. Friction develops as a result of the interaction of the irregular surfaces of adjacent particles or particle asperities. The more irregular or rougher the surfaces, the greater the potential friction that can be mobilized between particles.



Note that increased roughness only increases the “potential” for frictional shear strength. In general, the rougher the surface the higher the friction angle of the surface. However, friction angle is only one of the two factors in the friction component of shear strength. Inspection of the shear strength equation shows that the friction component of shear strength is the product of effective overburden stress and the tangent of the friction angle ( $\sigma' \times \tan(\theta)$ ) – the two are multiplied to get the value of the friction component of shear strength.

Therefore, frictional resistance, the resistance between the individual soil particles, can only be mobilized if there is some applied force resulting in stress between the particles. This is the effective overburden stress. The higher the stress, the higher the frictional component of shear strength and the higher the soil shear strength. So while the cohesive component of shear strength is not affected by applied loads and the resulting stresses in the soil mass, the frictional component relies on the stress from applied loads to mobilize shear strength from soil friction.

## Chapter 2 - WHAT IS COMPACTION

### 2.1 Definition of Compaction

Depending upon the source, compaction of earth materials has been defined in a variety of ways but with the same general conclusion. A composite technical definition from the various sources is as follows:

Compaction is the densification of soils and aggregates by application of mechanical energy.

From a practical standpoint, a much simpler physically descriptive definition can be adopted:

Compaction is the **reduction of air voids** in soil or aggregate.

This definition is graphically illustrated in Figures 2.1-1 and 2.1-2 below. Figure 2.1-1 is a phase diagram illustrating before and after compaction conditions. A phase diagram shows the three parts of the soil structure as individual components: solids (soil particles), water and air. The diagram depicts an unspecified but specific weight of soil. The diagram illustrates the three components both on a volumetric basis (the volume of each component) and on weight basis (the weight of each component). In the diagrams, the total volume is the sum of the volume of solids and volume of voids (the voids being the sum of the volume of water and volume of air). The total weight is the sum of the weight of the solids and weight of the water (the weight of air being zero).

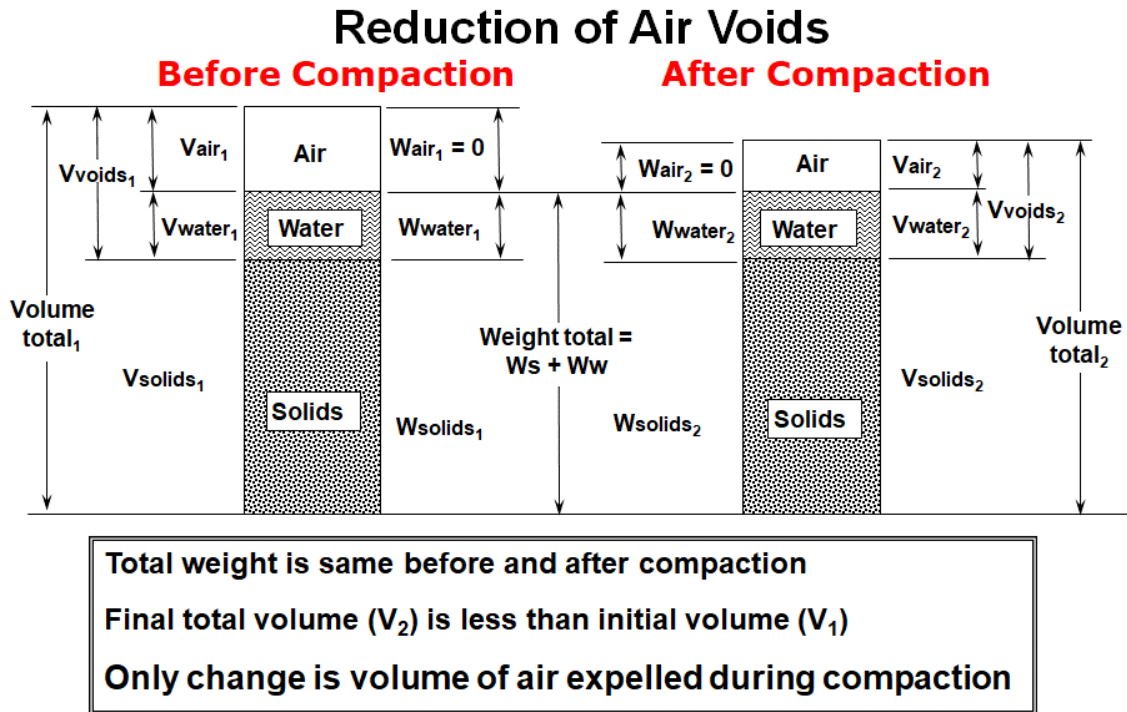

Figure 2.1-1 – Phase Diagram Illustrating the Result of Compaction

Note that the only difference between the two diagrams before and after compaction is a reduction in the volume of voids – specifically the volume of air voids. The volume and weight of both the soil solids and water does not change from before to after compaction. The only impact to the phase diagrams from compaction is a reduction in air voids. Figure 2.1-1 clearly illustrates that from a practical perspective, compaction of earth materials is simply a reduction of air voids within the material matrix.

This concept is also illustrated in Figure 2.1-2 which depicts the arrangement of soil particles before and after compaction. The diagrams show that after compaction, there is an increase in soil solids and water within the same depicted volume. In order to have an increase in the amount of soil solids and water within the unchanged volume, there must be a reduction in voids. Again, compaction of a soil mass is shown to result in a reduction in soil voids – specifically air voids.

# Reduction of Air Voids

## Before Compaction

## After Compaction

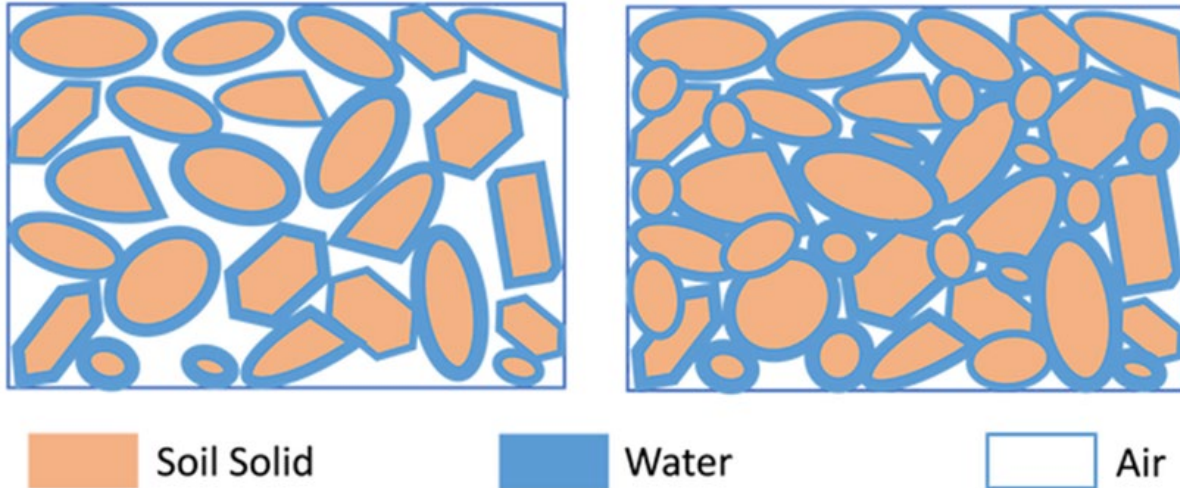

Figure 2.1-2 – Soil Particle Arrangement Before and After Compaction

## 2.2 Why is Compaction Important

While from a practical perspective compaction can be thought of as nothing more than a reduction in soil air voids, compaction of earth materials has a specific objective and purpose – to improve the engineering properties of the earth mass. Compaction improves the soil behavior and engineering properties having a variety of impacts including the following:

- **Increasing shear strength**
- **Decreasing hydraulic conductivity (for fine-grained soils – most PA subgrades)**
- Reducing settlement
- Improving slope stability
- Improving bearing capacity
- Reducing volume changes
- Improving frost resistance

Note that the first two items in the above list are bolded. These are the primary physical impacts of compaction that result in the remaining benefits indicated in the list. These first two items will be discussed briefly in the following two sections.

### 2.2.1 Increased Shear Strength

The most important impact of compaction is that it increases material shear strength. Increasing shear strength permits the material to resist applied loads with minimal or limited deflection. Increasing the material shear strength directly results in four of the other listed material behavioral improvements:

- Reducing settlement
- Improving slope stability
- Improving bearing capacity
- Reducing volume changes

Ideally, the compaction load is largest load the material should ever be subjected to or experience.

To understand the mechanism of how compaction increases material shear strength, we can look again at the shear strength equation:

$$S = c + \sigma' \tan(\theta)$$

Recall that  $\sigma'$  is the effective overburden stress and  $\theta$  is the material particle to particle friction angle. The effective overburden stress is a function of the existing load and/or previously applied overburden loads (including compaction loads). When compaction loads are applied there is an increase in overburden stress and the material particles are pushed closer together in a more tightly packed arrangement (resulting in a reduction in air voids).

When the compaction load is removed, the material particles remain more tightly packed, with increased stress between the particles. The removal of the compaction load does not restore internal stresses to their original condition, rather the rearrangement and tighter packing of particles results in a residual increase in stress at contacts between the particles, and therefore, an increase in  $\sigma'$ , the effective stress. From the shear strength equation, it is observed that as  $\sigma'$  increases, then  $\sigma' \tan(\theta)$  increases and the overall shear strength (S) increases.

### 2.2.2 Decreased Hydraulic Conductivity

Although the terms hydraulic conductivity and permeability strictly represent different values and have different units, they are often used interchangeably. The difference between the two values is subtle. However, for the purposes of the discussions in this manual, we will consider the two values to be the same. Hydraulic conductivity is a measure of the ease with which water flows through a material. The faster water flows through the material, the higher the hydraulic conductivity. The slower the flow, the lower the hydraulic conductivity. Hydraulic conductivity has the same units as velocity – e.g. feet/day.

By pushing soil particles closer together and decreasing soil voids, compaction reduces the soil hydraulic conductivity/permeability which creates a greater resistance to the flow of water (see Figure 2.2-1). For open graded granular soils, the impact to permeability is not significant. However, for fine-grained soils tighter packing increases the resistance to

infiltration. Normally, higher soil permeability is desired for more free-draining materials. Pennsylvania subgrade soils are almost always fine-grained having poor (low) permeability, and generally poor engineering properties. For fine-grained subgrade soils, it is advantageous to exploit the permeability “deficiency” to help protect long-term material integrity and performance.

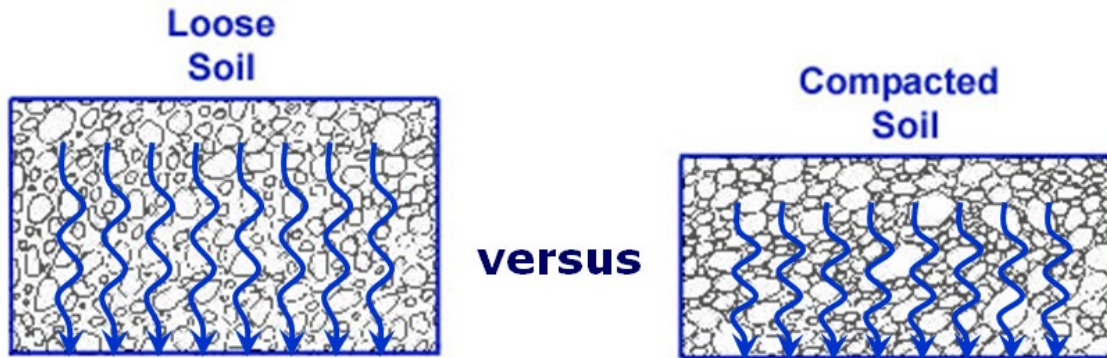

Figure 2.2-1 – Impact of Compaction on Soil Hydraulic Conductivity

The deficiency in hydraulic conductivity is exploited in two ways. First, as indicated above, compaction reduces soil hydraulic conductivity. Minimizing hydraulic conductivity minimizes infiltration of water into the soil. Minimizing infiltration protects the subgrade. This is important for fine-grained soils. Once infiltration is minimized, the subgrade soil is resistant to damages and weakening due to water and freezing. The subgrade soil surface is sloped to give the water a place to flow following the path of least resistance, instead of vertically into the subgrade (see Figure 2.2-2). The subgrade surface is sloped to direct the water to the pavement base drain (or other drainage layer), so that it cannot damage the pavement foundation (the subgrade).

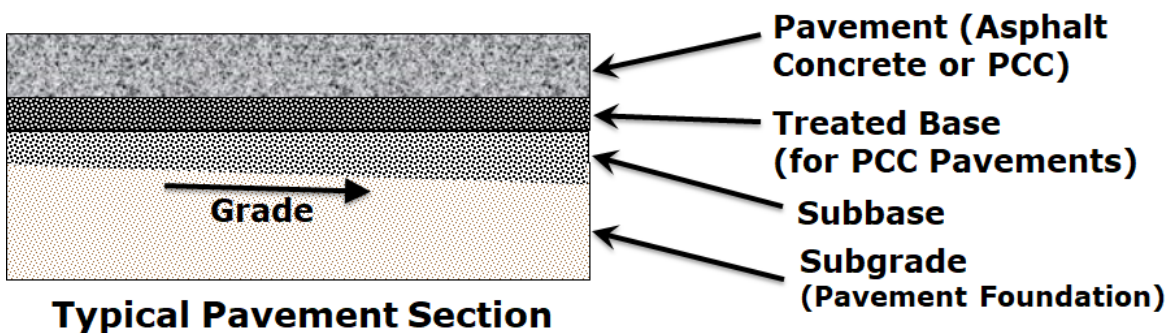

Figure 2.2-2 – Impact of Compaction on Soil Hydraulic Conductivity

To summarize, compaction not only increases the shear strength of subgrade but provides greater resistance and protection from damage to freezing and thawing. Proper and effective compaction of subgrades (i.e., the pavement foundation), is crucial to help assure the long-term performance of pavements.

### **2.2.3 Pavement Performance**

Another reason why proper and effective compaction is important concerns pavement performance. An earth material layer of particular importance in highway construction is termed the subgrade. Subgrade is not characterized as a particular type of material, in fact subgrade can consist of any material meeting specification requirements. Rather, subgrade is characterized by its location (see Figure 2.2-2 in Part 2 above). From an operation perspective, subgrade can be considered to consist of the material that extends a minimum of three (3) feet below the pavement structure (below the bottom of the subbase layer). The following are four characteristics that define the nature of subgrade. Subgrade is:

- the foundation for the pavement structure;
- located directly beneath the subbase;
- material that usually consists of soil; and
- NOT a manufactured material – natural material.

While proper and effective compaction is important for all layers of earth materials because of the above listed characteristics, it is emphasized as particularly crucial for subgrade, especially in light of the challenges and vulnerabilities that exist with subgrades. The performance of any structure will be no better than the quality and adequacy of the structure's foundation.

This is no less true (and likely even more critical) for pavement structures. Subgrade is the foundation for the entire pavement structure. Extra care and attention should always be given to placement and compaction of the subgrade layer. Factors that can impact the performance of subgrade include: physical and chemical properties of the material, construction technique (i.e. placement and compaction), service conditions (e.g., loading, drainage, etc.) and seasonal weather variations.

## **Chapter 3 – SOIL PROPERTIES**

### **3.1 What is Soil**

When working with soil, there are a wide variety of properties that may have to be considered. However, before considering some of the soil properties pertinent to compaction, it is important to first understand what soil is and its general nature.

Soil is a material composed of a combination of discrete solid particles, air, and water (see Figure 3.1-1). The solid particles are comprised of grains of natural mineral aggregates that can be easily separated by mechanical means. The individual grains are the product of weathered rock.

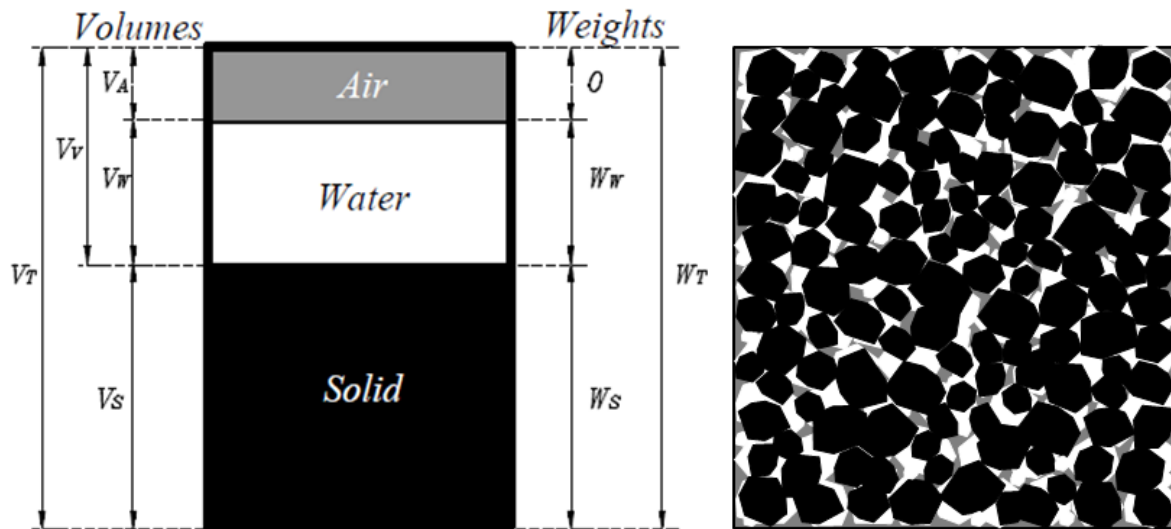

Figure 3.1-1 – Soil Composition – Solid Particles, Water and Air

In Chapter 1 (Introduction) we saw that earth materials (soil and rock) are different than other construction materials in that they are:

1. natural materials;
2. not manufactured;
3. not subject to a QC plan when made;
4. not uniform; and
5. highly variable

In addition, there are some other significant differences between earth materials (especially soil) and the other listed common roadway construction materials. Earth materials represent the biggest unknown on any project and are typically the least controlled material on a project. The most consistent property of soil is its inconsistency. As a result, earth materials present the highest associated risk for highway construction projects.

The specific properties of earth materials that are of importance will depend upon the specific needs and application. This section will deal with a number of soil properties that are significant relative to compaction. These properties include:

- Grain Size
- Gradation
- Mineralogy
- Shear Strength and Behavior of Soil Masses

### 3.2 Grain Size

Grain size is simply the size of a soil grain. While soil is composed of a combination of discrete solid particles, it is the individual grain sizes that define the makeup of the combination of particles. The purpose of this section is simply to provide a working reference for the various particle sizes and their descriptors that will be used through this course. AASHTO defines the classification of grain size ranges as indicated in Table 3.2-1 below.

Grain Size Description	Grain Size Range
Gravel	< 3 inches to $\geq$ No. 10 sieve
Sand	< No. 10 sieve to $\geq$ No. 200 sieve
Silt	< No. 200 sieve to $\geq$ 0.002 mm
Clay	< 0.002 mm

Table 3.2-2 provides a comparative description of the various AASHTO grain size designations. Objects similar in size to the upper and lower size limits of each particle designation are indicated for a practical reference. Note that the range is quite large, from less than 2 microns (0.002 mm) up to 75 mm, covering 5 orders of magnitude. This means that the upper bound limit of the largest particle (gravel) is approximately 38,000 times as large as the upper bound limit of the smallest particle (clay). From a strictly visual perspective, the range for gravel (2 to 75 mm) appears quite large, however, as can be observed from the upper to lower bound dimension ratios for each particle designation in Table 3.2-3, it is comparatively no larger in particle size range than sand or silt. It is simply that the limits for sand and silt particles are in scale that we are not able to visualize.

Table 3.2-2 – Comparative Description of AASHTO Grain Size Designations

Grain Size Designation	Particle Size Range	Comparative Objects	Object Size
Gravel	3 inches to No. 10 Sieve	Baseball to thickness of a U.S. Nickel (5 cent piece)	Baseball = 3 inches
Coarse Sand	No. 10 Sieve to No. 40 Sieve	Thickness of U.S. Nickel (5 cent piece) to grain of table salt	No. 10 sieve = 2.0 mm U.S. Nickel (5 cent piece) = 1.95 mm thick
Fine Sand	No. 40 Sieve to No. 200 Sieve	Grain of table salt to average thickness of human hair	No. 40 sieve = 0.42 mm Table salt grain = 0.4 mm
Silt	No. 200 Sieve to 0.002 mm	Average thickness of human hair to diameter of a red blood cell	No. 200 sieve = 0.075 mm Avg. Diameter Human Hair = 75 microns (0.075 mm)
Clay	Less than 0.002 mm	Approximate thickness of red blood cell	Approx. thickness of Red Blood Cell = 2 microns (0.002 mm)



Table 3.2-3 – Upper:Lower Size Ratios for AASHTO Grain Size Designations			
Grain Size Designation	Upper Limit Size Boundary, (mm)	Lower Limit Size Boundary, (mm)	Ratio Upper:Lower Boundaries
Gravel	75	3	37.5
Sand	2	0.075	26.7
Coarse Sand	2	0.4	5.0
Fine Sand	0.4	0.075	5.3
Silt	0.075	0.002	37.5
Clay	0.002	-	-

Note: The sand size designation is often further broken down into coarse and fine proportions. The boundary limits and boundary ratios for coarse and fine sand designations are provided in Table 3.2-3 for information.

Figure 3.2-1 provides a visual reference of AASHTO and ASTM particle size ranges. As can be observed, discerning individual particles becomes visually more difficult as grain size decreases. Particles passing the No. 200 sieve (silts and clays) are collectively referred to as fines. A particle just passing the No. 200 sieve is considered the smallest size that can be seen with the human eye without aid of magnification.

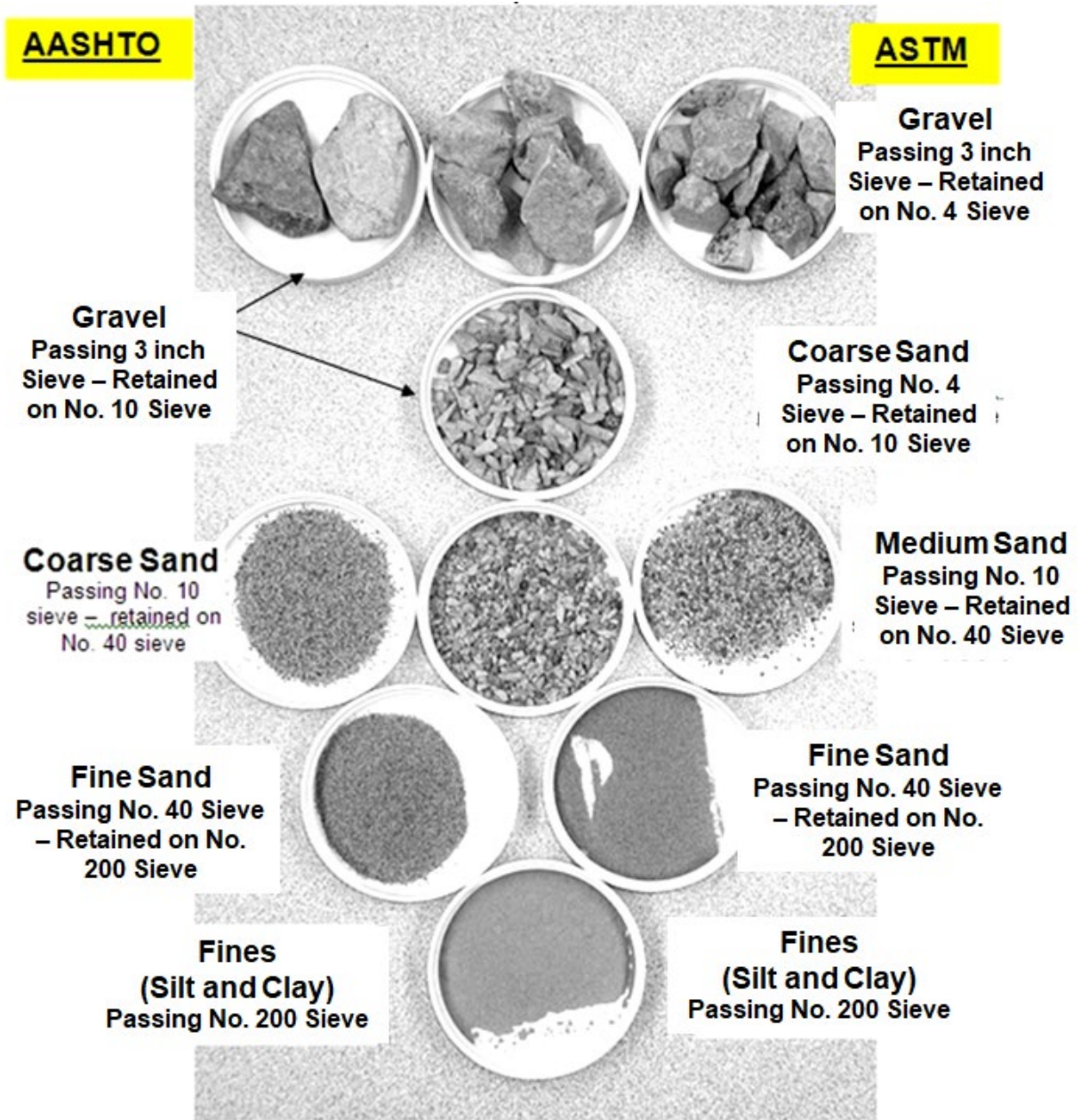

Figure 3.2-1 Visual Reference of AASHTO and ASTM Particle Size Ranges

### **3.3 Gradation**

While grain size addresses the individual soil particles, gradation focuses on the soil mass (i.e., the conglomeration of the soil particles). Gradation is one of the most significant properties of a soil mass that determines its behavior as an engineering and construction material.

Gradation is simply a way of defining and describing the distribution of soil or aggregate particle sizes.

#### **3.3.1 Gradation Curves**

The gradation of a material is determined by running a sample through a series of nested sieves having progressively smaller opening sizes. The sieves have standard size opening sizes, and the sieve nest is often referred to as a stack. The bottom of the stack will have a pan retaining the material passing the sieve having the smallest opening size. Material passing a sieve and retained on the next smaller standard sieve size is often given a +/- designation with the two sieve sizes. For example, material passing the No. 4 sieve and retained on the No. 10 size sieve can be described as minus No. 4/ plus No. 10 material (or -4/+10 material). If the arrangement of sieve sizes for a nest of sieves is standard for a specific application or test, the material might alternately be described by based upon the sieve on which it is retained (e.g. retained on the No. 10 sieve or +10 material), or by the sieve size it passed (e.g. passing the No. 4 sieve or -4 material).

Once a sample of known initial mass is run through a sieve stack, the mass of material retained on each sieve and the bottom pan, is collected and each fraction weighed to determine the mass of the individual fractions. The mass of each fraction is compared to the mass of the entire sample to quantify the material gradation. The gradation can be presented in tabular form or is shown graphically as the percent of material passing each of the standard sieve sizes in the stack. A graphical representation is known as a grain size distribution or gradation curve. Typically, a graphical representation is much more useful, as the shape and location of the curve is a significant aid in helping to determine anticipated soil behavior. It is very difficult to assess anticipated material behavior from gradation data presented in tabular form.

#### **3.3.2 Gradation Curve Analysis – Characteristics of Different Gradation Types**

Some of the soil behaviors or characteristics that can often be estimated or approximated from a gradation curve includes the anticipated relative shear strength and relative permeability. The terms relative and anticipated are stressed since the values cannot be quantitatively estimated from the gradation curve with any certainty or precision. Rather, relative behavior is implied when comparing to the strength and permeability characteristics (and other properties) of materials with similar gradations. The implied behavior is characterized as “anticipated” since, as will be demonstrated later in this course, actual material performance and properties are not determined solely by gradation.

Beyond strength and permeability, even more relevant to the primary topic of this course, a gradation curve can be very helpful in assessing anticipated behavior of a material during compaction. The gradation provides an indication of proper practices and equipment for compaction and can be very helpful in avoiding or assessing problems associated with

compaction of a material. As mentioned above, when assessing a graphical representation of material gradation, relative to compaction, shear strength or permeability, it is important to consider both the shape and location of the gradation curve.

Figure 3.3-1 illustrates the concept of shape and location when analyzing a gradation curve for anticipated material performance and behavior. The materials indicated on the curve are labeled as “Well Graded”, “Gap Graded” and “Uniform”. These three gradations represent the extremes of soil and aggregate gradation types.

A well graded material is comprised of a broad range of particles sizes resulting in a long smooth, nearly straight line, gradation curve. At the extreme other end of the spectrum is a uniformly graded or uniform material. A uniform material is composed of particles of nearly all the same size or a tight range of particles sizes. The gradation curve for a uniform material is very steep and may be nearly vertical. Another type of gradation important to understand is gap graded. Gap graded materials are missing or have a very small percentage of a range of particles sizes. The result is a gradation curve having a nearly horizontal segment. The horizontal segment results from the missing component of particle sizes. The curve jumps abruptly across the absent range of particle sizes with little change in the percent of material passing (the y-axis).

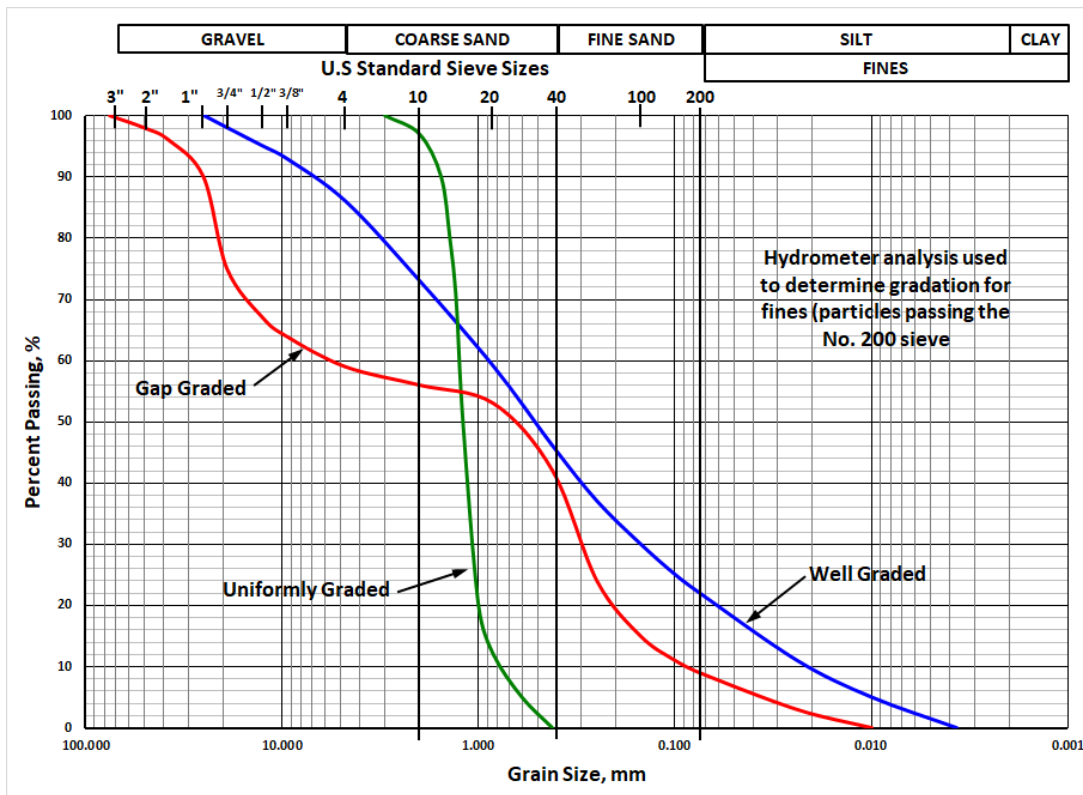

Figure 3.3-1 – Typical Gradation Curves for Various Soil Gradation Types  
Adapted from: Introductory Soil Mechanics and Foundations, Sowers, 4<sup>th</sup> Ed., 1979

Figure 3.3-2 provides some useful visual reference for the three material gradation extremes. Figure 3.3-2(a) provides a very simple but effective visual reference representing the three gradation extremes. Figure 3.3-2(b) provides photos of actual materials representing the three gradations, and Figure 3.3-2(c) provides a schematic representation of the three gradations. A good visual reference of the three gradations is important for understanding the implications of the gradations relative to compaction and material performance.

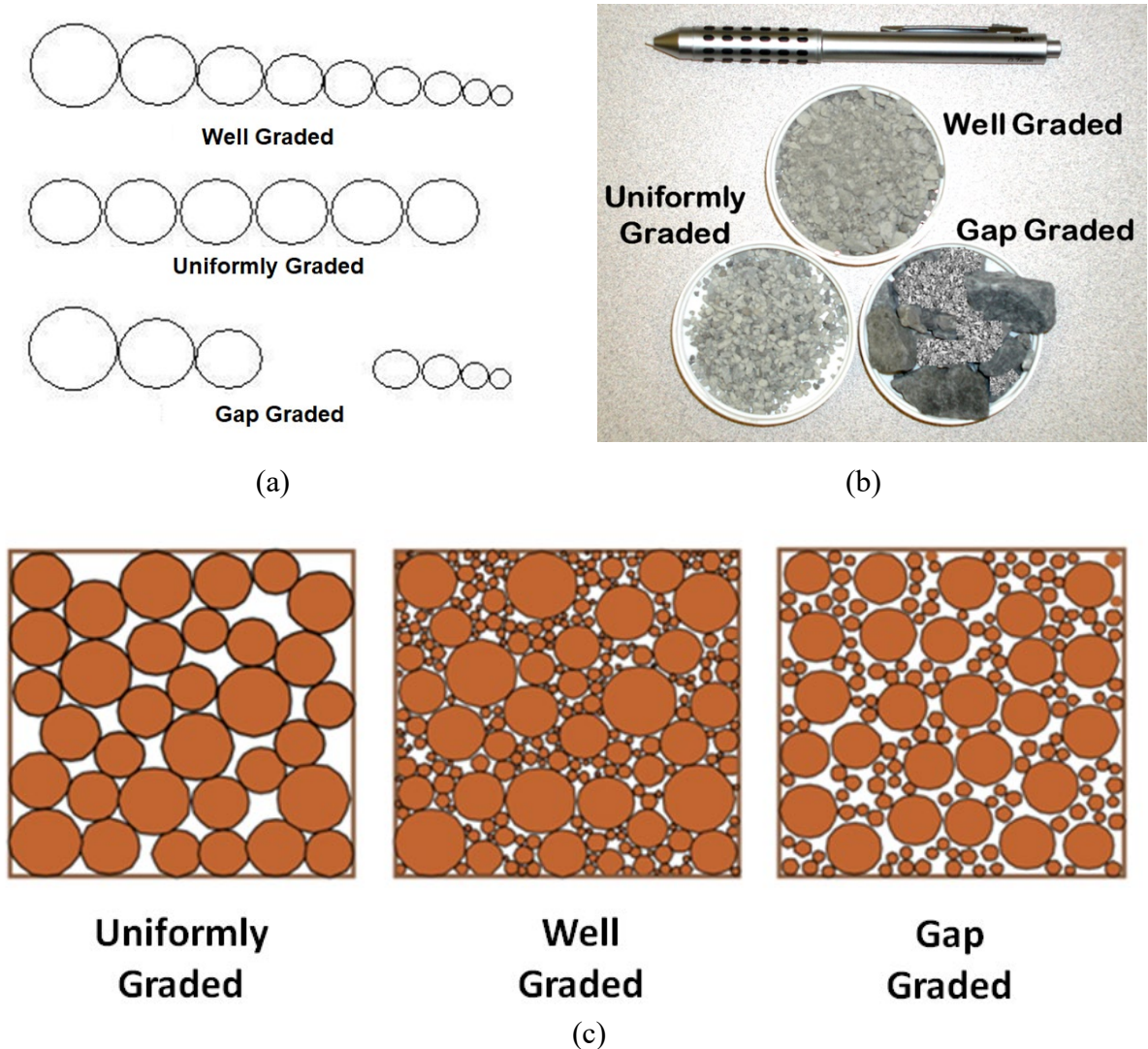

Figure 3.3-2 – Visual References for Various Soil Gradation Types

As indicated, well graded materials are comprised of a broad range of particles sizes and have a long, smooth gradation curve. The particles are well distributed by size and proportioning, and therefore generally compact tightly with smaller particles filling the voids between larger particles. If the material is coarse-grained having only a small fraction of fines (e.g., silts and/or clays), then the use of dynamic vibratory equipment is most effective for compaction. If the material is fine-grained or has an appreciable fraction of fine-grained material (i.e.,  $\geq 20\%$  fines), then static compaction equipment should be used.

Uniformly graded materials are comprised of a narrow range of particles sizes or particles of nearly all the same size. Uniformly graded materials are also termed “poorly graded” (as opposed to well graded). Because they are comprised of a narrow band of particles sizes, uniform gradings can range from very coarse materials to very fine materials (see Figure 3.3-3). While uniform coarse-grained materials (e.g., sands and gravels) can be effectively compacted, they will frequently not appear tight on the surface (due to the lack of smaller particles to fill the voids of larger particles). This often results in the completely false perception or conclusion that such materials cannot be compacted.

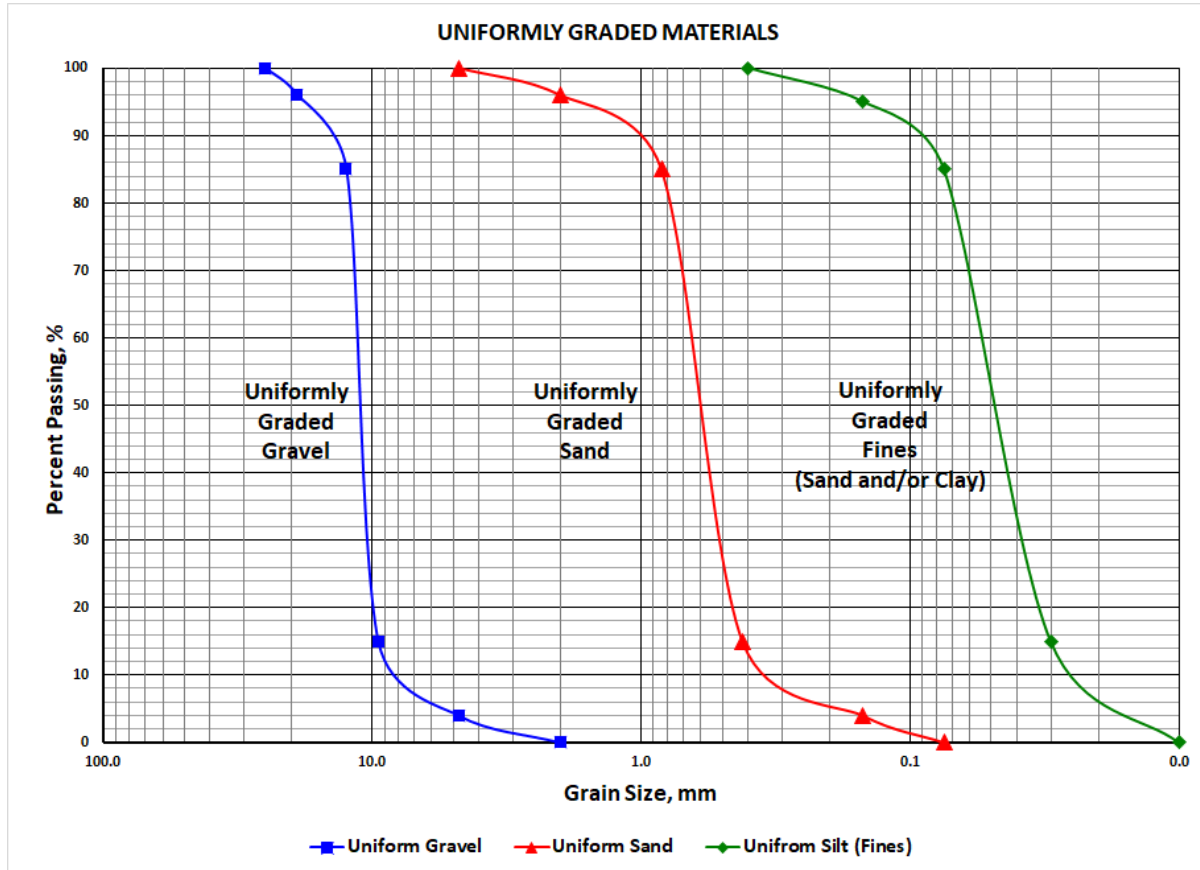

Figure 3.3-3 – Variation in Grain Size for Uniformly Graded Materials

As with well graded materials, uniform coarse-grained materials are compacted with vibratory equipment, and uniform fine-grained materials (i.e.,  $\geq 20\%$  fines) are compacted using static equipment. While graded similarly in that they contain a narrow band of particles sizes, uniform coarse-grained materials behave very differently than uniform fine-grained materials. Uniform coarse-grained materials will be free draining (have higher permeability) and generally exhibit higher shear strengths, than uniform fine-grained materials. Even within uniform fine-grained materials behaviors can vary significantly depending upon plasticity (covered later in Section 3.5). Non-plastic silty soils will behave differently than plastic clayey soils. Plasticity and clay materials will be discussed later in this course, but for now it is important to recognize that silts and clays behave very differently, and as such present different properties and challenges as engineering and construction materials.

As the name implies, gap graded materials are missing a range of particle sizes such that a “gap” in the distribution of particles results. The gap constitutes the absent range of particles sizes and can be seen on a gradation curve as a flat, often nearly horizontal, portion of the curve. It is almost as if two different materials were mixed together, and in terms of performance, that is what frequently results, with the finer component dominating the behavior and properties of the material. Gap graded materials can be susceptible to the migration or loss of the finer fraction of particles sizes with water flows through the material.

When analyzing a gradation curve to assess anticipated material performance and properties, there are three primary features to consider concerning the curve: shape, steepness and location. This is illustrated in the discussions concerning Figures 3.3-1 and 3.3-2 above. The descriptions considering the differences between well graded, uniform and gap graded materials revolved primarily around shape and steepness of the curve, while the differences in the potential types of uniformly graded materials primarily consider location of the curve.

Well graded materials generally have a long, somewhat flat, almost linear gradation curve (shape and steepness). Gap graded materials have a curve with a flat, nearly horizontal component, producing a distinctive hump to the curve (shape and steepness). Uniform materials have a linear, very steep and often nearly vertical curve (shape and steepness), while the position of the curve indicates whether the material is a gravel, sand or is composed fines of silt or clay (location). The position of the curve for well graded and gap graded materials also indicated whether they are dominated by coarse or fine particles (location).

From the discussions above we see that the shape, steepness and location of a materials gradation curve can be a useful indicator of anticipated material characteristics, performance and behavior. Gradation curves can be an indicator of relative strength and relative permeability. A gradation curve indicates the actual particle sizes present in a material, the distribution of individual particle sizes, and the range or relative particles sizes in a material (largest to smallest and their proportioning).

### **3.3.3 Impact of Surface Area**

Particle size is an important contributor to performance because it determines the total surface area of the material mass. Table 3.3-1 indicates the approximate specific surface area (i.e., surface area per cubic foot of material) for various particles sizes. As can be observed, the specific surface area increases drastically as the particles size decreases. Even though the surface area of individual particles would decrease with decreasing particles size, as seen in Table 3.3-1, the number of particles increases rapidly (apparently at a rate much faster than individual particle surface area decreases). There are approximately 8.13 quadrillion ( $8.13 \times 10^{15}$ ) clay size particles in one cubic foot (assuming 20 percent voids), but the one cubic foot volume yields an estimated 21 acres (over 900 thousand sf) of surface area.

Figure 3.3-4 indicates the particle shape used for the analyses in Table 3.3-1, a regular dodecahedron. This shape was selected because its irregular spherical surface more closely matches a natural particle than other geometric shapes of determinant surface area and volume. Figure 3.3-5 shows the relationship between particle size and specific surface area. It can be seen that surface area increases rapidly as particle size decreases. The analyses presented in Table 3.3-1 and Figure 3.3-5 do not consider the actual shape of clay mineral particles. This will be discussed later in this chapter.

Table 3.3-1 – Specific Surface Area (sf/cf) versus Particles Size

Material Description	Particle Size, (mm)	Sieve Size/ Number	Approx. Number Particles per cu. ft. (assume 20% voids)	Approx. Specific Surface Area, (sf/cf) (assume 20% voids)	Comparative Item or Area
Gravel (-3"/+No. 10)	50	2 in	520	37	Sheet of plywood
	25	1 in	4160	74	Small office/cubicle
	12.5	0.5 in	33,300	147	Large office
	4.8	No. 4	588,000	384	Large deck
Coarse Sand (-10/+40)	2.0	No. 10	8,130,000	981	One bedroom apartment
Fine Sand (-40/+200)	0.42	No. 40	878 million (878 x 10 <sup>6</sup> )	4380	Large house
Silt (-200/+0.002mm)	0.075	No. 200	154 billion (154 x 10 <sup>9</sup> )	24,500	One half of a football field
Clay (-0.002 mm)	0.002		8.13 quadrillion (8.13 x 10 <sup>15</sup> )	921,000	21 acres (over 3 Nimitz Class Aircraft Carriers)

Note: Particle shape is a regular dodecahedron to more closely match irregularities of a natural particle (see Figure 3.3-4)

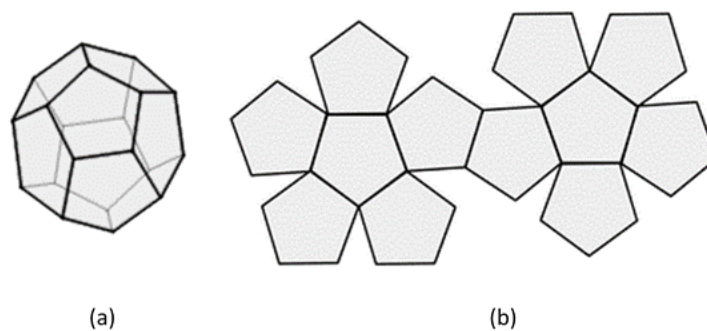

Figure 3.3-4 – (a) Regular Dodecahedron, (b) Unfolded dodecahedron – 12 sided with pentagon faces



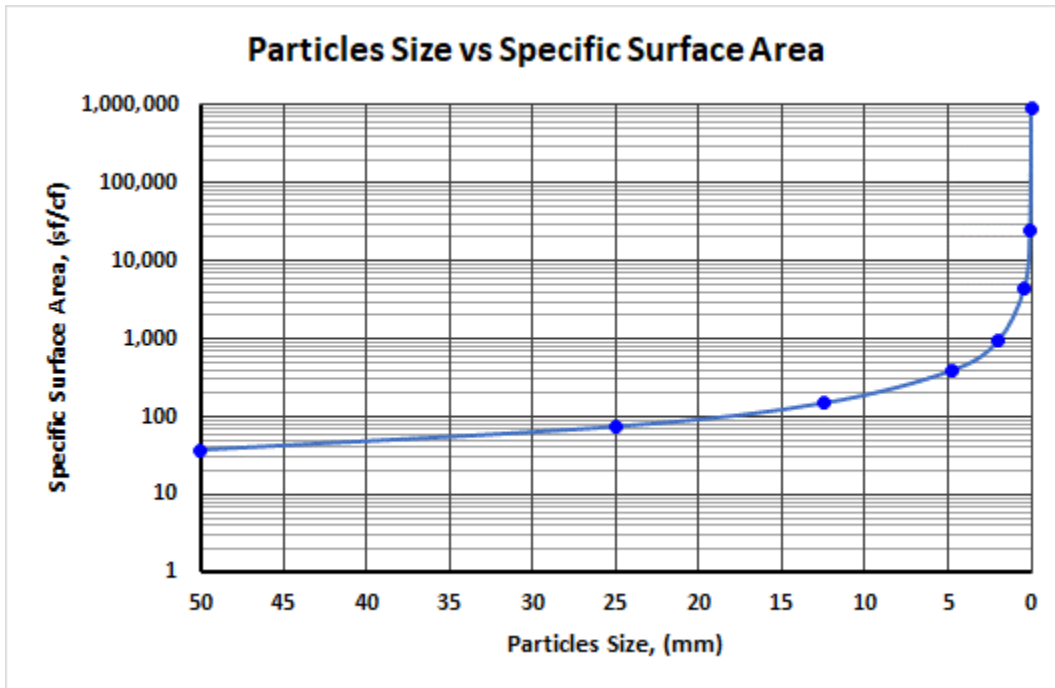

Figure 3.3-5 – Specific Surface Area versus Particle Size

Recall that soil is composed of a combination of solids, air and water. As particle size decreases and surface area increases, the amount of natural moisture retained by a soil, increases. Figure 3.3-6 depicts the water film around particles for several assumed conditions. The figure uses a random assumed particle shape. The basic shape is retained for all three cases (Figure 3.3-6a, -b and -c), with orientation of the particles varied between Figure 3.3-6a and -b, and both particle size and orientation varied in Figure 3.3-6c. The area within the solid border around each of the figure components (a, b and c) is the same.

Figure 3.3-6a models a material with uniform particles prior to compaction, while Figure 3.3-6b models the same material after the particles have been reoriented by compaction. Note the reduction in void space. The reorientation of the particles reduced void space by eleven percent (the area between the solid and dashed lined borders). Note also the increase in particle contact area. The increase contact area and increase in particle to particle stress from being pushed tighter together by the compaction force, results in a significant increase in shear strength for the material in Figure 3.3-6b.

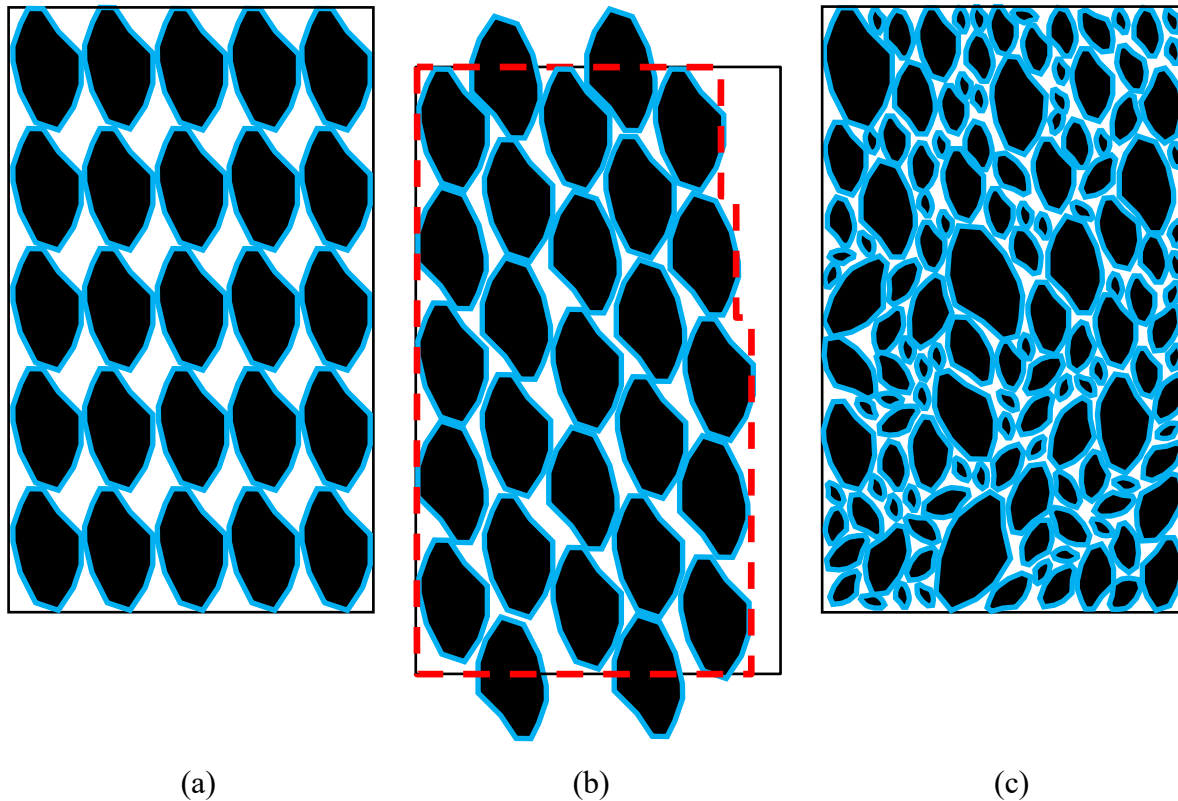

Figure 3.3-6 – Relationship between particle size, surface area and moisture content

Now reference Figure 3.3-6c. The particles are all the same shape but are of different sizes. There are five different particle sizes, with the smallest particle proportioned at 20 percent of the largest particle, and the particles sizes in between proportioned in 20 percent steps. Note that as particle size decreases, there are proportionally more smaller particles than larger particles, but the total of each represents approximately the same total area. (Recall from Table 3.3-1 above that there are many more small particles per unit volume than large particles). This is consistent with a well graded material. Note also the further decrease in void space, the increase in particle contact surface area, and the increase in the area of water film and therefore, moisture content. As specific surface area (i.e., surface area per unit volume) of a material increases, the moisture content increases.

Water has a major impact on the performance of soil, especially soil shear strength. In Figure 3.3-5 the impact on shear strength in each of the three cases is minimal, since none of the three materials are saturated, creating excess pore pressures, and reducing the effective stress between material particles. Water is incompressible and if a saturated condition develops (i.e., all voids occupied by water), the water will act to push the particles apart, reducing the stress between the grains, resulting in a reduction in material shear strength.

### 3.4 Mineralogy – Clay Minerals

In the previous section, while the individual particles may adsorb some water due to porosity of the grains, they do not interact in any significant way (relative to material behavior) with water at the molecular level. While that is the case for most earth materials, there is a specific class of earth material that has a high affinity for water. These are known as clay minerals.

While the term “clay” is attributed to any particle having a size less than two microns (0.002 mm), clay minerals are of a specific type of chemistry and have a crystal structure. Clay minerals generally form as the result of weathering of rock in the presence of water. Clay minerals have range of particle sizes and while they can be larger than two microns, they are generally very small. Water is strongly attracted to the surface of clays minerals and they have a very high specific surface area (i.e., high surface area per unit volume). The high specific surface area of clay minerals is a result of their structure. The structure of some typical clay minerals can be observed in Figure 3.4-1.

As can be observed in Figure 3.4-1, clay minerals consist of a typically very small (4 to 5 microns), sheet like structures, that are extremely thin (roughly 7 angstroms or approximately 0.0007 microns). By comparison, a single water molecule has a diameter of approximately 3 angstroms. Observing these dimensions and structure, the extremely high specific surface area of clay minerals becomes readily apparent.

Table 3.4-1 is an updated version of Table 3.3-1, with the bottom row added for clay minerals (in addition to what is defined as a clay size particle at less than 0.002 mm). Accounting for the sheet like structure of clay minerals, the approximate number of clay mineral particles versus clay size particles per cubic foot of volume (assuming 20 percent voids) increases from 8 quadrillion to 698 quadrillion. The specific surface area increases from 921,000 sf/cf for clay size particles, to 244 million sf/cf for clay mineral particles (again assuming 20 percent void space). The surface area of one cubic foot of clay mineral particles is equivalent to approximately 4900 acres or 8 square miles. For purposes of comparison, this roughly the area of the city of Harrisburg, PA, 4.5 times the combined areas of Disney World’s four major theme parks, or 4000 football fields. Note that there are a variety of clay minerals with varying physical properties.

As Table 3.3-1 was updated for the impact of clay minerals, so to is Figure 3.3-5 showing the relationship between particle size and specific surface area. Figure 3.4-2 is an update of Figure 3.3-5 indicating the impact of clay minerals on specific surface area. Considering clay mineral particles, the maximum specific surface area increases from less than one million sf/cf for a clay size particle to over 200 million sf/cf for a clay mineral particle.

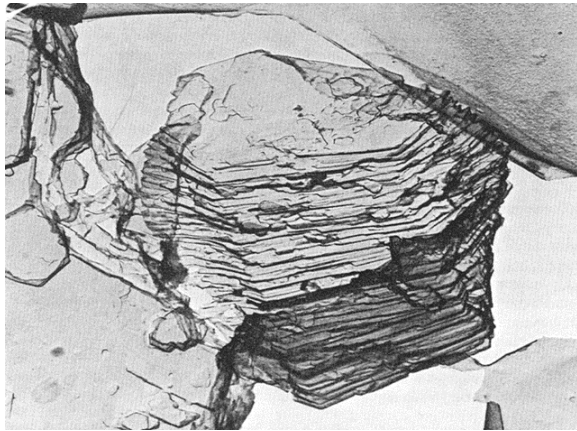

Photo Source: Introductory Soil Mechanics and Foundations, Sowers, 4<sup>th</sup> Ed., 1979

(a)

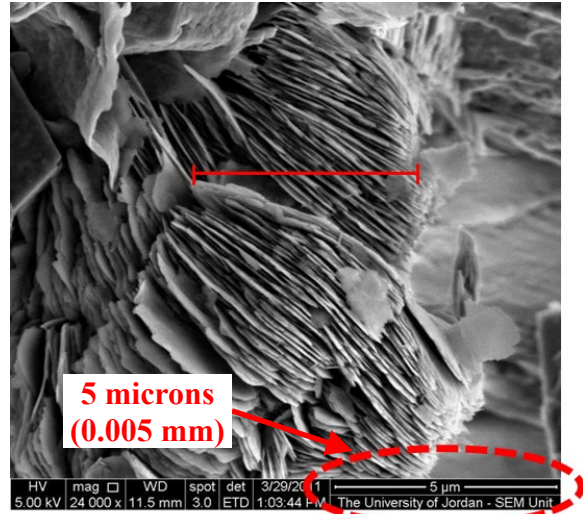

Photo Source: [https://www.flickr.com/photos/fei\\_company/5643602139/in/photostream/](https://www.flickr.com/photos/fei_company/5643602139/in/photostream/)

(b)

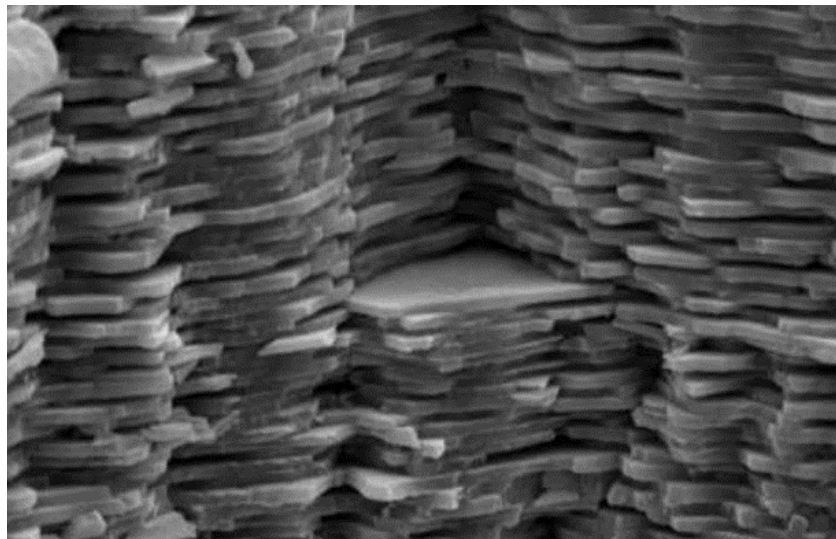

Photo Source: Unknown

(c)

Figure 3.4-1 – Micrographs of Various Clay Minerals

The physical properties for clay minerals in the discussion above are typical for a variety of clay mineral known as Kaolinite which is common in Pennsylvania soils. Another clay mineral common in Pennsylvania is Illite. Illite has a specific surface area six times that of Kaolinite (see Figure 3.4-2). Montmorillonite (a type of Smectite that is also referred to as Bentonite) has a specific area over fifty times than of Kaolinite and is highly adsorptive of water, so much so that it is prone to swelling.

Table 3.3-1 – Specific Surface Area (sf/cf) versus Particles Size

Material Description	Particle Size, (mm)	Sieve Size/ Number	Approx. Number Particles per cu. ft. (assume 20% voids)	Approx. Specific Surface Area, (sf/cf) (assume 20% voids)	Comparative Item or Area
Gravel (-3"/+No. 10)	50	2 in	520	37	Sheet of plywood
	25	1 in	4160	74	Small office/cubicle
	12.5	0.5 in	33,300	147	Large office
	4.8	No. 4	588,000	384	Large deck
Coarse Sand (-10/+40)	2.0	No. 10	8,130,000	981	One bedroom apartment
Fine Sand (-40/+200)	0.42	No. 40	878 million (878 x 10 <sup>6</sup> )	4380	Large house
Silt (-200/+0.002mm)	0.075	No. 200	154 billion (154 x 10 <sup>9</sup> )	24,500	One half of a football field
Clay (-0.002 mm)	0.002		8.13 quadrillion (8.13 x 10 <sup>15</sup> )	921,000	21 acres (over 3 Nimitz Class Aircraft Carriers)
Clay Mineral Particle	0.005 mm x 0.005 mm x 0.0000007 mm		610 quadrillion (610 x 10 <sup>15</sup> )	213,000,000	4900 acres (approx. 8 sq. miles – roughly area of city of Harrisburg)

- Notes: 1) Particle shape is a regular dodecahedron (except for clay mineral) to more closely match irregularities of a natural particle  
 2) Clay mineral is flat particle of dimensions indicated  
 3) 0.0000007 mm = 7 angstroms  
 4) Diameter of water molecule is approximately 3 angstroms

Not only is the specific surface area of clay minerals extraordinarily high, but as indicated, clay minerals have a high affinity for water. The mechanism of attraction of clay minerals to water is not well understood but is thought to be an electrical attraction between the clay mineral and water at the molecular level. Spacing of clay minerals is approximately 10 angstroms with a particle thickness of approximately 7 angstroms, leaving a 3 angstrom gap – the approximate diameter of a water molecule. Water molecules are adsorbed (versus absorbed) by bonding to the surface of the clay mineral particles.

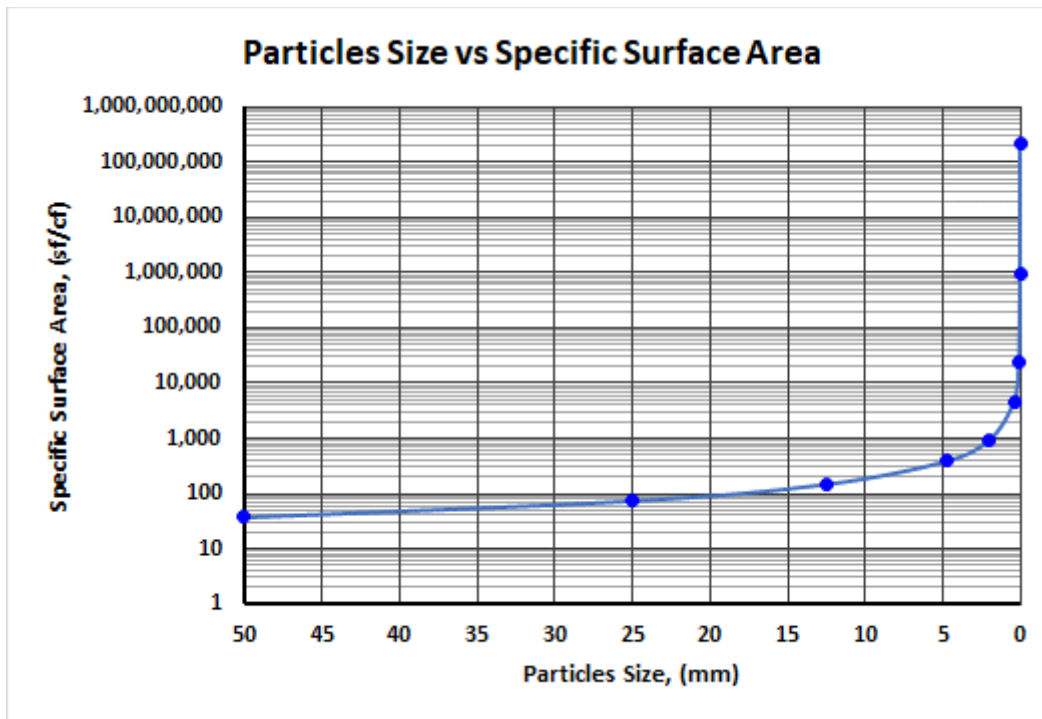

Figure 3.4-2 – Specific Surface Area versus Particle Size with Clay Mineral Particles

Table 3.4-2 – Specific Surface of Various Clay Minerals

Mineral	Specific surface (m <sup>2</sup> /g)	C.E.C (meq/100g)
Kaolinite	10-20	3-10
Illite	80-100	20-30
Montmorillonite	800	80-120
Chlorite	80	20-30

Source: Presentation – Clay Mineralogy by Dr. Hassan Harraz, Department of Geology, Tanta University, Egypt

While the frictional component of soil shear strength is dependent upon the stress condition (i.e., the overburden or confining stress), as observed in the equation, cohesion is completely independent of stress. However, cohesion is highly dependent upon moisture content. As moisture content increases, the amount of water between clay particles increases. The source of cohesion the attractive forces or bonds between water molecules and the adjacent clay surface. As the thickness of the water layer between clay particles increases and the clay particles separate, the attractive forces weaken similar to how the attraction force between magnetics weakens or decreases as the gap between magnets increases.

Water molecules are bonded to the surface of the clay mineral particles. Added layers of water are held much more weakly, and cohesion decreases. Therefore, cohesion, and total soil shear strength, decreases as water content increases. The implication and functional consequence of the structure of clay minerals, and their affinity for water, is simple yet highly significant: “A very small percent of clay mineral in a soil mass, can have a very large and significant impact upon soil properties, behavior and performance.”

### **3.5 Shear Strength and Behavior of Soil Masses**

Generally speaking, soil mass behavior can be divided into two broad categories:

- 1) Granular or Cohesionless Soils
- 2) Cohesive or Plastic Soils

The two broad categories each have specific performance and behavioral characteristics, and some significant performance and behavioral differences.

Granular or cohesionless soils are coarse-grained including sands and gravels. They are sometimes referred to as “ $\phi$ ” or “ $\phi$ ” soils since they do not exhibit any cohesion. They get their strength solely from friction. They do not hold their shape when molded (except for finer sands that exhibit weak apparent cohesion when moist from capillary tension – this is lost when the material dries out, and the material crumbles easily, often under its own weight). Granular cohesionless soils are typically more free draining (i.e., have higher permeability), and generally less moisture sensitive.

At the other end of the soil behavioral spectrum are fine-grained cohesive or plastic soils. These consist of clays (high clay mineral content soils) or fine-grained soils with adequate clay mineral content. Finer sands containing an adequate content of clay mineral particles can behave as substantially cohesive or plastic soils. Cohesive soils are often referred to as plastic soils. They can be molded when moist, easily holding their shape and easily supporting their own mass, even when they dry out. This “moldability” is the source of the term “plastic” soil. They behave much like a plastic. They get their strength predominantly from cohesion, accounting for their plastic behavior, and are sometimes referred to as “c” soils.

While the above two material types represent the two ends of the spectrum for soil characteristics and performance, to some degree, more typical soil masses exhibit characteristics of both types of materials. Most soils are a mix of particle sizes having both granular and cohesive components, exhibiting behaviors of both soil types. These are frequently referred to as “c/ $\phi$ ” soils. Such materials exhibit shear strength from a combination of friction and cohesion. Depending upon the soil fractions present and the mineralogy, specifically the clay mineral content, the soil mass may lean more heavily towards granular or cohesive behavior.

#### **3.5.1 Cohesionless Soils – Friction**

As indicated, granular (cohesionless) soils obtain shear strength from internal friction between soil particles. Friction is a mechanical property that develops because of frictional forces resulting from resistance between soil particles. The mechanics of these forces may be in part due to adhesion but are likely primarily the result of interlock of asperities. Asperities are

small irregularities that result in an “unevenness” or “roughness” of a surface. Figure 3.5-1 represents that relative asperities of different grades (grits) of sandpaper.

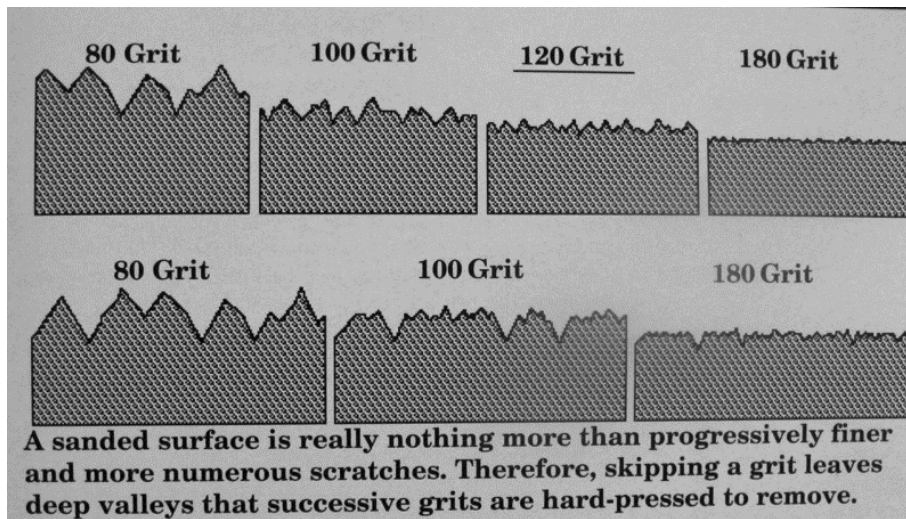

Figure 3.5-1 – Asperities for various grades of sandpaper, Coarse to Fine Grit

Source: <http://www.briwax-trg.com/How%20to%20Use%20Briwax/Sanding%20Before%20Using%20Briwax/sandingbeforeusingbriwax.html>

As the sandpaper becomes progressively finer, the degree of the surface irregularities becomes progressively less pronounced. The surfaces of soil particles have asperities that result in a degree of interlock between adjacent particles. The soil shear strength resulting from these asperities is a function of three factors: the interparticle stresses, the size or the asperities and the strength of the individual particles.

As discussed previously, the frictional component of the shear strength equation is a function of the stress between particles of a soil mass and the friction angle between the particles. Without interparticle stress, the friction between particles cannot be mobilized. Similarly, without surface asperities there will be little friction between the particles. The greater the size of the asperities, the higher the potential friction angle. The term potential is used because of the final of the three factors – the strength of the individual particles. If the particles themselves are very weak, the particles will fail by shear across or through the asperities when sufficient stress is applied. However, in most soil masses, the soil particles have sufficient strength to prevent internal particle shear failure, and the degree of asperities and magnitude of the interparticle stress dictates the frictional component of shear strength.

The role of asperities in contribution to soil shear strength cannot be understated. Surface asperities occur even at a microscopic level, and even at this scale contribute significantly to soil shear strength. Figure 3.5-2 are photographs of various items at 40x magnification.



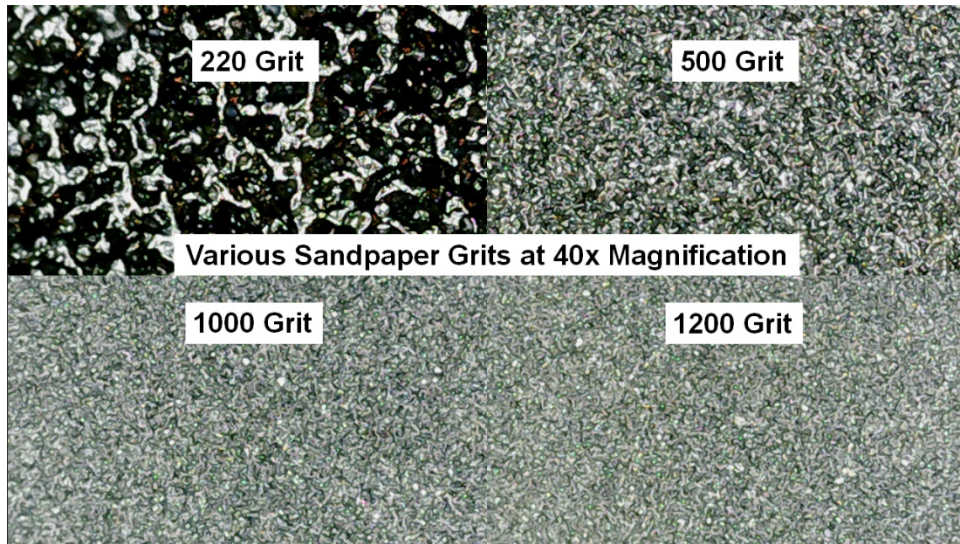

(a)

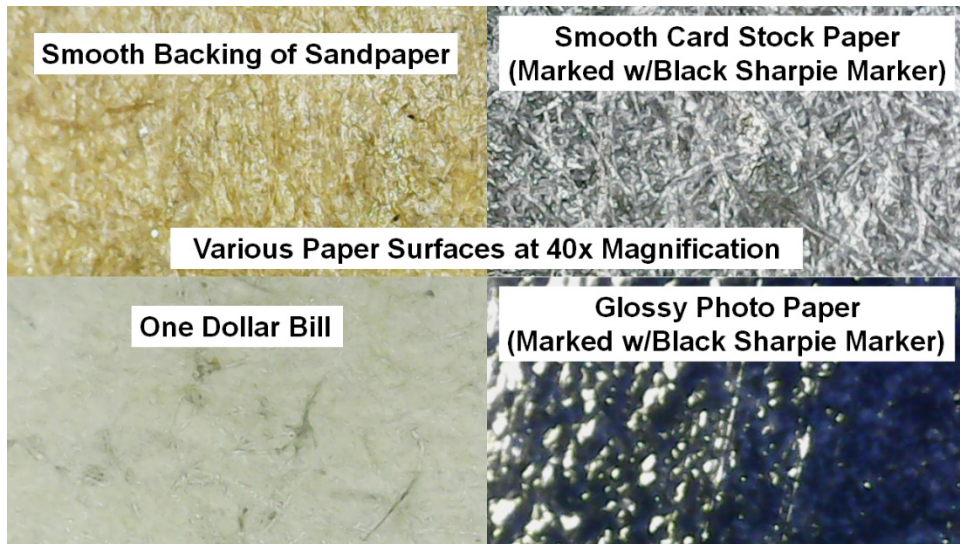

(b)

Figure 3.5-2 – Various Surfaces at 40x Magnification, (a) Various Grit Sandpapers, (b) Various Paper Surfaces

Figure 3.5-2(a) is the surface of various grit sandpapers at 40x magnification. All sandpaper materials were comprised of a black grit material so that shading from external lighting enhances the visibility of the asperities. The asperities for the 220 grit sandpaper are readily apparent. For reference, a 220 grit sandpaper is typically used as a grade to prepare wood surfaces for the application of finishes (e.g. polyurethane coatings). At the 500 size grit, the asperities are less easy to recognize and start to appear more as a texture. For the 1000 and 1200 grit levels at 40x magnification, the asperities are reflected completely as a difference in texture. However, because of the side lighting, the texture is indication of the surface irregularity. For reference, a 1200 grit sandpaper is used to produce an extremely smooth surface on harder materials such as metals, or in initial steps of polishing hard surfaces. The average particle

diameter of 220 size grit is 68 microns, and the average particle diameter of 1200 size grit is 18 microns (1 micron = 0.001 mm).

Figure 3.5-2(b) is the surface of various common paper materials under 40x magnification. Of particular interest are the 3x5 index card (smooth card stock paper) and the glossy finish photo paper. Both were mark with a black ink to enhance the asperities in cross lighting. The apparent roughness and irregularities of the paper fibers are readily visible. More surprising are the asperities visible at 40x magnification for the glossy finish photo paper – a seemingly very smooth surface.

A very simple experiment can be conducted to understand the roles of stress (i.e., overburden pressure) and asperities in developing the friction component of soil shear. Take a sheet of plain paper and place it on a smooth table surface. Because of the asperities in both the surfaces of the paper and the table, there is friction between them. Yet the when grabbed, the paper can easily be pulled across the table surface. Now, with the paper still lying on top of the table, take your other hand and press down on top of the paper. Now try to pull the paper. It is likely that you can apply enough pressure on top of the paper so that you would tear the paper with the other hand before you be able to pull the paper across the table surface. This is a simple demonstration of the mobilization of friction by the application of normal stress (i.e., stress applied perpendicular to the paper surface). This is exactly how the frictional component of soil shear strength is developed.

### **3.5.2 Cohesive Soils – Cohesion**

Fine-grained plastic soils (i.e., cohesive soils) obtain shear strength from cohesion between soil particles. The property of cohesion and cohesive forces are not well understood but are thought to develop from electrostatic forces from bonding at the molecular level. The magnitude or strength of the cohesive force will depend upon three factors: 1) the type of clay mineral(s) present in the soil mass, 2) the percent of clay minerals present in the soil mass, and 3) the moisture content.

The term plastic has been used above. It is the property that a soil can be molded and retain its shape without aid of any external forces, bracing or support. Plasticity is an indicator and function of cohesion and the result of clay minerals present in the soil. However, like any plastic, while it can retain its shape, it can also very slowly yield or creep under sustained long term loads.

In a lab, soil plasticity (Plastic Index or PI) is measured as the difference between a soils plastic limit (PL) and Liquid Limit (LL). In equation form,  $PI = LL - PL$ . The plastic index is the measured liquid limit value minus the measured plastic limit value. Plastic limit and liquid limit are both standard laboratory standard test procedures. All three values (LL, PL and PI) are expressed as soil moisture contents in percent.

The plastic index (often termed plasticity index) is simply a measure of the range of moisture contents over which a soil behaves in a plastic manner. The range of moisture contents over which a soil can be molded as a solid mass and retain its shape. Below the plastic limit, the material will start to break apart and crumble. Above the liquid limit, the material will start to

flow and behave more like a viscous fluid. Between the plastic and liquid limits, the material will behave in a plastic manner.

Regardless of its specific relation to plastic or liquid limit of a given soil, as moisture content of a plastic soil increases, the cohesion, and therefore, total shear strength of the soil, decreases (see Figures 3.5-3 and 3.5-4). Increases in moisture to a plastic soil will always reduce shear strength. However, the relationship is not linear, and varies with clay mineral type and content. As a result, the values of plastic and liquid limit, and plasticity index, will impact the relationship of moisture content to shear strength of plastic soils. This is not to imply that a certain level of moisture and plasticity cannot be beneficial during compaction. As we will see, there are some conditions and soil types where an acceptable level of soil plasticity in fine-grained soils can be highly beneficial.

**(It should be noted that the observed thresholds, as set by the standard laboratory test methods, at which a soil is defined as behaving plastic and liquid, are somewhat arbitrary. Further discussion of these definitions are beyond the scope of this document, however, even though they are somewhat arbitrary, the usefulness lies in that the two values are defined in exactly the same manner for all materials. This provides a useful and valuable baseline in defining the nature of the material and its anticipated behavior relative to other soil materials.)**

### **3.6 Field Testing of Fine-Grained Soils – Plastic versus Non-plastic Materials**

While many soil masses exhibit a combination of frictional and cohesive strength components, it is useful, and very easy, to determine if the specific material at hand is cohesive, cohesionless or some combination. This is especially important for fine-grained soils or soils containing at least 20 percent fines (i.e., 20% passing the No. 200 sieve) since the fines will dictate the behavior of the material.

There is a field test that can provide a rough estimate of the percentage of fines in a soil sample. The field sedimentation test, also called the jar test, separates a soil sample by grain size, allowing for a rough estimate of the soil gradation. All that is needed to conduct this test is a clear glass jar with a fitted lid, clean water, and a representative soil sample. Fill a quarter of the jar with the soil sample. Pour water into the jar until it is roughly three quarters full. Secure the lid and shake vigorously until all the soil clumps have broken up. Place the jar on a level surface and allow the particles to settle. The particles will settle according to size, the larger the particle, the sooner it settles. Any gravel present in the sample will be located on the bottom of the jar, followed by sand, silt and finally clay. The stratification of these layers will be visible to the eye, allowing for an approximate soil gradation. This test is useful for a quick interpretation of the soil behavior, if it is fine-grained or course-grained, but it will not necessarily indicate the level of plasticity.

In the field, it is very easy to determine and observe if a fine-grained soil exhibits plasticity and therefore, cohesive behavior. Four very simple tests can be conducted in the field to assess the nature of the finer fraction of the soil mass. These tests include the field plasticity test, the “marble” dry strength test, the “marble” slake test and the dilatancy test. It is

recommended that all four tests be conducted to obtain the best indication as to the level (if any) of cohesion and cohesive strength a soil exhibits.

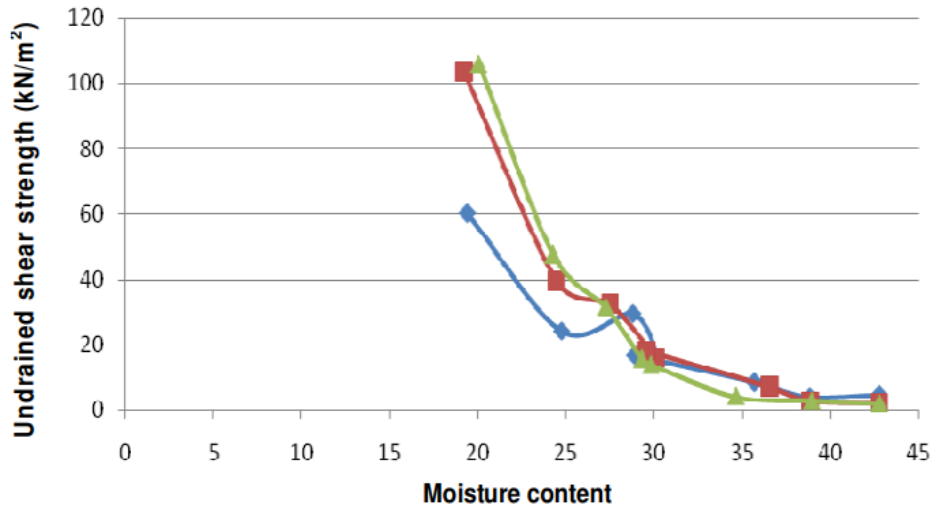

Figure 3.5-3 – Undrained Shear Strength vs. Moisture Content at Varying Compactive Efforts

**(Note: Undrain Shear Strength ( $S_u$ ) =  $\frac{1}{2}$  Cohesion (c) or  $S_u = 0.5c$ )**

Source: Effect of soil moisture in the analysis of undrained shear strength of compacted clayey soil, Rohit Ghosh, Department of Construction Engineering, Journal of Civil Engineering and Construction Technology, Vol. 4(1), pp. 23.31, January 2013.

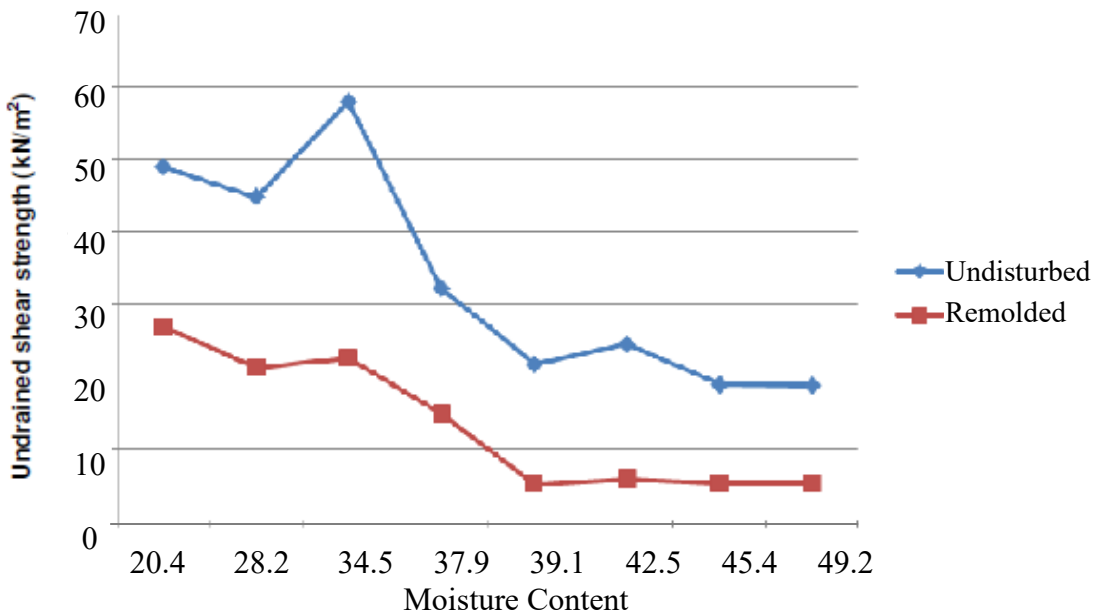

Figure 3.5-4 – Undrained Shear Strength vs. Moisture Content for an Undisturbed and Remolded Clay

All that is necessary is to perform a simplified version of the lab plastic limit test, is a sample of the finer fraction of the soil. The sample can consist of material passing the No. 40 sieve (the threshold for fine sands). Since a sieve is generally not readily available in the field, and it is not necessary that the material be exactly passing the No. 40 sieve, any sample of the soil in question will be adequate so long as the following criteria are met: reasonably free of coarse sand particles, consists predominantly of fine sand and fines, and is representative of the material to be evaluated. If the material is too dry, a source of water is also required (very little water is needed). The actual plastic limit will not be able to be quantified, but identifying as to whether the material exhibits plasticity can be readily determined.

If the soil is mix grained having a substantial component of coarse sand and gravel, it will be necessary to remove the coarse particles, if possible, isolate a sample with the mass substantially free of coarse material, or go to the toe of a slope or other area where the flow of surface water has already separated the coarse and fine particles. In the latter case, be very careful to make sure that water has not carried away the very fine clay mineral particles and that only silt fines and fine sands were left behind. Check the material consistency against an “unsorted” sample of material from the mass in question. If clay fines have been carried away, the sample will result in a false indication of whether the material is plastic. To obtain a water separated sample, obtain the sample from a closely located low velocity terminal drainage location, where all soil fines have been able to slowly settle out of suspension from the flowing water.

Once a suitable sample has been located and obtained, attempt to roll the fine material between the palms of your hands. If the material is very wet, you may have to work the material rolling between your palms to reduce the moisture content. If the material is too dry, a very small amount of water will have to be added to the sample. A highly plastic material may be too “sticky” to roll at higher moisture contents. Just keep working the soil between your hands to dry it out. This applies to any soil that is too wet to roll between the palm of your hands.

Once the sample is workable, and does not stick excessively to the palms of your hands, attempt to roll the material into a ribbon. If the material is plastic, you will be able to easily roll a ribbon of 1/4 - to 1/8 - inch diameter between your palms. A non-plastic material will start to crack and crumble around 1/4 - inch diameter (or larger). See Figure 3.5-4 for photo examples of plastic and non-plastic soils rolled between the palms. Soil that exhibits plastic behavior (can be rolled into thin ribbons approximately 1/8 - to 3/16 - inch diameter) will exhibit cohesion and have a cohesive component of shear strength.

The second test is the “marble” strength test. Again, obtain a representative sample of the soil in question as described above for the field plasticity test. Again, add a small amount of water to the sample if necessary. Next roll the sample between the palms forming as round a ball as possible. Use sufficient soil to form a ball between 5/8 - and 3/4 - inch in diameter that resembles a marble. If the ball is too wet (will not sufficiently hold its shape under its own weight), just keep rolling between the palms to sufficiently dry the soil.



Photo Source: <https://www.aboutcivil.org/to-determine-liquid-limit-plastic-limit-of-soil.html>

(a)



Photo Source: [https://www.nrcs.usda.gov/wps/portal/nrcs/detail//?cid=nrcs142p2\\_026828](https://www.nrcs.usda.gov/wps/portal/nrcs/detail//?cid=nrcs142p2_026828)

(b)

Figure 3.5-4 – Examples of field test for plasticity on (a) plastic and (b) non-plastic materials

Once a ball of the desired size can be formed that can be placed on a hard surface without sagging excessively (the ball remains close to a sphere shape), the sample is ready. Place the sample aside where it can be permitted to dry undisturbed. Somewhere warm or in the sun is desired as it will speed up the drying process. If it is cold or damp outside, place the sample indoors to dry, if possible, or in a heated vehicle. Allow the sample to completely dry out. Depending upon the temperature and humidity, this may take several hours. Make several of these specimens since the same sample size and preparation procedure will also be used for the “marble” slake test.

In preparing the samples for testing, there are a few other distinguishing characteristics between plastic and non-plastic soils that can be easily observed in the field. Because of clay minerals affinity for water, the more clay a material contains, the longer it takes to dry. As a result, non-plastic silt fines tend to dry much more rapidly than highly plastic clay fines. This can often be observed on the skin when preparing the samples. Silts will dry more rapidly and form a loose powder like coating when they dry that can easily be dusted off. When the soil “marbles” have completely dried (again, low to non-plastic silt material will tend to dry out faster than a clayey material), the strength and slake tests can be performed.

First take one of the marbles and rub it lightly across one of your fingers. If the sample leaves a distinct powdery residue, this is a strong indication the material is non-plastic and consists of clean silt fines (i.e., very little to no clay minerals present). Next take one of the prepared soil marbles and attempt to crush it between your thumb and index finger. If the sample crushes easily, it is likely a clean non-plastic silt (i.e., very little to no clay and essentially no cohesive strength). If the sample can be crushed between the thumb and index finger with

great effort, it is likely that the material is of low plasticity (i.e., the material exhibits a small amount of plasticity, likely has some clay and likely exhibit a little bit of cohesive strength).

If the sample cannot be crushed between the thumb and index finger, place the marble on a smooth hard surface and attempt to crush the sample with a hammer or a smooth palm size rock. It is important that both that “hammer” and “anvil” surfaces be smooth to avoid any point loads that may produce misleading results. Attempt to crush the sample with the hammer or smooth rock with light blows. Continue increasing the force of the blows until the sample crushes. The greater the force required to crush the sample, the higher the material plasticity and higher potential cohesive component of shear strength.

Soil marbles consisting of low to non-plastic silts will break with little force. The more plastic and clayey the material the greater the force required to crush the soil marble. The dry strength of plastic soils (i.e., clays) is much higher than the dry strength of non-plastic soils (i.e., silts). Also, when the marble is broken, non- to low-plastic materials will form more powder than higher plastic soils. Table 3.5-1 provides some guidance in assessing the material plasticity based upon dry strength and powdering. Understand that it is a non-exact qualitative tool to assist in estimating and understanding soil behavior. User base knowledge and experience may impact interpretation.

Table 3.5-1 – Assessing Soil Plasticity Based Upon Dry Strength and Powdering				
Dry Strength	Powdering	Plasticity	Possible Soil Classifications	
			AASHTO	USCS/ ASTM
Very Low – can be crushed with ease	Powders when handled and powders when crushed	Non-plastic	A-4, A-5, A-2-4, A-2-5	ML, MH, OL, OH
Low – can be crushed with moderate pressure	Some powdering	Slight to Low Plasticity	A-4, A-5, A-2-4, A-2-5	ML, MH
Medium – can be broken with great effort	Low to no powdering	Medium Plasticity	A-6	CL
High – can be broken with light blows of hammer or rock	No powdering	High Plasticity	A-6, A-7-6	CH
Very High – can be broken with moderate blows or repeated light blows of hammer or rock	No Powdering	Very High Plasticity	A-7-6	CH

The next test is the “marble” slake test. Set up a shallow pan of clean water. Place a couple of the dried soil marbles gently in the water on the bottom of the pan. Leave the marbles in the pan undisturbed. Observe what happens to the marbles. Non-plastic materials will very

rapidly start to slake or disintegrate in the water. Within several minutes the “marble” will disintegrate into a small mound of soil. As the plasticity of the material increases, the time for the sample to breakdown increases. If undisturbed, highly plastic soils can sit in the pan for hours with little change except a soft slick outer surface.

Finally, there is the soil dilatancy test which is sometimes referred to as a shake test. Obtain a soil sample as described above for the other field tests. The sample should be about the size of a lemon (it should just about, but not quite, fit inside your hand when squeezed). The soil should be moist – more than damp but not wet. Start with the sample in approximately the shape of a ball or lemon. Hold the sample in the palm of your hand and start shaking the sample horizontally very rapidly. Observe what happens to the sample when shaking.

Observe if water comes to the surface when shaking and the sample takes on a glossy, wet appearance. Observe if the sample starts to slowly flow and flatten out like a viscous fluid. If the sample softens and takes on a glassy appearance, squeeze the sample and observe what happens. If the reactions described above occur, note how fast the reactions appear after the start of shaking and after squeezing.

If water rapidly appears on the surface and the sample quickly starts acting like a viscous fluid, and then the glassy surface quickly disappears when the sample is squeezed, the material is non-plastic. If water does not appear on the surface of the sample, the material is plastic. If there is a slow or slight reaction, it is an indication of very low or slight plasticity.

### **3.7 Non-plastic Silts**

There is another type of soil that fits into a specific AASHTO classification that is important to discuss. It is important not only because it is very common in Pennsylvania, but more importantly, because it is an especially difficult material to work with relative to compaction. The AASHTO classifications are A-4 soil and A-2-4 soil with at least 20 percent fines. This material contains a high percentage (i.e., minimum 35% and 20%, respectively) of low to non-plastic fines (i.e., material passing the No. 200 sieve).

The non-plastic fines are silts. Silts exhibit low permeability resulting in poor drainage performance, but also lack plasticity that would provide cohesive binding. Relative to compaction, high silt content materials (i.e., 20 percent or more fines), with no plastic fines component (i.e. no clays), are the most difficult materials to work with. They are frequently moisture sensitive – small changes in moisture content result in large changes in dry density. The low permeability results in poor dissipation of internal pore pressures due to compaction. The resulting excess pore pressures push soil particles apart and with the lack of any cohesive binding the materials easily become unstable, especially if vibratory compaction methods are used.

It is important to recognize that soil fines are very significant relative to the behavior and performance of a material. Some fines are plastic, and some are non-plastic. Both the fines content (i.e., % fines) and the nature of the fines (i.e., plastic vs. non-plastic) are important in assessing anticipated material behavior. This is because the fines content of a soil will always



disproportionally control the strength, behavior and performance of the material. When it comes to soil properties, a little bit of fines goes a long way.

## **Chapter 4 – FUNDAMENTALS OF COMPACTION**

### **4.1 Moisture-Density Testing**

The fundamentals of compaction control were developed by a man named Ralph R. Proctor. Proctor was a civil engineer with the Los Angeles Department of Power and Water (LADPW) was heavily involved in dam construction. He developed the “Proctor Test” or Moisture-Density (M-D) relationship of soils in 1933 while working on the Bouquet Canyon Reservoir Dams. The Bouquet Canyon Reservoir Dams were the replacement structure for the St. Francis Dam which was completed in 1926 and failed catastrophically in 1928 killing at least 400 people. Proctor was asked to devise a method of testing compacted fill to help the LADPW demonstrate that they were constructing dams safely.

The test method was developed to determine the optimum moisture content for compacting soil for dam construction, in order to produce a stable structure. In his experimentation he discovered that for any given soil, a maximum dry density could be achieved at a specific water content, with a specific energy and compacted sample volume. His work was found to be especially useful for highway construction.

The test became known as the moisture-density test and the general concept as the moisture-density relationship of soils. The test is still often referred to today as the moisture-density test. The test and moisture-density relationship are only valid for soil materials including cohesive and cohesionless fine-grained soils and silty or clayey sands. The PennDOT version of the test is PTM No. 106 – The Moisture-Density Relations of Soils. PTM No. 106 was adapted from AASHTO Test Method No. T 99 using the same standard mold and rammer. The difference between the two methods is that PTM No. 106 does substitution for oversize particles (particles greater than 1/2 - inch), while AASHTO T 99 uses a mathematical correction for oversize particles (particles greater than 3/4 - inch).

The moisture-density test provides a target maximum dry density and optimum moisture content for compaction. During the test, a soil sample is compacted with a known standard compactive effort or energy into a mold of known standard volume. Moisture is varied for each test increment. For each moisture tested, a dry density of the compacted sample is determined. The density achieved is a function of three variables: the soil sample, compactive energy (specific energy or energy per unit volume), and the moisture content during compaction.

There are standard and modified versions of the test. The modified version is run at a significantly higher specific energy. The equipment used for the tests is shown in Figure 4.1-1 and include a rammer (sometimes referred to as a hammer), a mold, a sample extruder and a scale. Not shown in the figure is a straight edge steel blade used to level the sample with the top of the mold after compaction, and an oven is also required to dry a sample of the soil after it is compacted and extruded to determine the moisture content. The mold is of a standard known

volume and mass. The sample is weighed in the mold after compaction to determine the wet density of the compacted sample.

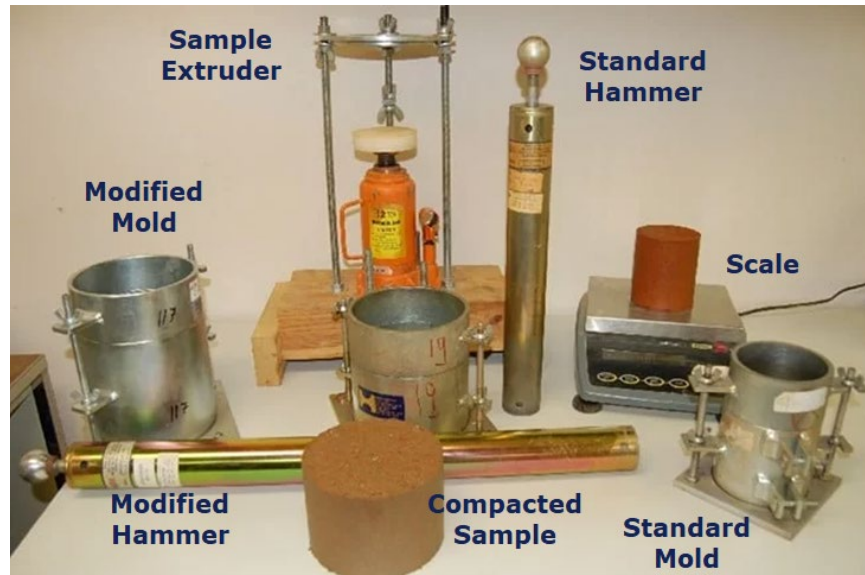

Figure 4.1-1 – Equipment to Perform a Moisture-Density Test

Source: <https://theconstructor.org/geotechnical/soil-maximum-dry-density-optimum-moisture-content/18426/> (Annotated)

As indicated above, PTM No. 106 is a modification of AASHTO T 99 with the major difference between the two procedures being the handling of coarse or “oversize” particles. The reason for adjusting or correcting for coarse material is the limitation in the mold size (4 - inch diameter) for the standard test. Two problems can result with samples having excessively large particle sizes. Both result from the small mold size and rigidity of the mold.

During compaction of the sample in the mold, large particles can get forced against the sides of the mold walls. During the lab test the lateral boundary conditions are soil against steel versus soil against soil in full scale field operations, with the steel walls of the mold having a much higher modulus and offering much greater lateral resistance. This results in increased resistance to the compactive effort that is not present in full-scale field operations.

For fine-grained soils, the increased lateral resistance actually results in a slightly higher density than in equivalent field conditions. More of the energy goes directly into the compacted sample because of the much stiffer boundary conditions (i.e., less stiff surrounding soil would attenuate or absorb some of the energy in an equivalent field condition). However, as coarse particles are introduced in sufficient quantities, compactive energy starts to be transferred through the larger particles, with less impact to the surrounding finer material. As the percentage of larger particles increases, the amount of compactive energy bypassing the finer particles increases.

The magnitude of the impact of the coarse particles will depend upon the size of the larger particles, the fraction or percent of oversize particles contained in the sample, and the material gradation. For example, the impact may be small for very well graded materials with a low percent of large particles, but increases as maximum particles size increases, the percent of larger particles increases, and the steeper the gradation curve.

The second issue with large particles is voids. As the percent of large particles increases, and those particles start to take more of the compactive energy, voids around the large particles can develop. The combination of possible voids and reduced energy to the finer soil particles can result in lower densities than would be achieved in full scale field operations. The target maximum dry density may be too low.

Further complicating the situation is the magnitude of compactive energy delivered by modern compaction equipment. Recall that the moisture-density compaction control was developed in the early 1930's. Larger compaction equipment at this time typically consisted of smooth drum rollers having a gross weight of around 10 tons, with contact pressures in the area of 50 psi (smooth drum rollers have relatively low ground contact pressures).

Modern compaction equipment is significantly larger, with typical gross weights of around 20 tons or more. Ground contact pressures of a padfoot roller of this mass would be in the range of 320 psi. The result is much higher compactive efforts applied in field operations with modern equipment, but with target moisture and density determined with 1930's era compactive efforts. This represents a significant disconnect between current laboratory and field procedures. Compaction energies of laboratory determined target moistures and densities for field operations are not representative of the compactive efforts applied in for modern construction practices and equipment.

With current laboratory practices already providing (at best) marginal target moisture-density values for modern compaction equipment, it is necessary to provide a means of correction for materials containing larger particles that would further lower target maximum dry densities. The AASHTO method (T 99) uses a mathematical procedure to correct for oversize particles (particles greater than 3/4 - inch). The PennDOT test method, PTM No. 106, replaces material retained on the 1/2 - inch sieve with an equal mass of minus 1/2 - inch to plus No. 4 material (i.e., material passing the 1/2 - inch sieve but retained on the No. 4 sieve).

The logic supporting the PTM No. 106 approach is that with such a relatively low specific surface area (i.e., surface area per unit volume), coarse particles have an inconsequential impact on optimum moisture content when a material contains a sufficient fraction of finer material. From a relative standpoint, the specific surface area of coarse particles is insignificant when compared to soil fines (i.e., material passing the No. 200 sieve).

With coarse particle substitution, the limited mass of an increased number of slightly smaller particles having a marginally higher specific surface, has essentially no impact on the optimum moisture content, maximum dry density, or performance of the compacted sample. The substituted material represents the extreme high end of the sample particle size, comprises by mass a small fraction of the sample, and by number of particles, an insignificant fraction of the sample. The substituted particles will be distributed through the mass of the compacted sample

much like the larger coarser particles they replaced, but without the negative impacts due to the voids resulting from rigid boundary conditions while compacting the sample.

While there is a difference in how the AASHTO test method and PennDOT PTM address “oversize” particles, the general test procedures are the same. General specifications for the standard test method are as follows:

- Mold Size: 4 inch diameter; 1/30 cu ft; with 2 inch high collar
- Hammer Requirements: 2 inch diameter flat face, 5.5 lbs, 12 inch hammer drop
- Sample Compaction: 3 equal lifts, 25 blows of hammer each lift
- Energy: Total = 412 lb-ft; Specific = 12,375 lb-ft/ft<sup>3</sup>

Except for oversize particle substitution, PTM No. 106 follows the standard moisture-density test procedure (AASHTO T 99). A brief general description of the standard test procedures is as follows:

- The mold for the standard test is a 4-inch inside diameter by 4.58-inch high bottom cylinder with a 2-inch high detachable collar. The bottom cylinder is attached to a removable base plate. The volume of the bottom cylinder is 1/30 cubic foot. The mass of the bottom cylinder and base plate are measured on a scale and recorded.
- The standard hammer weighs 5.5 lbs. and has a free drop of 12 inches
- Sufficient water is added and mixed into to the sample to bring the material to the approximate desired moisture content.
- The prepared sample is placed in the mold in three separate lifts of approximately equal proportions.
- Each lift is compacted with 25 blows of the hammer distributed uniformly across the top of the lift.
- Once the final lift has been compacted, the 2-inch collar is removed, and the sample is carefully trimmed level with the top of the bottom cylinder.
- The mass of the bottom cylinder with base plate and moist sample are measured and recorded.
- The base plate is then removed from the bottom cylinder and the compacted material is immediately extruded from the cylinder to obtain a sample for determining the moisture content.
- Once extruded, the compacted material is split down the middle and an adequate representative sample removed to determine the actual moisture content during compaction. The moisture content sample is immediately weighed and then placed in an oven to dry.
- Once the sample has been dried, it is again weighed and the moisture content during compaction is calculated.
- With the moisture content determined, the mass of the moist sample of known volume having been determined, the corresponding dry density is then calculated.

The above process is then repeated a sufficient number of times over a range of moisture contents to plot a moisture-density (M-D) curve. A minimum of five moisture-density x-y points should be obtained with a minimum of two points on either side of the curve peak. The moisture

values should be uniformly distributed along the x-axis to assure a well defined curve and well defined curve apex or peak (see Figure 4.1-2).

As described above, during testing, the soil sample and specific energy (i.e., rammer weight and drop), mold dimensions and volume, are held constant. The moisture content during compaction is varied for each test increment. A dry density is determined for each moisture content at which the sample is compacted. The individual moisture and dry density point sets are plotted to form the moisture-density curve (Figure 4.1-2). Moisture is plotted against the x-axis and dry density is plotted against the y-axis. A vertical line is drawn down to the x-axis from the apex or peak of the curve to obtain the optimum moisture content for the soil. A horizontal line is drawn across to the y-axis to obtain the maximum dry density.

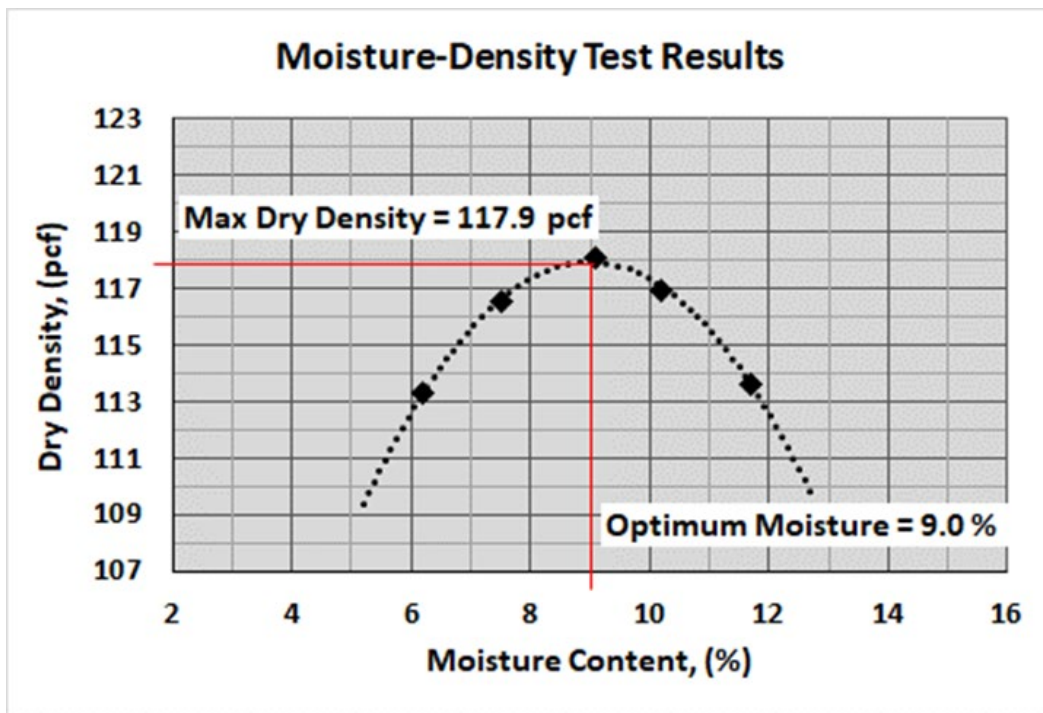

Figure 4.1-2 – Typical Moisture-Density Curve

#### 4.2 Interpretation of Moisture-Density (M-D) Testing

It is important to understand that moisture-density testing is simply a tool to aid in obtaining and verifying good compaction. The primary purpose of the test is to determine the optimum moisture content and maximum dry density of the material. These values are used to establish target field values according to agency specifications for moisture-density control during placement and compaction operations. During placement and compaction, the material must be within the allowable moisture band relative to the optimum moisture value, and is to be compacted to the specified percent of the established maximum dry density.

The test values are only valid if the samples tested are representative of the material being placed. The test samples are representative of the material being placed and compacted if the following conditions exist:

- 1) The test samples came from the same excavation or borrow source as the material being placed;
- 2) The test samples are visually and texturally consistent with the material being placed (i.e., same in appearance – including color and gradation, texture and consistency);
- 3) The test samples are visually of the same AASHTO soil classification as the material is being placed.

Any deviation from the above requirements, or any changes from the original moisture-density test sample in physical, behavioral, or performance characteristics of the material being placed require that new representative samples be obtained and new moisture-density tests be performed. It should be a standard practice that a portion of any moisture-density test sample be retained for reference on the project for comparative purposes, so that the above evaluations can be made with adequate accuracy and credibility.

If material is being placed from multiple sources, sufficient samples from each source should be obtained and tested to establish representative moisture-density target values for each source of material. Material can only be placed and compacted from one source at a time, and moisture-density requirements must be based upon the samples tested representing the material being placed. Combining samples from multiple sources to develop a “representative composite sample” must never be done. The “representative composite sample” will not represent any of the materials to be placed.

As observed from Figure 4.1-2, the typical shape of moisture-density curve is geometrically consistent with that of a parabola (i.e.,resembling the shape of a horseshoe). As can be observed from Figure 4.1-2, approaching (or on the dry side of) maximum dry density, dry density increases as moisture content increases. Past (or on the wet side of) maximum dry density, dry density decreases as moisture increases.

Approaching (on the dry side of) maximum dry density, as moisture content increases, soil particles are lubricated by the moisture. Lubrication increases with moisture, permitting the applied compaction load to **expel air voids** and arrange soil particles into a denser arrangement. Maximum dry density increases approaching the optimum moisture content. As shown in Figure 4.2-1, as the optimum moisture content is approached, the sample is nearing saturation. Based upon the various sources shown, the materials are somewhere in the area of 90 to 95 percent saturation at optimum moisture.

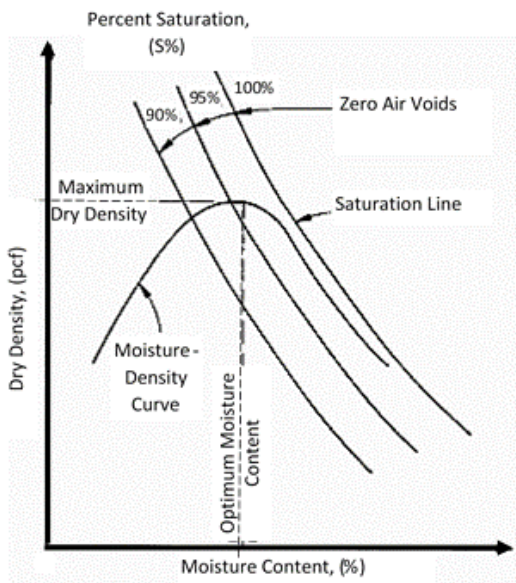

(a)

Source: <http://flatgeo.com/index.php/en/geotech-issue/soil-testing-issue/79-compaction-test> (Annotated)

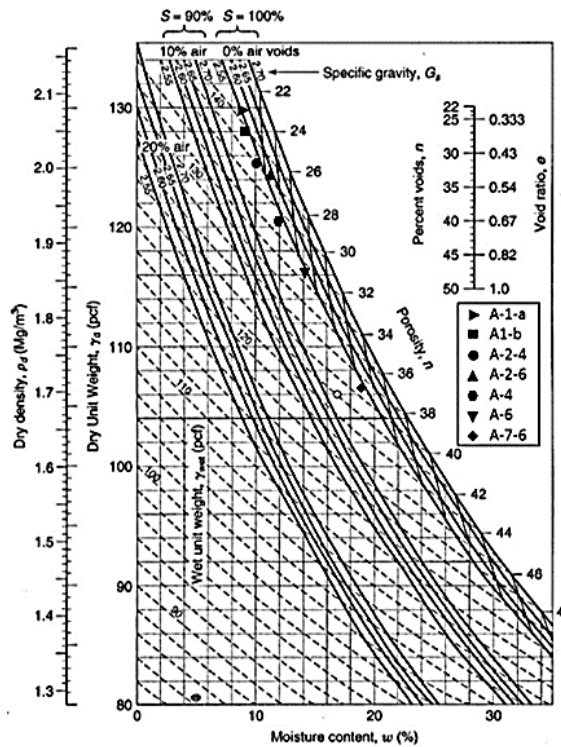

(c) Source: Unknown

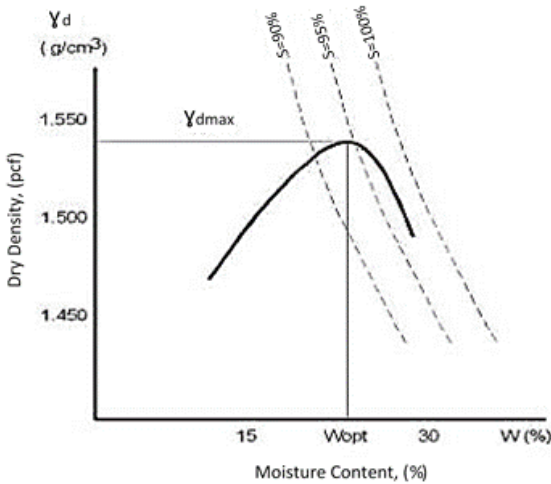

(b)

Source: <http://www.ejge.com/2004/Ppr0472/Ppr0472.htm> (Annotated)

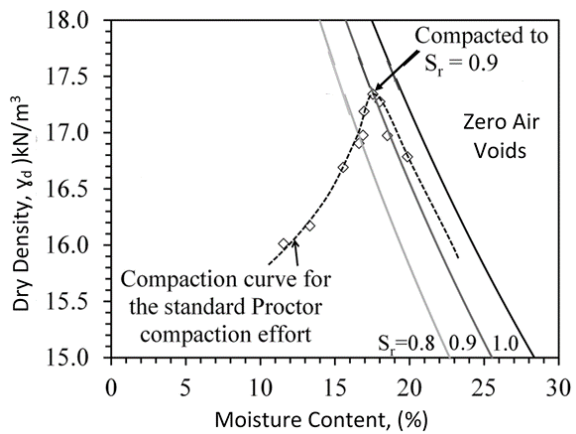

(d)

Source: [https://www.researchgate.net/figure/a-Standard-Proctor-compaction-curve-for-Boulder-clay-and-initial-compaction-conditions\\_fig3\\_279217002](https://www.researchgate.net/figure/a-Standard-Proctor-compaction-curve-for-Boulder-clay-and-initial-compaction-conditions_fig3_279217002) (Annotated)

Figure 4.2-1 – Percent Saturation at Optimum Moisture Content

As moisture continues to increase past the maximum dry density (see Figure 4.2-), the sample becomes completely saturated, and water starts to displace soil solid particles. Since the specific gravity of water is lower than that of soil solids ( $SG_{\text{solids}} \approx 2.6$  while  $SG_{\text{water}} = 1.0$ ), water has a lower density than the soil solid particles. So as moisture increases past the optimum moisture content and water starts displacing soil solids, the density of the saturated soil mass decreases.

As was described earlier, the moisture-density relationship of soil is dependent upon three variables: the soil characteristics (gradation and mineral types), water and compactive energy. Thus, for a given soil, the moisture-density relationship will change as the compactive effort or compactive energy changes. In general, the relationship is as the compactive energy increases, the maximum dry density increases and the optimum moisture content decreases (see Figure 4.2-2).

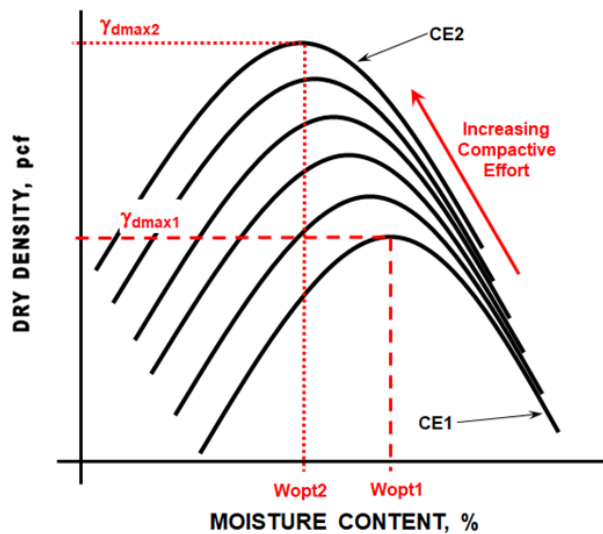

Figure 4.2-2 – Effect of Compactive Effort on Moisture-Density Relationship of Soil

While the general shape of a soil moisture-density curve is parabolic, the specific shape of the curve, how broad or steep the parabola, varies with the soil material. And just like a soil gradation curve, the shape of a materials moisture-density curve can provide a lot of information about the soil. Also like a gradation curve, it is the shape steepness and location of the moisture-density curve that is useful for estimation of soil type, properties and behavior. The key to being able to make a useful and credible interpretation of a moisture-density curve is plotting scale.

Consider the moisture-density curves for soils A, B and C below (see Figure 4.2-3). The three soils consist of materials from across the spectrum of classifications, having significantly different characteristics, properties and behavior. Closer inspection of the three curves indicates the three materials each have very different optimum moisture content and maximum dry densities. Yet the curves look nearly identical, with nearly identical positions. The parabola's



drawn over the three curves in Figure 4.2-3(b) are identical, and yet they fit each individual curve nearly perfectly.

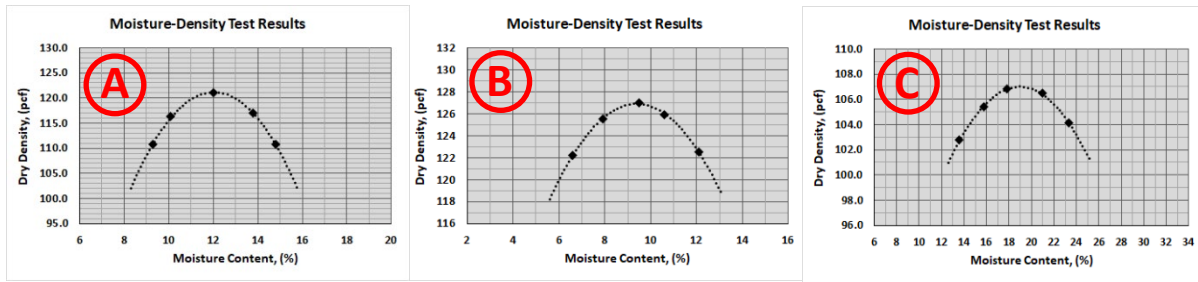

(a)

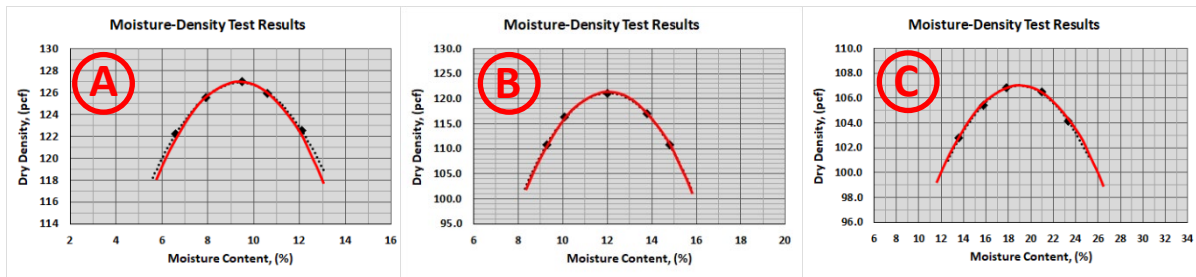

(b)

Figure 4.2-3 – Moisture-Density Curves for Three Different Soils

The key to obtaining useful information concerning anticipated soil properties and behavior, lies in the plotting scale. Another close inspection of the three curves indicates the plotting scales of each curve are very different. For the x-axis (moisture content), the plotting scales range from a low of 14 percent moisture span for materials A and B, to a high of 28 percent moisture span for the material C curve. For the y-axis (maximum dry density), the plotting scales range from a low of 14 pcf density span for material C, to a high of a 35 pcf density span for the material A curve.

Now consider the moisture-density curves for soils A, B and C in Figure 4.2-4. These curves are for the exact same soils as in Figure 4.2-3, but appear very different. The shape, steepness and location of the three curves varies significantly from those depicted in Figure 4.2-3. By plotting all three curves on identical scales, the differences in the curve shapes and relative locations (moisture and density), becomes readily apparent.

Much like gradation curves (discussed in Section 3.3.1), a materials density (M-D) curve shape and location (i.e., the magnitude of optimum moisture and maximum dry density) can be very useful in assessing soil type, behavior and performance. Considering the curve for material “A”, we see that the curve yields the highest maximum dry density (MDD), 127 pcf, and lowest optimum moisture content (OMC), 9.5%, of the three materials. The shape of the curve is neither very broad nor steep. The shape and moisture-density values indicate that this material is

likely a sand (classification is likely either on the fine side of an A-1-b or the coarse side of an A-2-4).

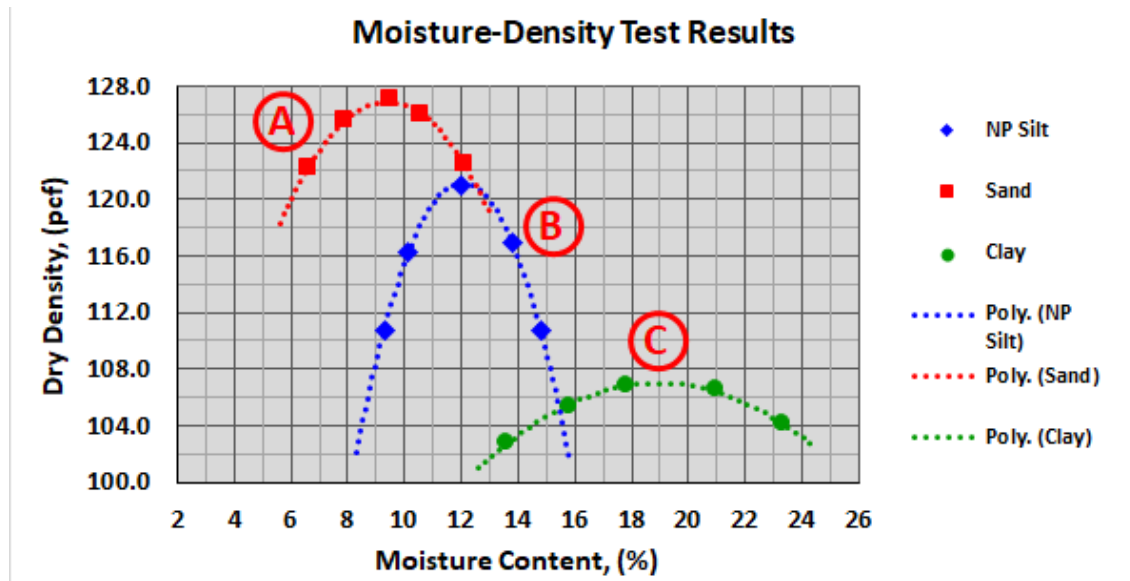

Figure 4.2-4 – Moisture-Density Curves for Three Soils Plotted on the Same Scale

By contrast, we see that the curve for material “C” yields the lowest MDD (107 pcf) and highest OMC (19%). The shape of the curve is very broad, with a roughly one pound per cubic foot change in dry density of a six percent range of moisture content (+/-3% of OMC). This material indicates little sensitivity to changes in moisture. The broad curve, low sensitivity to variations in moisture, low MMD and high OMC, indicate this material to be a high plasticity clay (likely an A-7-6 classification).

Now looking at the curve for material “B”, we find a MDD of 121 pcf and an OMC of 12 percent – values in between materials “A” and “C” (the sand and clay). The curve is very steep with drops in MDD of 5 pcf with a plus or minus 2 percent change in moisture. Unlike the clay, the rapid drop in MMD on either side of OMC indicates this material to be highly sensitive to changes in moisture. The steep curve shape, moisture sensitivity, and values for MDD and OMC, indicate this material is likely a non-plastic silt.

For values of MMD and OMC, the general trend is that coarse-grained, low plastic materials result in higher MDD’s with lower OMC’s (e.g., sands and silty sands), while fine-grained plastic soils yield lower MDD values and higher values for OMC (e.g., clays and silty clays). Silts, sandy silts and clayey silts range in between, with the MDD and OMC values dependent upon the fines content and plasticity of the fines. Less fines and lower plastic fines will generally lean more towards sands, and higher fines content and/or higher plasticity fines will have MDD’s and OMC’s leaning more towards clays.

Table 4.2-1 provides typical (average) values of MMD and OMC for various AASHTO soil classifications. **These are only typical values.** Actual material MDD and OMC values can

range significantly depending upon the fines content and plasticity of the fines. The values are averages based upon a compilation of CAMMS test data.

Table 4.2-1 – Typical Values of Maximum Dry Density and Optimum Moisture Content for Various AASHTO Soil Classifications		
AASHTO Classification	Optimum Moisture Content, (%)	Maximum Dry Density, (pcf)
A-1-a	8.7	130.1
A-1-b	8.9	128.4
A-2-4	10.1	125.6
A-2-6	10.7	125.1
A-2-7	15.0	115.0
A-4	11.9	120.8
A-6	14.2	116.5
A-7-6	18.9	106.6

As indicated in the discussion above, the key to making M-D curves useful beyond simply providing the materials MDD and OMC, is plotting scale. Consistent plotting scale permits observing the relative shape of the M-D curve for a given material, and the values of OMC and MDD relative to the values for other materials. Put simply, contrast is important and necessary. A consistent plotting scale provides context to evaluate a given material’s M-D curve and values of MDD and OMC, so that material type, behavior and likely performance, can be interpreted from the plotted data. It is recommended to always plot M-D test data on a 2:1 vertical to horizontal scale (2 pcf density:1 percent moisture). In other words, geometrically the length of one percent moisture on the horizontal scale should be equivalent to the length of 2 pcf density on the vertical scale (see Figure 4.2-4).

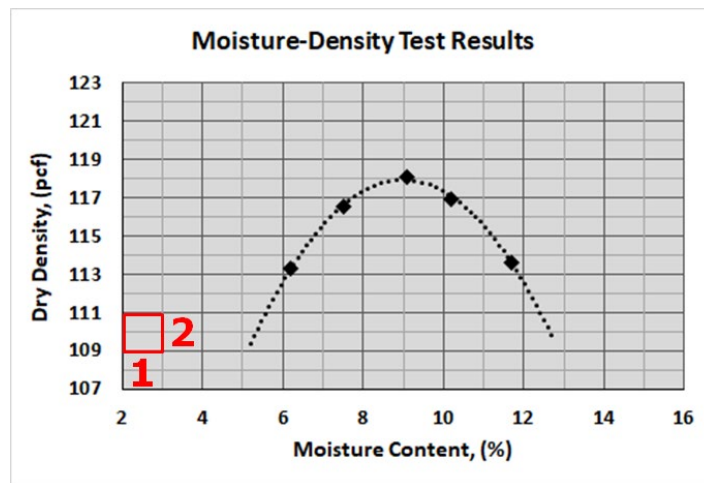

Figure 4.2-4 – Recommended Plotting Scale to Effectively Interpret Moisture Density Test Data

## **Chapter 5 – Compaction Equipment**

### **5.1 Introduction**

There is a broad range of types and sizes of compaction equipment available. Large operator driven rollers are used for full scale operations and smaller hand operated equipment is used for confined spaces such as trenches and areas where it is necessary to limit induced lateral stresses. Equipment comes in vibratory models, static models, and some models can operate in both vibratory and static mode. Different types of equipment function via different mechanisms and compaction surfaces. Variables in selection of equipment include the compaction surface size and geometry, compactor mass, and whether the equipment operates statically or dynamically (i.e., vibratory equipment). All these variables determine the equipment energy and contact pressure and how the energy from the compactor is transferred to the material being compacted.

The key to choosing compaction equipment is understanding the properties of the material to be compacted. The nature of the material being compacted dictates the compaction equipment required. The mechanism used by the equipment must be effective in achieving volume change for the particular material. Not all modes of compaction are compatible for every type of material. This section will describe the common types of equipment available for use. However, the mechanics of how vibratory rollers and padfoot rollers function in achieving compaction will be covered in Section 6 – Mechanics of Compaction.

### **5.2 Smooth Drum Vibratory Roller**

A smooth drum vibratory roller consists of a single smooth drum in the front and a propeller with large pneumatic tires in the rear (see Figure 5.2-1). There is a mechanism known as an exciter inside the drum that causes the drum to vibrate. How this mechanism functions will be discussed in Section 6 of this manual. Typically, this type of equipment can be operated in either static or vibratory modes. However, in static mode this type of equipment is not highly efficient since the contact pressure under a smooth drum roller in static mode is generally low (high end of 55 psi for a 15 ton roller drum).

The efficiency of a smooth drum roller operated in vibratory mode depends upon a variety of factors including:

- Drum Static Weight
- Drum Width
- Vibration Frequency (frequency of exciter rotation)
- Vibration Amplitude
- Exciter Configuration (mass of the rotating weight and distance of center of gravity of the weight from axis of rotation or eccentricity)
- Roller Travel Speed



Source: <https://www.equipmentworld.com/bomags-new-single-drum-vibratory-roller-line-handles-range-of-soil-surfaces/>

Figure 5.2-1 – Smooth Single Drum Roller

Operator driven rollers typically have a drum width of 84 inches. The drum static weight of smooth drum rollers generally ranges from 8 to 20 tons, with a 15 ton drum weight being common. The exciter configuration (i.e., mass and eccentricity) and rotation frequency determine the magnitude of the centrifugal (i.e., dynamic) force developed by the exciter. The total compaction force is the sum of the static and dynamic forces. However, the dynamic component is more productive because of the momentum transferred to the mass being compacted.

By far the two most important of the above factors impacting roller efficiency are the frequency and roller speed. The centrifugal or dynamic force developed by the exciter is a function of the square of the frequency, so frequency has a proportionally greater impact on the magnitude of the centrifugal force than the mass of the exciter and the eccentricity. Roller travel speed controls the time the material being compacted has to respond to the dynamic energy. Combined with slow roller speed, dynamic energy provides smooth drum rollers with the capability to efficiently and effectively compact granular soils and aggregates.

### 5.3 Padfoot Roller

A padfoot roller is essentially identical to a smooth drum roller except for the drum configuration. Instead of a smooth drum surface, a padfoot roller has pads or feet protruding from the drum surface aligned in a repeating pattern distributed uniformly on the surface of the drum (see Figure 5.3-1). Frequently a padfoot roller is just a smooth drum roller with a bolt-on padfoot drum liner attached (see Figure 5.3-2).

The contact area of the pads is typically around 20 square inches, and the pads occupy approximately twenty percent of the drum surface. While static contact pressure of a smooth drum roller is typically low, contact pressure under the pads of a padfoot roller are quite high, ranging from 250 to 550 psi. While the static weight of the roller drum is not as critical for a smooth drum roller operated in vibratory mode, high static drum weight is very important for a padfoot roller operated in static mode, since for a given padfoot drum geometry, the static drum weight will determine the contact pressure of the pads. Combined with slow roller speed, high

contact pressures provide padfoot rollers the capability to efficiently and effectively compact fine-grained soils and materials with  $\geq 20$  percent fines (passing the No. 200 sieve).



Source: <https://www.plantminer.com.au/hire/caterpillar-20-tonne-single-drum-padfoot-roller-205716>



Source: <https://www.forconstructionpros.com/equipment/compaction/single-drum-rollers/product/10085844/bomag-americas-inc-bw21340-series-rollers>

Figure 5.3-1 – Typical Padfoot Rollers



Source: [https://www.alibaba.com/product-detail/padfoot-segment-for-single-drum-roller\\_115053427.html](https://www.alibaba.com/product-detail/padfoot-segment-for-single-drum-roller_115053427.html)

Figure 5.3-2 – Bolt-on Padfoot Drum Liner

## 5.4 Hand Operated Equipment

Hand operated equipment is primarily used for confined spaces or small areas where it is simply not practical to use large operator driven compactors or adjacent to structure components where there is a need to limit induced lateral loads from compaction. There are a variety of hand operated equipment types. They generally fall into one of the following three categories (see Figure 5.4-1).

- Hand Operated Rollers
- Vibrating Plate Compactors
- Tampers/Rammers

Figure 5.4-2 illustrates the energy actuator systems of the three types of equipment.



Source: <https://www.allcotthire.com.au/product/trench-roller/>

(a) Walk-behind Roller



Source: <https://www.tradebit.com/filedetail.php/276144382-jcb-vmd70-vmd100-double-drum-walk-behind>

(b) Trench Roller



Source: [https://www.alibaba.com/product-detail/Top-sell-C-60-used-wacker\\_985360039.html](https://www.alibaba.com/product-detail/Top-sell-C-60-used-wacker_985360039.html)

(c) Vibrating Plate Compactor



Source: <https://californiatoolsandequipment.com/products/6-5hp-tamping-tamper-rammer-jumping-jack-plate-compactor-walker-gas>

(d) Tamper

Figure 5.4-1 – Hand Operated Compaction Equipment

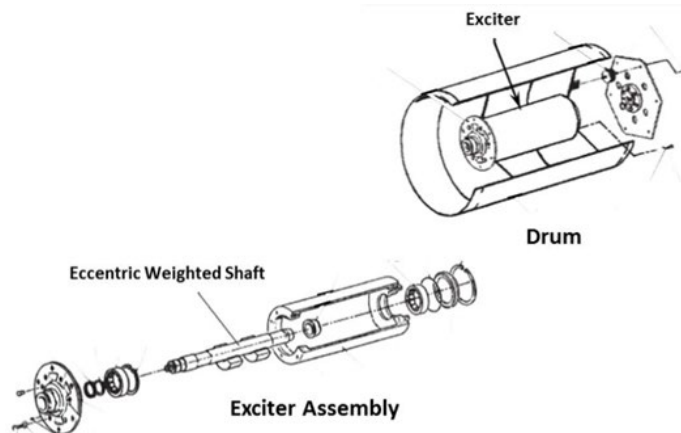

(b) Exciter Assembly for Typical Walk-behind Roller

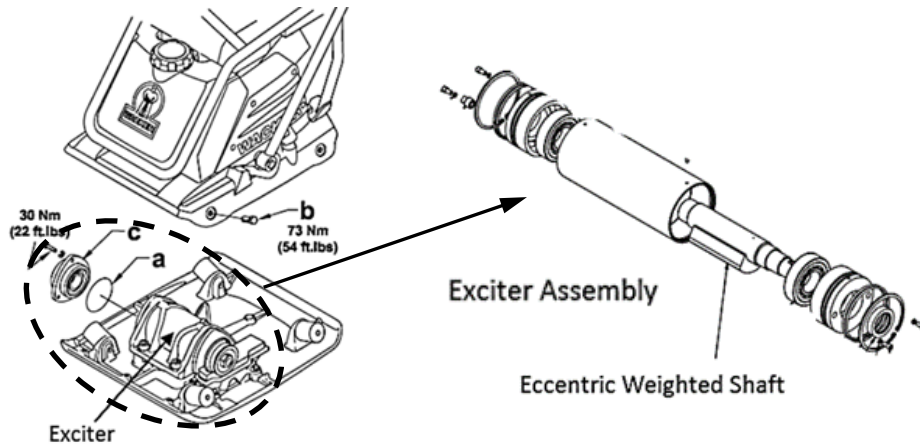

(c) Exciter Assembly for Typical Vibrating Plate Compactor

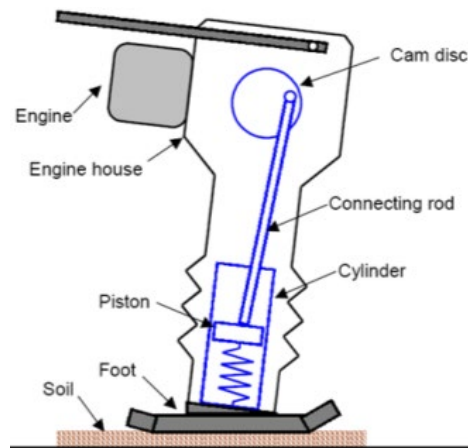

(d) Piston Drive Assemble for Typical Tamper/Rammer

Figure 5.4-2 – Energy Actuator Systems for Hand Operated Compaction Equipment

A walk-behind roller and a trench roller are essentially the same type of equipment. Trench rollers can be a little bigger in size and mass, but the two machines operate on the basis using exciters inside the drum rollers to create vibrations. Trench rollers are also sometimes articulated for maneuverability, and usually have small protrusions on the roller drums similar to the feet of a padfoot roller. However, the feet on a trench roller do not protrude out from the roller very far and function only for traction on sloping surfaces – they do not function like the feet on a padfoot roller.

All of the hand operated equipment is dynamic, with the rollers and plate compactor being vibratory equipment. The difference between the vibratory equipment and the tamper can be found in how the dynamic energy is applied. Vibratory plate compactors and walk-behind rollers have very low amplitudes (i.e., the distance the plate or roller moves up and down with each vibration cycle), but a high frequency (i.e., the number of cycles per second). Conversely, the tamper has a high amplitude (i.e., vertical travel of the tamper plate with each cycle), but a



relatively low frequency. While the energy from a tamper is dynamic, the frequency is not sufficient to induce vibrations.

This would seem to imply to some that one type of equipment is more efficient than the other. However, the two types of equipment use different types of energy (e.g., low amplitude high frequency dynamic versus high amplitude low frequency dynamic), have different operating masses with different suspension systems (suspension systems isolate the exciter from the rest of the frame to protect equipment components), and different plate/roller geometries, so it is very difficult to directly compare the two types of equipment.

It comes down to selecting the equipment appropriate for the material, operating time over the material, and controlling lift thickness so that sufficient energy is delivered to the full thickness and area of the material being compacted. Vibratory equipment is often better suited for aggregates and more granular soils, while tampers are often more suitable for fine-grained soils (along with proper moisture control). A tamper operates and delivers energy very similar in manner to the hammer for a moisture-density (proctor) test. A general statement concerning hand operated equipment is that it does not have adequate mass and energy to adequately compact thicker lifts of either granular or fine-grained materials. Lifts must be kept to a maximum 4-inch compacted thickness when using hand operated equipment.

## **Chapter 6 – Mechanics of Compaction**

### **6.1 Introduction**

Regardless of how a material is compacted, efficient densification is dependent upon shearing between material particles when the compaction energy is applied. The application of compressive loads alone will not produce effective and efficient compaction. There must be shearing between individual particles to achieve volume change. The shearing must be local between individual grains as opposed to development of a shear failure surface (see Figures 6.1-1 and 6.1-2).

As can be observed in Figures 6.1-1 and 6.1-2, with generalized shear failure twin shear failure surfaces form under the loaded area with the soil bulging upward on either side resulting in no volume change. Without volume change, no compaction has been achieved (i.e., no reduction in air voids). With punching shear, the load penetrates into the soil with localized shearing and deformation limited to beneath the loaded area. The result is volume change, a reduction in air voids, and therefore, densification (compaction) of the soil. So in effect, the applied compactive force must be able to overcome the shear strength of a material for compaction to occur.

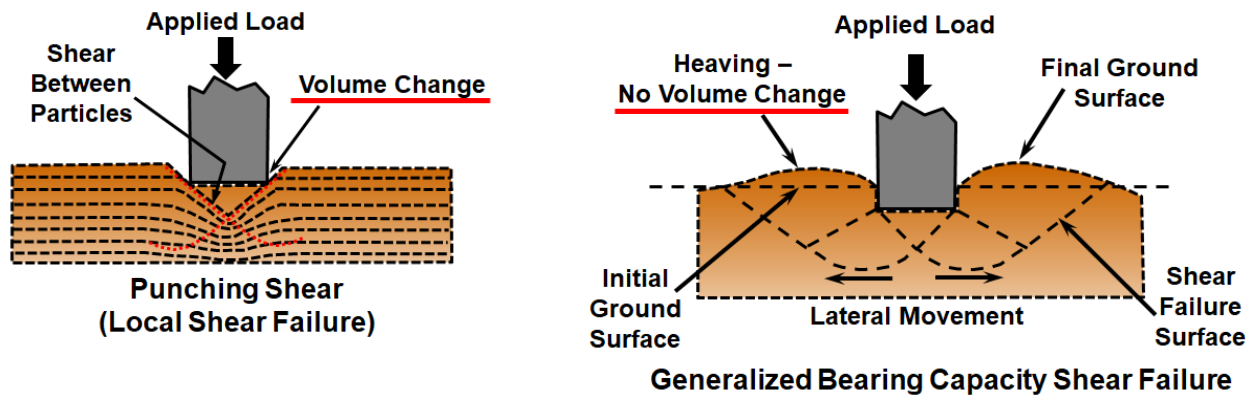

To achieve volume change must shear soil locally beneath the applied load to effect volume change (reduction in voids)

Figure 6.1-1 – General versus Local Shear (Volume Change)



Soil Rutting – Generalize Bearing Capacity Failure (**No Volume Change**)



Lab Test – Punching Shear (**Volume Change**)

Source: [https://youtu.be/MS4H\\_u0ARpo](https://youtu.be/MS4H_u0ARpo) 2019/10/31/how-minimize-soil-compaction-during-harvest/4117205002/

Figure 6.1-2 – General Bearing Capacity Failure versus Punching Shear

## 6.2 Static Compaction

As indicated in Chapter 3, the shear strength of soil can have two components: the cohesive component and the frictional component. While the cohesive component is independent of stress, the frictional component is stress dependent, meaning stress between soil or aggregate particles is required to mobilize the interparticle friction.

$$S = c + \sigma' \tan(\phi)$$

Where: S = shear strength, (psf)  
c = cohesion, (psf)  
 $\phi$  = soil friction angle, (degrees)  
 $\sigma'$  = effective overburden stress (the stress resulting from soil particles being pushed together), (psf)

and  $\sigma' = \sigma - \mu$

where:  $\sigma$  = total overburden stress  
 $\mu$  = pore water pressure

From the above equation, two factors concerning effective stress become evident. First, as stress between the particles increases (i.e., the effective stress), the shear strength increases. The increase in stress between particles is a consequence of compaction resulting in the reduction of voids and volume change in the material. The volume change results in the particles being pushed tighter together. Second, as pore water pressure increases, the effective stress decreases, and therefore, the shear strength decreases.

Source: <https://www.wisfarmer.com/story/news/2019/10/31/how-minimize-soil-compaction-during-harvest/4117205002/>

Recall from Chapter 4 that when compacting soil, as the material gets near maximum dry density at optimum moisture content, the material is approaching saturation. In this range, that application of too much energy can result in the buildup of excess pore pressures since water is incompressible – the water in effect pushes back. This is the case for fine-grained soils or soil with sufficient fines content (i.e., material with approximately  $\geq 20\%$  passing the No. 200 sieve).

Any material having a sufficiently low permeability such that water cannot readily escape while subject to a compaction load is subject to the development of excess pore pressures during compaction. When this occurs, instead of simply overcoming the materials shear strength to achieve volume change (i.e., void reduction), the process is actually reducing the materials shear strength. At this point, fine-grained soils actually start to become unstable when compacting. A shear wave can develop in front of and behind the roller (see Figure 6.2-1). This is often referred to as heaving and pumping. This is especially prevalent when attempting to compact fine-grained soils, or soils with  $\geq 20$  percent fines, with a smooth drum roller operated in vibratory mode.

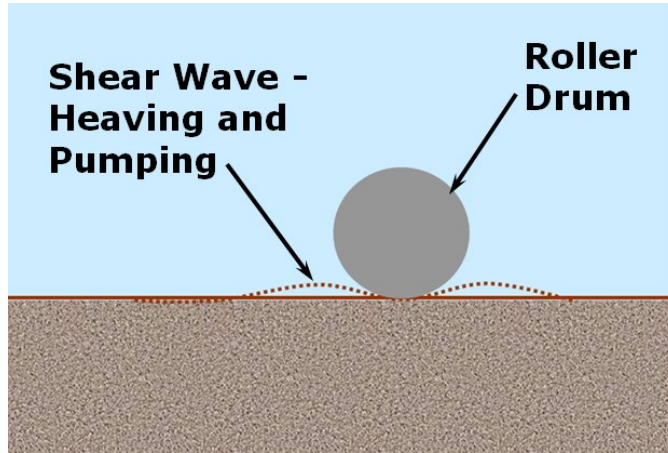

Figure 6.2-1 – Shear Wave – Heaving and Pumping

While a high degree of saturation is required for excess pore pressures to develop, how much pore pressure can develop and the rate at which the pore pressures can dissipate, are functions of the permeability of the soil and the length of the drainage path (see Figure 6.2-2 and 6.2-3). The solution to this problem is to use static compaction with discretely applied loads. As was discussed in Section 5, this requires compacting fine-grained soils and soil containing  $\geq 20$  percent fines (i.e., material passing the No. 200 sieve) using a padfoot roller in static mode.

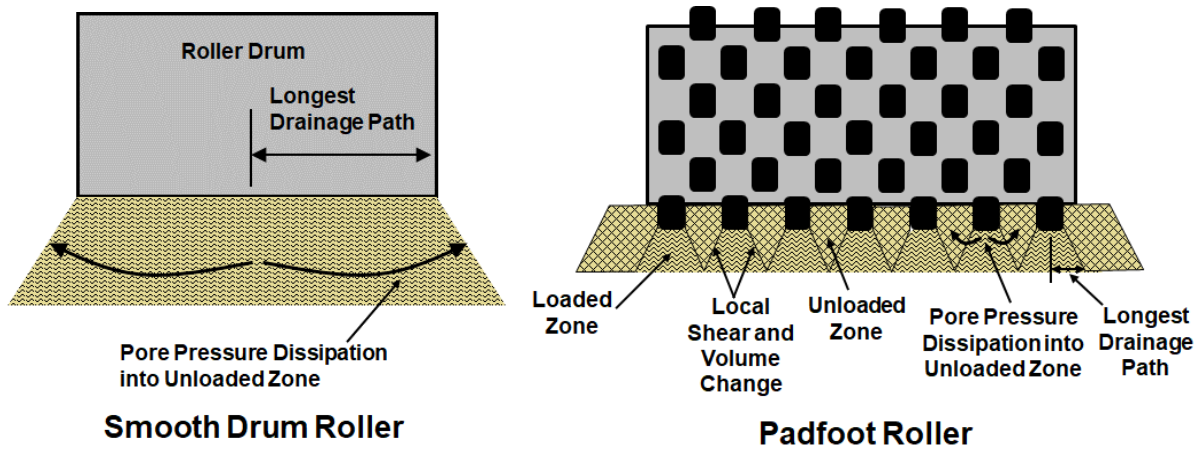

Figure 6.2-2 – Pore Pressure Dissipation – Smooth Drum vs. Padfoot Roller

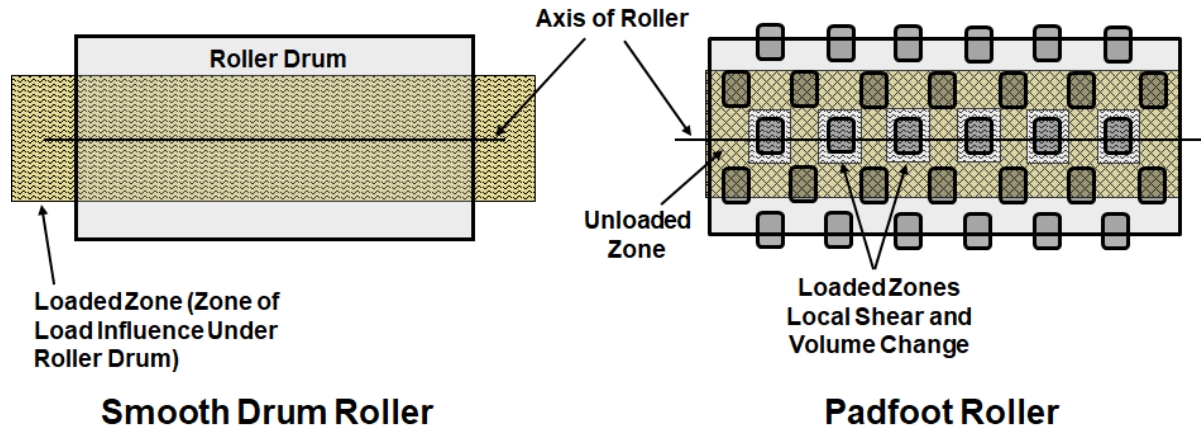

Figure 6.2-3 – Loaded vs. Unloaded Areas – Plan View of Smooth Drum vs. Padfoot Roller

As can be observed in Figure 6.2-2, the drainage path along the axis of the roller is much longer for a smooth drum roller than a padfoot roller. More significantly, as observed from Figure 6.2-3, as a result of the discretely applied loads from the roller pads, the loaded area under a padfoot roller is a fraction of that for a smooth drum roller. The roller geometry resulting in discretely applied loads of relatively small area provide two significant benefits: high contact pressures and unloaded zones surrounding the discreet load areas where any excess pore pressures can dissipate.

The roller pads result in punching shear as shown in Figures 6.1-1 and 6.1-2. This results in localized shearing between soil particles, creating volume change (i.e., void reduction), and therefore, effective compaction of the soil. In addition, the penetration of the pad feet resulting in the lift placed being compacted more from the bottom up than from the top down. This results in more effective densification of the lower portions of very lift placed and compacted.

### 6.3 Dynamic (Vibratory) Compaction

As with static compaction, when using dynamic compaction, efficient and effective densification is still dependent upon shearing between material particles when the compaction energy is applied. However, there is a fundamental difference in the mechanics involved with dynamic compaction. As discussed in Section 5, dynamic compaction is required for granular materials.

When compacting fine-grained materials using static compaction, there is a need to prevent weakening of the material by generating excess pore pressure during compaction. Since granular materials have higher permeability and are relatively free draining, there is not the concern or risk in developing excess pore pressures during application of compaction loads. Contrary to static compaction, the desire when using dynamic compaction is to **temporarily** reduce the shear strength of the material.

This is achieved by application of a rapidly cycling dynamic force. The rapid cycling induces high frequency vibrations, typically 30 to 40 Hz or 30 to 40 cycles per second. The vibrations are created by a device known as an exciter. The exciter is simply a rotating eccentric weight inside the roller drum (see Figure 6.3-1). The weight rotates rapidly around the axis of

the drum axle creating a centrifugal force acting outward and perpendicular to the roller drum surface. While the orientation of the force is always outward from the center of the drum, since the weight is rotating around the axis of the drum axle at 30 to 40 rpm, the direction of the force is constantly changing.

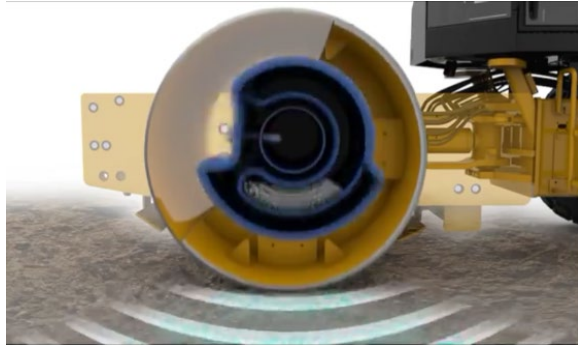

(a)

Source: [https://www.cat.com/en\\_US/products/new/equipment/compactors/vibratory-soil-compactors/18558722.html](https://www.cat.com/en_US/products/new/equipment/compactors/vibratory-soil-compactors/18558722.html)



(b)

Source: [https://www.bomag.com/mobile/variocontrol/pdf/PRE104006\\_0811.pdf](https://www.bomag.com/mobile/variocontrol/pdf/PRE104006_0811.pdf)

Figure 6.3-1 – Exciters in Vibratory Roller Compactors: (a) Cat® B-Series Vibratory Soil Compactor, (b) Bomag® Variocontrol I Smart Compactor

When the eccentric weight is oriented vertically upward the centrifugal force is directed upward working against the mass of the compactor, momentarily reducing the downward force of the drum. When the eccentric weight is oriented vertically downward the centrifugal force is directed downward working with the mass of the compactor, momentarily increasing the downward force of the drum. This induces a rapid vibration of the drum, and a rapid dynamic loading on the material being compacted.

The result is a phenomenon similar to liquefaction where the rapid vibrations cause a nearly complete loss of stress between the granular soil particles (i.e., essentially the  $\sigma'$  or effective stress in the shear strength equation). With the temporary loss of effective stress, interparticle friction cannot be mobilized, and there is a near total, but temporary, loss in shear strength. This condition will exist as long as the material is experiencing the rapid vibrations.

During the period of shear strength loss, the combined static and dynamic loads applied by the roller, force the material into a tighter arrangement resulting in volume change and void reduction. The material is densified by causing a temporary loss of shear strength. As soon as the vibratory roller moves on and the vibrations stop, the particles regain contact with one another, but at an increased interparticle contact stress. The effective stress increases since the particles have been forced tighter together. Not only has the material density increased, but as a result the material shear strength has increased.

#### 6.4 Roller Speed

Regardless of whether a material is to be compacted using static padfoot equipment or vibratory smooth drum equipment, proper roller speed is critical. Following the requirement of

PennDOT Publication 408, Section 206, roller speed cannot exceed 1.5 feet per second (1 mph). Slower roller speed results in greater operational efficiency. In other words, by slowing down the speed of the roller, it will take less total time to achieve the required level of compaction (see Figure 6.4-1). As can be observed from Figure 6.4-1, higher dry densities are obtained with fewer roller passes at slower speeds. Not only is there better operational efficiency, but slower roller speeds can achieve greater overall densities.

The reason slower roller speeds result in more effective and efficient compaction is that the material, fine-grained or granular soil, simply needs time to respond. This applies equally to static or vibratory compaction methods. The longer the load remains on the area being compacted, the proportionally greater the density achieved.

For static compaction, when the padfoot punches into the soil, slowing the speed of the roller down permits the compressed air voids extra time to escape from beneath and around the pad, rather than simply rebounding after the roller moves forward. For dynamic or vibratory compaction, slow roller speed permits the vibrations to penetrate fully. Once the vibrations have temporarily reduced the material shear strength, the slow speed allows for sufficient dynamic load cycles from the spinning eccentric weight in the drum to force the particles into a denser arrangement before the roller moves forward. Once the roller passes, the vibrations cease permitting the particles to lock back up.

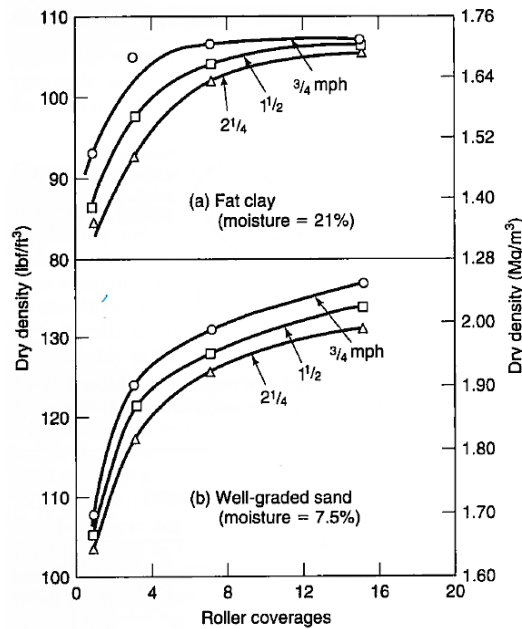

Source: Holtz, Kovacs and Sheehan, An Introduction to Geotechnical Engineering, 2<sup>nd</sup> Ed., 2011

Figure 6.4-1 – Dry Density vs. Roller Speed

## Chapter 7 – Field Operations

### 7.1 Introduction

This section brings together all the information presented in previous sections to compile the practices and operations necessary to manufacture earthen structures. It brings together the components and procedures required for proper placement and compaction of soil and aggregate. The components include:

- Material
- Equipment
- Personnel

The procedures include:

- Placement
- Compaction
- Quality Control, Acceptance and Verification

Discussion will first focus on the components listed above. Materials, which have been defined and discussed throughout the previous sections, include soil (fine-grained and granular), aggregates, rock and water. Equipment includes the compaction equipment discussed in Chapter 5, but also equipment necessary to excavate, transport, place and uniformly spread the materials in preparation for compaction. This document specifically addresses the equipment for compaction. Equipment for all other phases of operation are beyond the scope of the discussions in this manual. Finally, personnel includes all individuals involved and responsible for the material placement, compaction and acceptance.

Personnel involves a wide range of individuals including contractor, Department, and frequently, consultant personnel. For the contractor there are equipment operators, various workers, field office staff, individuals directing operations, and may include testing (QC/QA) personnel. Personnel involves anyone involved in the performance, documentation and direction of the flow, and completion of the procedures necessary to manufacture the earth structure. Consultant staff are very often involved in documentation and coordination of operations, and may be involved with QC/QA, verification and acceptance. Department personnel are involved in QC/QA, verification, acceptance, documentation and oversight.

All of these individuals work as a team to implement safe, proper, effective and efficient manufacturing (i.e., construction) of the earth structure, and assure the quality of the final product. When mutual support and cooperation fails, the quality of the structure suffers. The earth structure is virtually always supporting another project feature or adjacent structure.

The components of earth structure manufacturing (i.e., material, equipment, and personnel) have been discussed above and in previous section of this document. The remainder of the section will involve the procedures: placement, compaction, QA/QC and verification/acceptance.



## 7.2 Placement

There are three elements that must be addressed and controlled in the placement of earth materials in preparation for compaction. These include:

- Proper/Required Thickness
- Uniform Thickness
- Proper Grading

Fill materials must be placed in loose layers to achieve the desired compacted thickness. The allowable compacted thickness is a function of the material being placed and the compaction equipment that will be used. Full material lift thicknesses are used when compacting with operator drive compaction equipment – padfoot roller and smooth drum vibratory rollers. Thin lifts are placed when compacting with hand operated equipment.

Department specification requirements for compacted lift thickness are indicated in Table 7.2-1 below.

Table 7.2-1 – Department Requirements for Compacted Lift Thickness by Material Type and Compaction Equipment		
Material Type	Compaction Equipment Type	
	Operator Driven Rollers (Static Padfoot and Smooth Drum Vibratory Rollers)	Hand Operated Equipment
	Maximum Compacted Lift Thickness (inches)	
Soil	6	4
Granular, Type 1	6	4
Granular, Type 2	8	4
Random	6	N/A*
Shale	6	
Rock	36	

\* Random, Shale and Rock materials cannot be placed in confined areas

It is essential that placement of material must be completed to produce lift of uniform thickness. The importance of uniformly thick layers cannot be underestimated. Non-uniform layers will not compact to uniform density, stiffness and strength. The response to loads for such materials will not be uniform. The performance of structures to be supported by earthworks, especially pavement structures, is dependent upon a foundation with uniform strength and consistent response (i.e., uniform deflection) to loads.

During placement it is important to grade materials, especially soil, so that water can freely drain off compacted surfaces. Completed lifts should have a uniform surface without any low areas. Low areas will collect water during rain events and are evidence of non-uniform lift thickness. Lifts of soil material should be sealed with passes of a smooth drum roller operated in static mode at the end of every work shift and when an imminent rainstorm is approaching.

### 7.3 Compaction

As has been discussed in previous sections of this document, it is important to select the proper compaction equipment for the material being compacted. The equipment must be matched with the material. This include the size/energy, how the energy is delivered, and the roller geometry/surface. Table 7.3-1 indicates the Department requirements for compaction equipment according to the material being compacted.

Material Type	Full Scale Operations		Confined Spaces/Areas
	Equipment Type	Department Specification Section(s)	Department Specification Section(s)
Soil	Padfoot Roller Operated in Static Mode*	Sec 108.05(c)3.g	Sec 108.05(c)3.d (Trench and Walk-behind Rollers) Sec 108.05(c)4.a (Tampers/Rammers) Sec 108.05(c)4.b (Vibrating Plate Compactor)
Granular, Type 1	Smooth Drum Operator Driven Roller Operated in Vibratory Mode	Sec 108.05(c)3.h	
Granular, Type 2			
Random Shale Rock	Smooth Drum Operator Driven Roller Operated in Vibratory Mode	Sec 108.05(c)3.h	N/A**

\* Smooth drum operator driven rollers operated in static mode may be used on soil for an initial breakdown pass and must be used to seal soil surface at the end of shifts and if an imminent storm is approaching

\*\* Random, Shale and Rock materials cannot be place in confined areas

To summarize Table 7.3-1, in full scale operations, approved padfoot rollers operated in static mode must be used for soil, and approved smooth drum rollers operated in vibratory mode must be used for all other materials. Exceptions are the use of approved smooth drum rollers operated in static mode only for an initial breakdown pass on soil lifts, and when sealing soil surfaces at the end of work shifts or when a rainstorm is imminent. For confined spaces, approved hand operated equipment must be used on Soil and Granular Type 1 and Type 2 materials. Random, Shale and Rock materials are not permitted to be placed in confined areas. The representative may also consider permitting the use of padfoot rollers in vibratory mode if it is desired to break down shale or other fractured rock types with a laminated structure.

Requirements for different equipment types listed in Table 7.3-1 are provided in the Pub. 408 sections indicated. In general, for a specific equipment type, lighter equipment (i.e., equipment with less mass) will have less contact pressure, be less efficient and require more passes to achieve the required density.

## 7.4 Quality Control, and Acceptance and Verification

### 7.4.1 Acceptance Based on Moisture-Density Control

For materials accepted based upon moisture-density control, the Department requires the contractor to be responsible for quality control and acceptance testing. This includes materials classified as Soil and Granular Material Type 1. This includes a requirement that the contractor submit a QC plan for approval by the Department. Verification testing is conducted by the Department.

#### 7.4.1.1 Testing Frequency

Minimum required quality control, acceptance and verification testing frequencies for moisture-density controlled materials are indicated in Table 7.4-1 below.

Testing Phase	Operation Phase	Material Location		
		Embankment or Fill	Subgrade	Pipe Backfill
Quality Control	Start-up	One QC test per lift for each 500 sy placed w/min 6 tests per lift per day.*	One QC test per lift for each 400 sy placed w/min 8 tests per lift per day.	For every pipe run conduct one QC test for every 50 cy of pipe backfill w/min two tests per lift per day
	Production	One QC test per lift for each 1000 sy placed w/min 3 tests per lift per day.*	One QC test per lift for each 800 sy placed w/min 4 tests per lift per day.	For every pipe run conduct one QC test for every 100 cy of pipe backfill w/min two tests per lift per day
Acceptance	Production	One Acceptance test per lift for each 4000 sy placed w/min one test per lift per day.*	One Acceptance test per lift for each 3000 sy placed w/min one test per lift per day.	For every pipe run conduct one QC test for every 100 cy of pipe backfill w/min two tests per lift per day
Verification	Start-up and Production	One Verification test for every ten Acceptance tests		

\* In small areas, test frequency need not exceed requirements for pipe backfill.

#### 7.4.1.2 Moisture and Density Requirements

Testing is conducted to determine if the compacted material has attained the required minimum dry density, within the allowable moisture range at the time of compaction. Department requirements for percent of maximum dry density and allowable moisture are indicated in Table 7.4-2. Requirements are based upon the maximum dry density and optimum

moisture determined from laboratory moisture-density tests (i.e., proctor test) conducted on representative sample of the material being compacted.

Material	Location	Density	Moisture	Test Method
Soil	Top 3 feet of fill	100% of Maximum Dry Density	Between Minus 3% of Optimum and Optimum	PTM No. 402 using Direct Transmission Method
	Below 3 foot depth	97% of Maximum Dry Density		
Granular, Type 1	Top 3 feet of fill	100% of Maximum Dry Density	+/- 2% of Optimum	PTM No. 402 using Direct Transmission Method*
	Below 3 foot depth	97% of Maximum Dry Density		

\* The Representative may allow the back scatter method to be used if the material is too coarse for the direct transmission method to be conducted effectively.

#### 7.4.1.3 Nuclear Moisture and Density Gauge - Description

The tool for field testing, according to PTM No. 402, is the nuclear moisture and density gauge. The gauge uses two energy emitters (two sources of radiation) and two detectors. One source emits gamma rays and the other emits neutrons. Gamma rays are used to determine material density and neutrons are used to determine moisture. The gauge does not measure moisture or density directly, rather both values are correlated with the level of energy emitted from each source that reaches the detectors.

Gamma rays are a form of electromagnetic radiation. Electromagnetic radiation spectrum includes radio waves, microwaves, infrared, visible and ultraviolet light, X-rays, and gamma rays. Gamma rays have the shortest wavelength in the electromagnetic spectrum, and mostly result from the radioactive decay of atomic nuclei. Gamma rays are very high speed (i.e., the speed of light), are high energy, and have high penetrating power making them especially dangerous. **For this reason, it is very important that any operator be properly trained in the handling, operation and care of a nuclear moisture-density gauge.** There is adequate shielding built into the gauge around the radiation source, so use of the gauge poses no hazard if used properly.

The source of gamma rays in the gauge is typically a small amount of Cesium-137 located in the tip of the source rod (see Figure 7.4-1). The compacted material interacts with the gamma radiation resulting in either a loss of energy or redirecting (i.e., scattering) the energy. Because Cesium-137 has a radioactive decay half-life of approximately 30 years, it is important that the gauge undergo calibration annually, and the gauge be adjusted on a monthly basis for the energy decay.

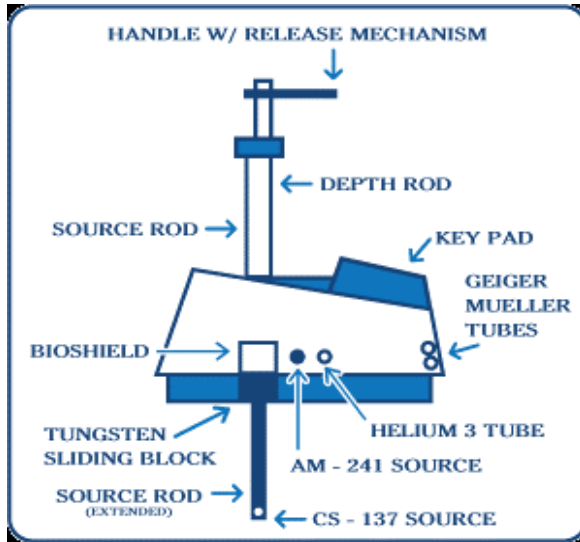

Source: <https://www.apnga.com/industry-info/gauge-basics/>

Figure 7.4-1 – Components of a Typical Nuclear Moisture-Density Gauge

For measuring density, the gauge can function in one of two modes: Direct Transmission or Backscatter (see Figure 7.4-2). The gauge determines the density of the material differently depending upon which mode of operation is used.

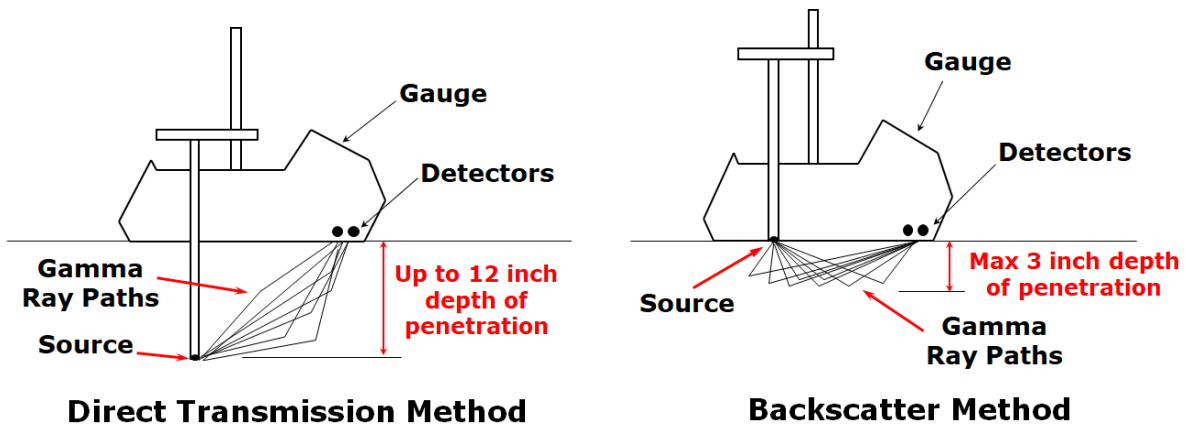

Figure 7.4-2 – Nuclear Moisture-Density Gauge Operation Modes

When in direct transmission mode of operation, the radiation source is lowered down into the compacted material. The detectors measure the amount of gamma radiation emitted by the source that passes through the material. The denser the compacted material, the less energy reaches the detectors. In direct transmission mode, low detection results in the gauge indicating a higher density.

In backscatter mode, the source is at the same level as the detectors. The gauge's shielding prevents radiation from the source from directly reaching the detectors. For radiation

to reach the detectors it must be deflected off the compacted material. The denser the compacted material, the less radiation can penetrate and the more it is reflected and scattered back up towards the gauge. The more gamma radiation reaching the detectors, the higher the material's density.

To summarize, in direct transmission mode, lower amounts of radiation detected equals a higher material density. Radiation and density are inversely proportional in direct transmission. In backscatter mode, higher amounts of radiation detected equals a higher material density. Radiation and density are proportional in backscatter.

A problem with operating the nuclear gauge in backscatter mode is getting an accurate and representative measurement of density for the entire compacted lift. Maximum compacted lift thickness for Soil and Granular Material, Type 1 is six inches. However, as indicated in Figure 7.4-2, the maximum energy penetration in backscatter mode of operation is only 3 inches with average penetration more on the order of two inches. This means that the density measurement is weighted heavily to the upper one third to one half of the compacted lift, typically the most well compacted and densest portion of the lift, since maximum contact pressures are at the material surface.

The direct transmission mode of gauge operation overcomes the limitations of the backscatter method since the source can be lowered to the bottom of the compacted lift. With the source placed at the bottom of the lift during testing, the full lift thickness is "interrogated" by the source energy, yielding a true average value of density for the full lift thickness, not a value weighted towards the portion of the lift experiencing the highest contact pressures during compaction.

The gauge uses a neutron emitting source to determine moisture content. Neutrons are the neutral (no charge) particle from the nucleus of atoms. The travel speed of neutrons is only about 5 percent that of gamma rays, but since the particle has mass, neutron radiation is also very high and penetrating, making neutron radiation very dangerous. Repeating the earlier cautionary statement, **for this reason, it is very important that any operator be properly trained in the handling, operation and care of a nuclear moisture-density gauge.** However, there is adequate shielding built into the gauge around the radiation source, so use of the gauge poses no hazard if used properly.

The source of neutron radiation in the gauge is typically Americium 241. The neutrons emitted by the source interact with the nucleus of hydrogen atoms in the compacted material. The primary source of hydrogen in soil is water. The interaction with hydrogen atoms results in a reduction of energy for the neutron particle, and the particle slows down.

The neutron detectors in the gauge are only able to detect slower neutrons. The higher the moisture content in the compacted material the greater the number of hydrogen atoms. The greater the number of hydrogen atoms results in an increase in the number of slower neutrons and a resulting increase in neutron detections. The rate of neutron detections is proportional to the moisture content. More neutron detections equate to a higher moisture content.

#### 7.4.1.4 Nuclear Moisture and Density Gauge - Operation

##### Gauge Operation – Equipment

In addition to the nuclear gauge, there is a variety of hand equipment required to operate the gauge. The required apparatuses to prepare the site and run the test are and shown in Figure 7.4-3 and listed below.

Equipment required to conduct the field in-place density and moisture content test using a nuclear moisture and density gauge:

- Portable nuclear in-place moisture and density gauge with storage and transport case
- Reference standard block
- Leveling/scrapper plate with drive rod guide
- Drive rod with extraction tool
- Hand sledgehammer to advance drive rod into compacted material
- D-handle square point shovel or garden spade
- Safety glasses

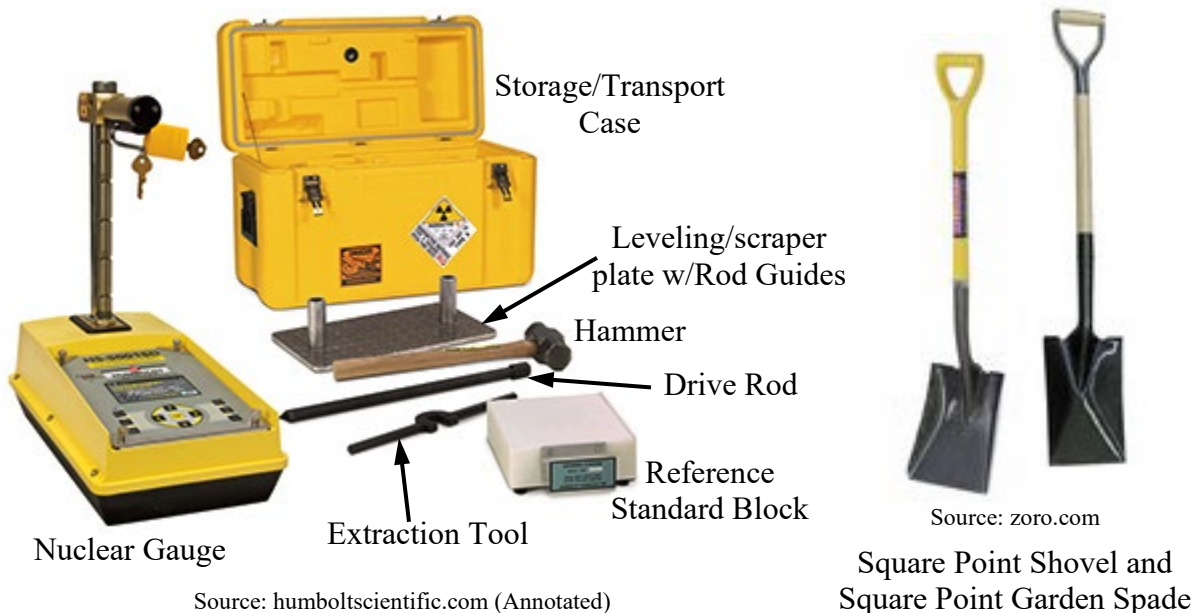

Figure 7.4-3 – Equipment Required to Conduct Field In-place Nuclear Moisture and Density Test

##### Gauge Operation – Backscatter Mode

Only use the gauge in backscatter mode of operation if permitted by the Representative in situations when a hole cannot be formed with the drive pin in Granular Material, Type 1. Although it is not likely that the need would arise, this would be a situation when it is not possible to drive the pin with a hammer to form a uniform vertical hole to the depth required

because the material is too coarse or is deflected from vertical by an oversized particle. If the pin cannot be driven, or is deflected from vertical, try several locations before opting for the backscatter mode of operation. Operate the nuclear moisture-density gauge as per manufacturers recommendations and instructions except where superseded by PTM No. 402 – Determining In-place Density and Moisture Content of Construction Materials by Use of Nuclear Gauges. Turn on gauge and permit to warm up as required.

Prepare the test surface with the leveling/scrapper plate (see Figure 7.4-4). The prepared surface should be smooth and level being free of any depressions or surface voids. If any small surface voids remain because of coarse particles, fill the voids with fine damp sand. It is important to have a smooth level surface so that there are no air gaps between the material being tested and the bottom surface of the gauge. Air gaps prevent efficient and effective transmission of energy between the gauge and compacted material at both the energy source and energy detectors. Good ground contact with the gauge assures proper coupling and energy transfer. Place the gauge on the prepared ground surface, set gauge controls as directed and/or required, and enter necessary information. Start gauge and take readings for the time required.



Source: apnga.com

Figure 7.4-4 – Preparation of Surface with Leveling/Scrapper Plate

### **Gauge Operation – Direct Transmission Mode**

The gauge should be operated in direct transmission mode at all times for Soil and Granular Material, Type 1, except in some possible (but unlikely) circumstances for Granular Material, Type 1 as discussed above. Again, operate the nuclear moisture-density gauge as per manufacturers recommendations and instructions except where superseded by PTM No. 402 – Determining In-place Density and Moisture Content of Construction Materials by Use of Nuclear Gauges. Turn on gauge and permit to warm up as required.

As with backscatter mode of operation, prepare the test surface with the leveling/scrapper plate. The prepared surface should be smooth and level being free of any depressions or surface voids. If any small surface voids remain because of coarse particles, fill the voids with fine



damp sand. It is important to have a smooth level surface so that there are no air gaps between the material being tested and the bottom surface of the gauge. Air gaps prevent efficient and effective transmission of energy between the gauge and compacted material at both the energy source and energy detectors. Good ground contact with the gauge assures proper coupling and energy transfer.

Once the surface has been satisfactorily prepared, place the leveling/scrapper plate on the compacted surface. Lightly score a line in the surface around the edge of the scraper plate (see Figure 7.4-5). This will later serve as a guide for placement of the gauge. Slide the extractor tool onto the drive rod and insert the drive rod in the plate rod guide (see Figure 7.4-6). Drive the rod to the desired depth with the hammer. Drive the rod approximately one inch deeper than the desired or required measurement depth to assure there is no interference at the bottom of the hole and the gauge source rod. Carefully extract the rod from the compacted material by pulling the rod up vertically while rotating the extractor tool back and forth (i.e., clockwise and counterclockwise). Remove the base plate. The process should produce a vertical smooth hole of the required depth with a diameter slightly larger than the gauge source rod.



Source: apnga.com

Figure 7.4-5 – Scoring Around Scraper Plate for Proper Alignment of Source Rod with Hole



Source: apnga.com

Figure 7.4-6 – Drive Rod in Plate Guide Hole with Extractor Tool

Place the gauge on the surface of compacted material, using line that was lightly scored around the plate as a guide. Make sure to align the gauge so that the source rod lines up with the hole. The gauge source rod should travel freely down the hole if the gauge is aligned properly. Release the rod locking mechanism and insert the gauge source rod down to the required depth and reengage the source rod lock.

**Caution – Never lift up the gauge and open the gauge bio-shield exposing the source rod to visually align the source rod with the hole (see Figure 7.4-7). This will result in potentially dangerous unnecessary unshielded exposure to the radiative source. Use the scraper plate to create a template for gauge placement and proper rod alignment by lightly scoring or tracing around the edge of the plate immediately prior the hammering in the drive rod.**



Source: apnga.com

Figure 7.4-7 – **DANGER – Never Expose Source Rod**

Once the source rod has been inserted down into the hole to the required depth and locked in place, it is important to then pull the entire gage backward (see Figure 7.4-8) to assure contact of the tip of the radioactive source rod with the compacted material. It is necessary that there are no air gaps between gauge energy sources or detectors and the compacted material in order to assure proper coupling and energy transfer. Once the gauge has been properly positioned with good source and detector contact, set the gauge controls as directed and/or required and enter necessary information. Start gauge and take readings for the time required.

### Direct Transmission

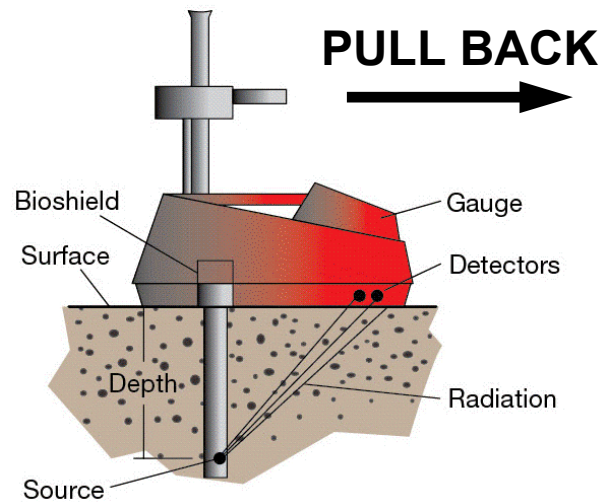

Source: <https://www.nrc.gov/images/materials/miau/density-gauge.gif>

Figure 7.4-8 – Coupling of Gauge Source Rod with Compacted Material for Effective Energy Transmission

#### 7.4.1.5 In-place Moisture and Density Testing with Nuclear Gauge – PTM No. 402

The test method used for determining in-place moisture and density using a nuclear gauge is PTM No. 402 – Determining In-place Density and Moisture Content of Construction Materials by Use of Nuclear Gauges. PTM No. 402 is a modification of AASHTO T 310, and as stated previously, is only used for Soil and Granular Material, Type 1 as defined in Publication 408, Section 206.2(a), Embankment Material. PTM No. 402 follows AASHTO T 310, except for gauge standardization and a modification to the direct transmission procedure.

Standardization for Troxler manufactured gauges can be performed using PTM No. 418 or the requirements and procedures for standardization in AASHTO T 310. The Department's internal forces use only Troxler gauges so PTM No. 418 is written exclusively for Troxler equipment. Gauges from any other manufacturer must be standardized using the AASHTO T 310 requirements and procedures.

The direct transmission procedure detailed in PTM No. 402 is a modification to the procedure listed in AASHTO T 310. The direct transmission procedure in PTM No. 402

involves taking multiple readings from one location (see Figure 7.4-9). Once the source rod is lowered into the hole, three one-minute readings are taken. For each reading, the nuclear gauge is rotated 90 degrees from the previous position. Each one minute reading is considered an individual test increment for the location. The final moisture and density values for the test location are simply the numerical average of the three individual results. Since the gauge detector is located in a different position during each test increment, three different masses of soil are actually tested from the same source hole. Taking the average of the three test increments serves to “soften” the impacts of material and test variability, providing a more representative final test result for the completed work.

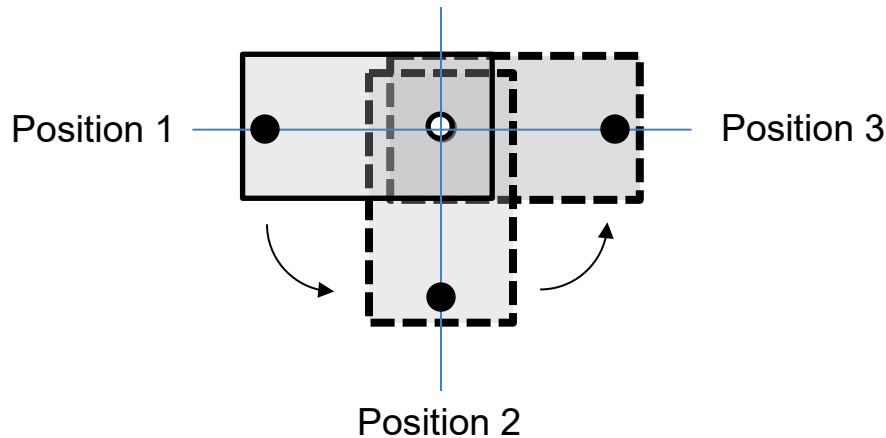

Figure 7.4-9 – PTM No. 402 In-place Nuclear Moisture and Density Test Increment Procedure

## 7.4.2 Acceptance Based On Non-movement

While placement, compaction and acceptance of Soil and Granular Material, Type 1 are controlled by moisture and density, all other materials are accepted based on a condition of non-movement of the material under the compactor as determined by the Department's Representative as specified in Pub 408, Section 206.3(a)3. This includes the following material types as defined by Pub 408, Section 206.2(a), Embankment Material: Granular Material, Type 2; Rock; Shale and Random Material.

## 7.5 Operational Considerations and Potential Problems

This section presents a number of specific topics that involve or are related to field operations. The topics include the following listed situations and conditions:

- Moisture-Density – Going from the lab to the field
- Achieving more than 100% compaction
- Monitoring and controlling lift thickness with the nuclear gauge
- Build-up of soil on drum between rows of pads on padfoot roller
- Defining non-movement
- The problem soil – non-plastic silt
- Drainage

### 7.5.1 Moisture-Density – Going from the Lab to the Field

As was discussed in Chapter 4, the moisture-density relationship of a soil is dependent on three variables: the soil characteristics (gradation and mineral types), water and the type and magnitude of the compactive energy. Thus, for a given soil the moisture-density relationship will change as the compactive energy changes. In general, the relationship is as the compactive energy increases, the maximum dry density increases and the optimum moisture content decreases (see Figure 7.5-1).

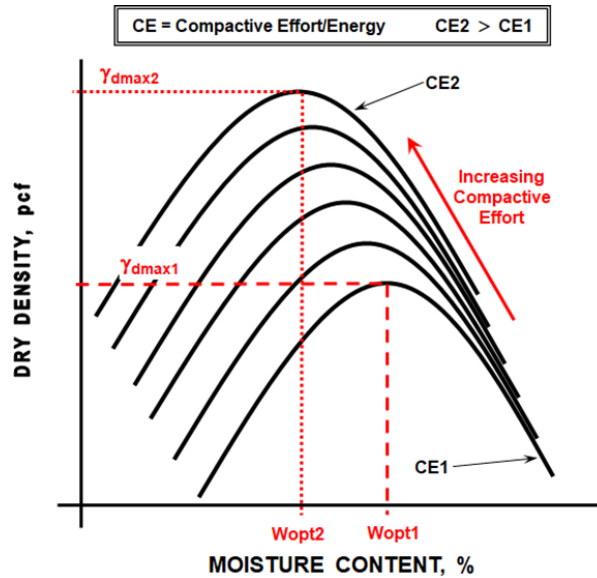

Figure 7.5-1 – Effect of Compactive Effort on Moisture-Density Relationship of Soil

There are some specific differences in the conditions of how soil is compacted in the lab when conducting a moisture-density test, and how it is compacted in the field during full scale production. These differences lie primarily in the boundary conditions and in the nature and magnitude of the compactive energy applied.

Relative to boundary conditions, in the lab the sample is compacted in a rigid wall steel mold. The rigidity of the mold provides for more efficient transfer of energy from the compaction device (i.e., the proctor hammer) to the soil. In the field, the material being compacted is typically surrounded by material of the same type, or in the case of a pipe trench, other earth materials. In either case, the surrounding materials are not of the same rigidity as the steel mold used in the lab. This results in a slight reduction in efficiency in energy transfer from the compaction equipment to the material being compacted. In practice, the loss is small and if energies used in the lab and the field were identical, would simply require slightly more cycles of energy application.

In practice, the type and magnitude of energy applied in the lab versus the field are quite different. Even in the field, the type and magnitude of different types of compaction equipment is very different (as discussed in Chapter 5). Compaction equipment varies in physical geometric size, mass, contact area and contact area geometry. Contact pressures and the area being loaded can vary significantly between equipment. The nature of how energy is applied can also vary

significantly from statically applied loads (i.e., padfoot roller), relatively low frequency dynamic loads (i.e., tamper/rammer), to high frequency dynamic loads (i.e., vibratory rollers and vibratory plate compactors). In the lab, energy is very low frequency, approximately one blow per second or 1 Hz, dynamic load applied by drops of the proctor hammer.

While correlations are possible between equipment of similar configuration and operation (e.g. between different size/energy smooth drum vibratory rollers, different size/energy vibratory plate compactors, different size tampers, and different size and geometry padfoot rollers), correlations in energy between the different types of field compaction equipment is extremely difficult at best. As for lab testing, the closest correlation to the proctor hammer to any field operation and equipment is the hand operated tamper/rammer.

It is easy to infer that the moisture-density relationship developed from lab testing is likely not completely representative of field operations. This does not imply that compaction control using the moisture-density relationship is not practical and valid, rather that there is simply a difference in how the final results are achieved. It is important to recognize that there is a difference for proper and effective development of specification operational and performance requirements.

While the performance requirements for moisture and density do not change, it is the differences described above that are the very reason the type of compaction equipment must be selected according to the material being compacted. It is also the basis for Department specifications restricting the use of certain equipment to compact some materials, and requiring specific equipment types for other materials. For example, the requirement of padfoot rollers for soil and vibratory smooth drum rollers for granular materials, aggregate and rock.

Such restrictions and requirements, while they may deviate somewhat from a completely performance based specification, prevent situations where performance requirements might be impossible to meet without certain operational restrictions. This brings us to the often forgotten, neglected and/or ignored Department performance requirement for compaction – **stability**.

Publication 408, Section 206.3(c) – Stability, states “Assume responsibility for the stability of embankments and fills.” Stability is the third performance requirement. It is not sufficient to simply place and compact the material within the allowable moisture band to the required minimum density, but the contractor must also achieve and **maintain** a stable condition.

Permitting the use of compaction equipment that would result in or create an instability in the compacted material would be counter productive, present a weakness and vulnerability in the specification, and result in unnecessary risk to the Department. An example of this will be presented in a later section of this chapter. Following the specifications of Pub. 408, Section 206, all three requirements, moisture, density and stability, must be achieved and maintained for acceptable completion of work.

## **7.5.2 Achieving More Than 100% Required Density**

There are several situations or causes resulting in a condition where greater than 100 percent of the maximum dry density from lab moisture-density testing is achieved. For the first case we will assume that moisture-density testing was conducted on a sample representative of

the material being compacted. For such a situation, referring to Figure 7.5-2, the direct implication of achieving greater than 100 percent of the maximum dry density is that the material was compacted wet of optimum moisture. This does not mean the material was actually placed at a moisture above what the allowable moisture band permits. Rather, the compactive energy applied exceeded the compactive energy of the standard moisture-density lab test that produces the target moisture and density for placement and compaction.

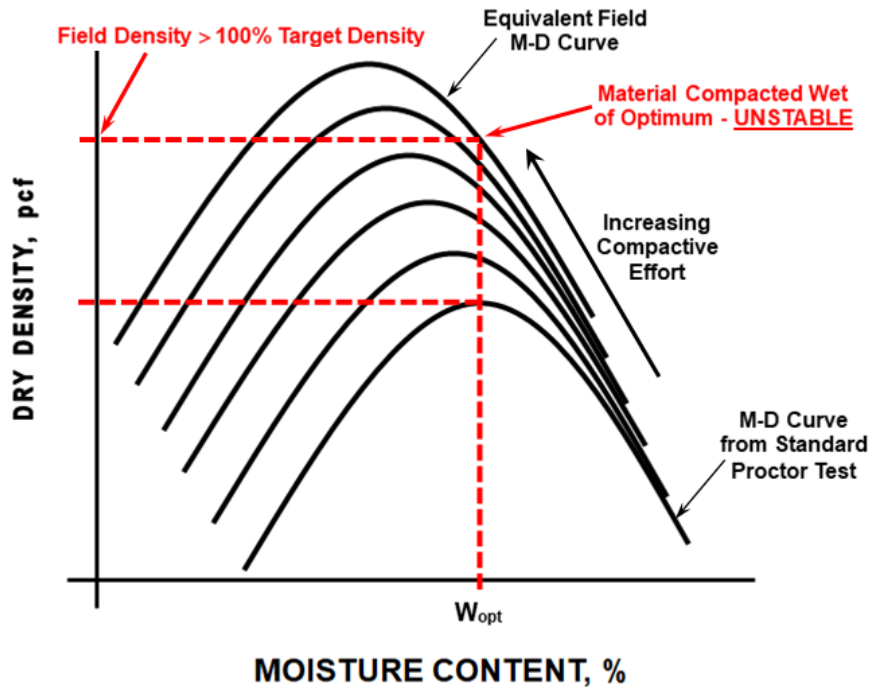

Figure 7.5-2 – Compactive Energy at Wet of Optimum Moisture

As indicated by Figure 7.5-2, as compactive energy increases, the maximum dry density increases and the optimum moisture decreases. If excessive energy is applied in a field operation, a density higher than the lab maximum dry density is obtained. However, if the moisture content during placement and compaction is consistent with the optimum moisture achieved during lab testing, the material will actually be wet of optimum moisture for the corresponding for the energy applied in the field. In addition, the material density achieved will not correspond to the maximum density that could be achieved for that for material for the compactive energy applied. The result is frequently an unstable condition where the material deforms excessively under load and/or a shear wave develops in front of and behind the roller.

Another condition that could result in greater than 100 percent of the target maximum dry density is that the material being compacted is no longer consistent with the sample tested in the lab. The target moisture and density values are no longer valid. In this situation, it is impossible to know if the material was placed and compacted at the proper moisture content, and what percent of maximum dry density was achieved. As was discussed previously, any indication in changes in the material being placed signifies the need to collect and send a new sample in for testing. There is a need to determine if the moisture-density relationship being used is valid for the material being placed. Changes in the density being achieved, whether an increase or

decrease, without any operational or equipment changes, is an indication of a possible material change. Other indicators include physical appearance such as change in color or texture.

### **7.5.3 Monitoring and Controlling Lift Thickness with the Nuclear Gauge**

Aside from producing more representative test results, one of the advantages of performing moisture and density testing with the nuclear gauge in direct transmission mode is the ability to actively monitor and control lift thickness. Direct transmission mode of testing can be conducted with the source rod at depths of up to twelve inches. Maximum compacted thickness of materials controlled by moisture-density is six inches. If lifts are being placed and compacted at the required lift thickness, then very nearly the same average density would be obtained in testing were conducted with the source rod at depths of six, nine or twelve inches, and any other depth in between.

At a depth of nine inches, the tip of the source rod should be in the middle of the previously placed lift. The density should be the same with the rod at a depth of six inches, or maybe slightly higher, since the upper portion of the previous lift would be the portion subject to higher stresses when that lift was compacted, resulting in possibly a bit higher density in the upper portion of the lift. At a depth of twelve inches, the tip of the source rod should be at the bottom of the previously compacted lift. The density at the twelve inch depth should be very nearly the same as at the six inch depth.

However, if lifts are placed to a completed compaction thickness exceeding six inches, then the density should start to decrease with depth. Say for example a ten-inch compacted lift were placed. With the source rod at a depth of nine inches, the density should decrease from the density achieved at six inches. At nine inches, the compacted ten-inch lift would have been subject to less pressure than at six inches, resulting in a lower average density of the lift when measured from the nine-inch depth. If the source rod were then advanced to a depth of twelve inches and a test conducted, this would place the radioactive source in the top of the previous lift. At this depth, with the ten inch compacted lift, the measured density should exceed the density that was measured at the nine inch depth. Whether the measured density would be the same as at the six inch depth, or somewhere between the values at six inches and nine inches is not certain.

If a twelve inch compacted lift were placed, the density should continue to decrease as the depth of the source rod is advanced (from six, then to nine, then to twelve inches). Using this approach and procedure, it is possible to monitor if the compacted lift exceeds the allowable thickness, and inadequate density is being achieved for a portion of the material placed.

### **7.5.4 Build-up of Soil on Drum Between Rows of Pads on Padfoot Roller**

It is important to keep the drum of any roller clean. Build-up of material on the surface of a roller or other compaction device interferes with effective development of contact pressures and transmission of energy. Smooth drum rollers typically have a scraper attachment that keeps the roller drum clear of any material build-up (see Figure 7.5-3).





Source: [https://photos.smugmug.com/Construction-Galleries/Construction-Earth-Moving-Cut/i-bqGPXJg/1/48f7b5c9/M/roller\\_2250-M.jpg](https://photos.smugmug.com/Construction-Galleries/Construction-Earth-Moving-Cut/i-bqGPXJg/1/48f7b5c9/M/roller_2250-M.jpg) (Annotated)

Figure 7.5-3 – Scraper on Smooth Drum Roller

Similarly, padfoot rollers have scraper tines that are located in the gaps in between the roller pads (see Figure 7.5-4). The tines work adequately to clean the drum in between the pads, however, soil can build up in the gaps between the pads around the circumference of the drum (see Figure 7.5-5). If this happens, there are two issues of concern. First, it is a clear indication that the soil being compacted is likely a plastic material and is too wet (i.e., above optimum moisture). The second problem is that as the soil builds up it is not only interfering with penetration of the pads, but also effectively and significantly reducing the contact pressure of the pads by support a substantial portion of the mass of the roller. When this condition is observed, the soil needs to be dried back to within the required placement and compaction moisture limits and the build-up of soil needs to be cleaned from between the drum pads. The soil can be scarified and aerated to facilitate drying of the material.



Source: <https://st.mascus.com/imagetilewm/product/22234e97/caterpillar-padfoot-kit-for-cs,27f66700.jpg> (Annotated)

Figure 7.5-4 – Padfoot Roller Scraper Tines (Between Pads)

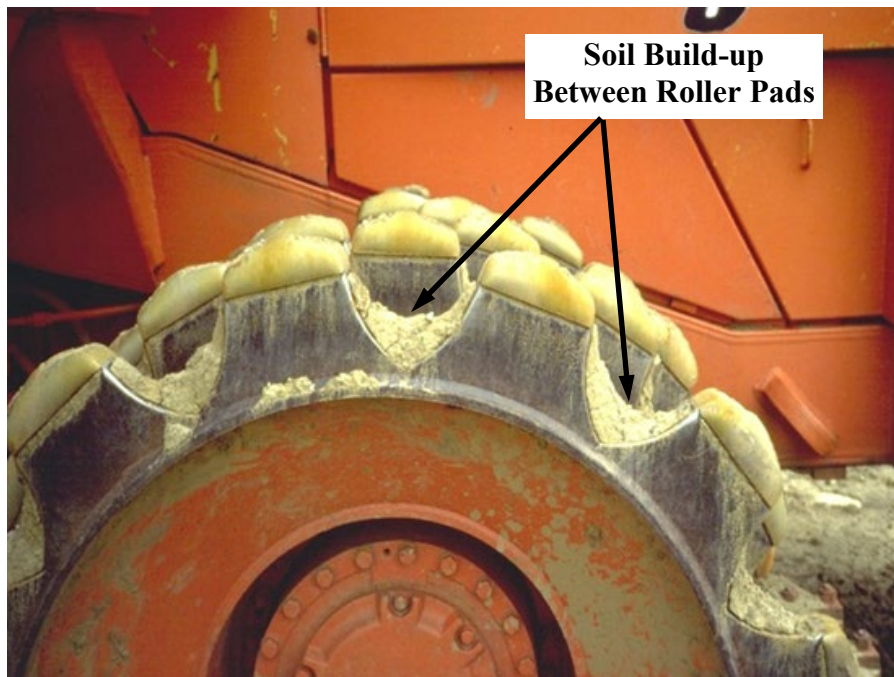

Source: Unknown (Annotated)

Figure 7.5-5 – Soil Build-up Between Padfoot Roller Pads

### 7.5.5 Defining Non-movement

Interpreting the “condition of non-movement” depends on the type of material being compacted, and the nature and magnitude of the movement observed. We will consider no-movement separately for fine-grained soil and granular materials. Fine-grained soils are defined by Publication 408, Section 206.2 – Soil, and granular materials are defined by Publication 408, Section 206.2 – Granular, Types 1 and 2 (Granular, Type 2 includes manufactured coarse aggregates).

Any material subjected to a load will deform. It is a basic engineering principle known as stress-strain. A material subjected to stress will experience a corresponding level of strain. The strain is observed as deformation or simply movement. The magnitude of the deformation resulting from a load is a function of the material’s stiffness. The stiffer the material, the less the deformation.

The ratios of the load and stiffness can be such that the resulting deformation can be so small as to be from a practical sense imperceptible. Think of a single sheet of paper placed on top of a desk; while visually imperceptible, deformation of the desktop does occur. So long as the load does not result in permanent deformation or disturbance of the internal structure of the material, the deformation is considered elastic.

During compaction, all materials will experience deformation. It is the type and magnitude of deformation that is important to consider. Deformations that result in volume change are desirable, beneficial and productive. Such deformations are the primary goal of compaction operations – a reduction of air voids.

For fine-grained materials, large initial permanent deformations are both expected and desired. It is the major portion of the process of reducing air voids necessary for volume change. It is as the compaction process is nearing completion that attention must be given to the nature and magnitude of the movement being observed.

For fine-grained soils, there are two types and magnitudes of movement that can be observed (see Figure 7.5-6). In part (a), or left side of the figure, is movement from purely elastic deformation. This is movement consistent with stress-strain or purely elastic deformation under load. The movement is small limited to deflection directly below the roller drum, and there is no heave or other movement beyond the limits of the roller drum contact area. This would be assessed as a condition of non-movement. In part (b), or right side of the Figure 7.5-6, deformation is of greater magnitude and extends laterally beyond the contact limits of the roller drum. While there is vertical downward deflection beneath the drum, there is upward heave on either side (e.g., in front of and behind) the roller drum. This is consistent with general shear of the soil mass beneath and on either side of the roller. Particles are not simply deflecting vertically under load, but are sliding past one another (i.e., shearing). This results in a weakening of the soil mass and instability under load. Stability and a condition of non-movement were not achieved.

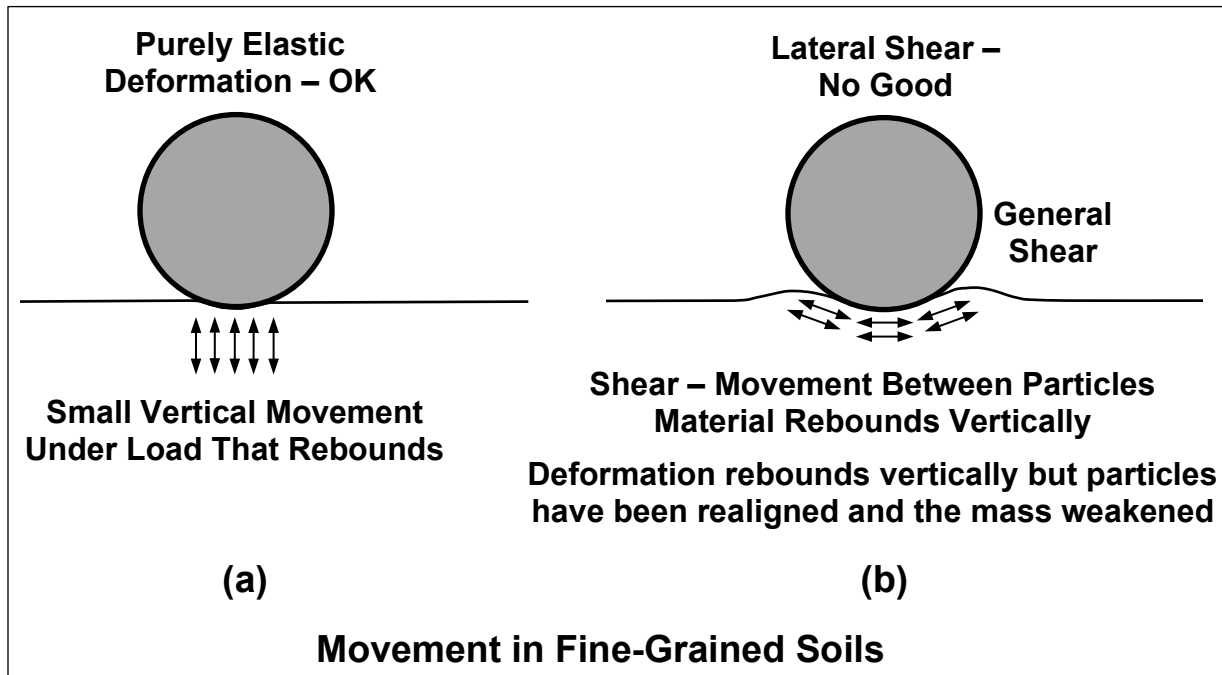

Figure 7.5-6 – Defining Non-movement in Fine-Grained Soils

For coarse-grained or granular materials, there are again two types and magnitudes of movement that can be observed (see Figure 7.5-7). In part (a), or left side of the figure, is movement from purely elastic deformation and is consistent with stress-strain or purely elastic deformation under load. The movement is very small and is limited to deflection directly below the roller drum, and there is no heave or other movement beyond the limits of the roller drum contact area. This would be assessed as a condition of non-movement. In part (b) or right side of the Figure 7.5-7, deformation is of greater magnitude and may extend a short distance laterally beyond the contact limits of the roller drum. The movement is all vertical downward deflection beneath, and possibly immediately in front of and behind, the roller drum. The problem is most likely not with the current layer being compacted, but with underlying layers of material (probably soil).

With granular material the elastic deformation will be even less than that observed for fine-grained soil. The more coarse-grained the material, the lower the magnitude of anticipated elastic deformation. Manufactured coarse aggregates generally experience very little observable deformation.

A Granular, Type 1 material (i.e., sandy soil) approaching a fines content of 20 percent can potentially yield some instability which may be indicated if the observed deflections are not excessive. However, if the lift consists of coarser material (Granular, Type 2 material including gravel or coarse aggregate or other coarser material), the movement is likely an indication of instability in layers below the current lift. Stability and a condition of non-movement were not achieved, and again, the source of the problem lays below the current lift. It is good practice to

proof roll any time coarse materials will be placed and compacted over fine-grained materials, including soil foundations and subgrades.

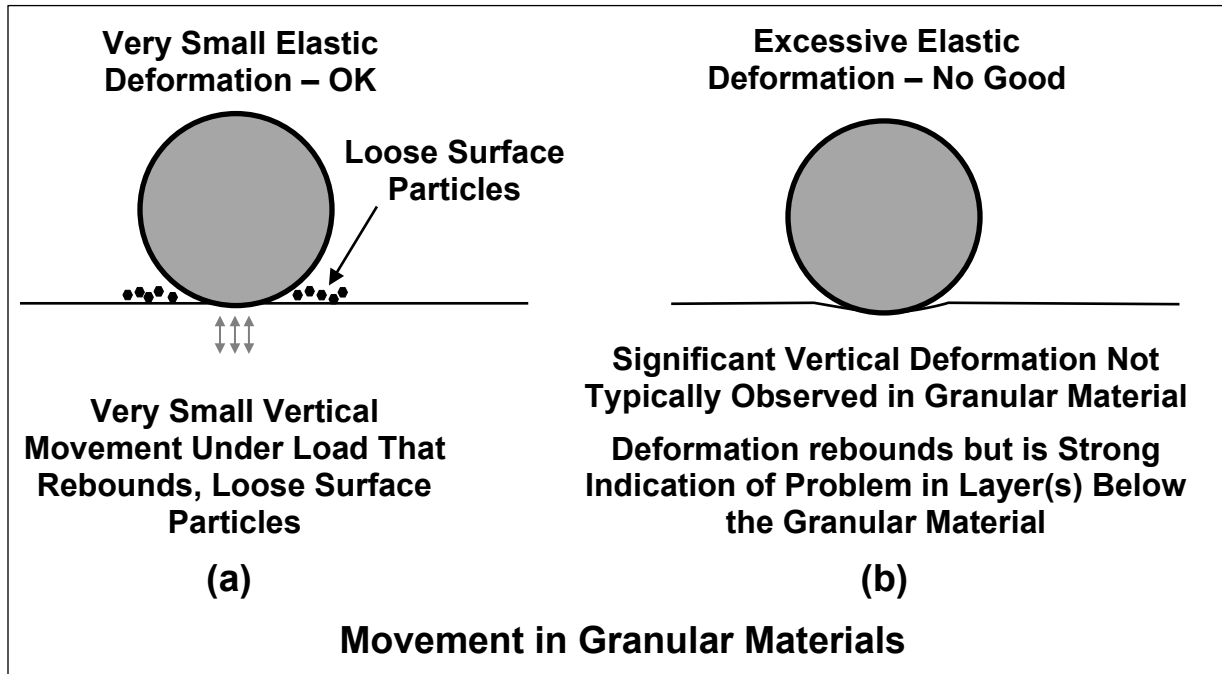

Figure 7.5-7 – Defining Non-movement in Granular Materials

### 7.5.6 The Problem Soil – Non-plastic Silt

Although discussed previously in Section 3.7, due to their prevalence in Pennsylvania and the problems associated with low to non-plastic silts, it is worth emphasizing this material again. This includes soil with fines content of greater than 20 percent, where the fines are low to non-plastic ( $PI = 0$  to 6). This would include materials with an AASHTO soil classification of A-4 and an A-2-4 soils with at least 20 percent fines.

The non-plastic fines are composed of silt. Silt is essentially extremely fine-grained cohesionless material. Because they are so fine-grained, silts exhibit a low permeability resulting in poor drainage performance. However, since they lack plasticity, they have no cohesive binding that would provide internal stability. As a result, these materials can exhibit sensitivity to moisture. Small changes in moisture content result in large changes in dry density (see Figure 7.5-8).

Relative to compaction, high silt content materials (i.e., 20 percent or more fines), with no plastic fines component (i.e. no clays), are the most difficult materials to work with. The low permeability results in poor dissipation of internal pore pressures due to compaction. The resulting excess pore pressures want to push soil particles apart, and with the lack of any cohesive binding the materials easily become unstable, especially if vibratory compaction methods are used. Requiring soil to be compacted using a padfoot roller in static mode helps address the problems associated with moisture sensitivity.

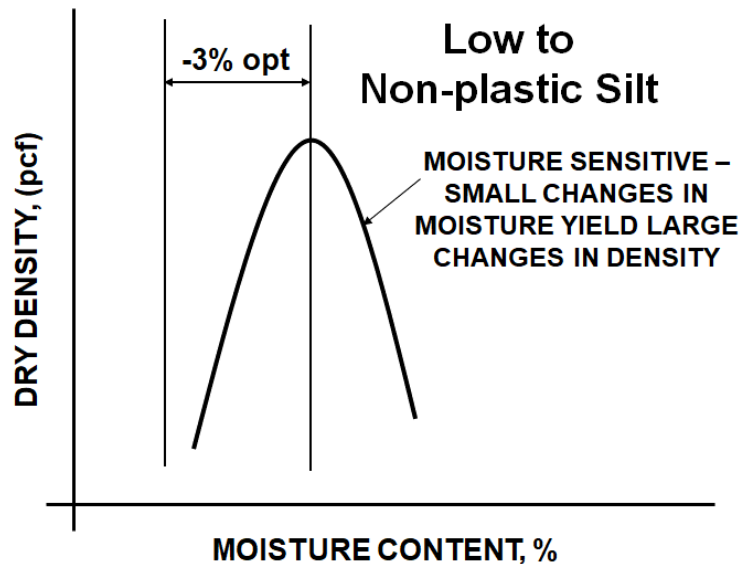

Figure 7.5-8 – Moisture Sensitivity of Low- to Non-plastic Silts

It is important to recognize that soil fines are very significant relative to the behavior and performance of a material. Some fines are plastic and some are non-plastic. Both the fines content (i.e., % fines) and the nature of the fines (i.e., plastic vs. non-plastic) are important in assessing anticipated material behavior. This is because the fines content of a soil will always disproportionately control the strength, behavior, and performance of the material. When it comes to soil properties, a little bit of fines goes a long way.

### 7.5.7 Drainage

This is another issue which has been touched upon in several sections of this manual, but is so critical that it requires emphasis. No matter how much attention is given to achieving good compaction, without care for proper and effective drainage, both short- and long-term performance will be impacted. This is especially the case for pavement subgrades which serve as the foundation for all pavement structures.

As has been discussed, water is an incompressible material. Push on water and without a place to flow or escape, water will push back with equal force. It is the basis for gaining mechanical advantage with hydraulic mechanisms such as a hydraulic piston (e.g. a simple bottle jack). Water trapped in soil voids generates excess pore pressure, which as we have seen reduces the shear strength of the material by approximately 50 percent.

For coarse-grained materials, the issue of drainage is addressed inherently by nature of their high permeability. So long as there is an exit pathway (i.e., someplace for the water to flow), water entering the void space of coarse-grained materials will pass freely. The same does not exist for fine-grained materials. Due to their low permeability, water entering soil voids

cannot exit freely when load is applied. Under load, the water pushes back against the soil particles reducing the stress between the particles, decreasing the shear resistance and shear strength (see Figure 7.5-9).

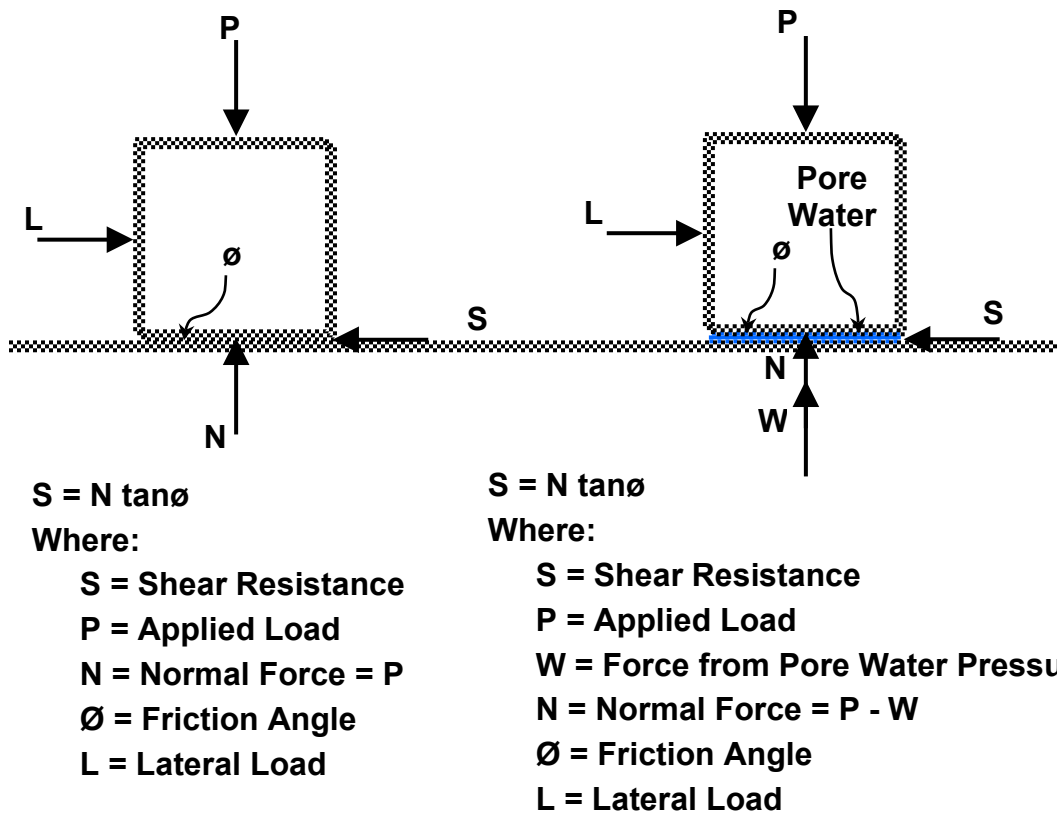

**With pore water pressure the normal force, N, is reduced ( $N = P$  without pore water pressure vs.  $N = P - W$  with pore water pressure. As N is reduced, then  $S = N \tan \phi$  is reduced, but the friction angle remains the same.**

Figure 7.5-9 – Impact of Pore Water on Shear Strength

Since fine-grained soils are the materials more susceptible to strength loss due to water, good compaction provides a measure of protection since it forces particles tighter together, thereby reducing permeability. Low permeability impedes the infiltration of water, but it must be accompanied by proper grading. Surfaces must be graded to shed water to a drainage collection point. Materials must also be graded and compacted with a smooth uniform surface to prevent the collection of water in low areas. Finally, since soils are required to be compacted with a padfoot roller, it is important to level the surface at the end of work shifts and prior to rainstorms with a smooth drum roller in static mode. This helps seal the surface and level indentations and low spots left by the roller pads.

## 7.6 Summary of Field Operations

This section presents a short summary of Chapter 7 – Field Operations, and other more critical issues covered in the manual, in bullet list form. It is intended to serve as a quick reference.

- When compacting soil, there is a moisture-density relationship that is a function of the material type, the compaction effort and the soil moisture. For a given soils type and compactive effort, the material will achieve a maximum dry density and optimum moisture content. As the compactive effort increases, the maximum dry density will increase, and the optimum moisture content will decrease.
- Material must be compacted with the proper type of equipment delivering the compactive energy in the form most productive and efficient for the material being compacted. The equipment used must be selected according to the material being compacted. Soil (i.e., material with  $\geq 20\%$  passing the No. 200 sieve) must be compacted in static mode with a padfoot roller. Granular material (i.e., sand and gravels with less than 20% percent passing the No. 200 sieve, manufactured aggregates and broken rock) must be compacted with a smooth drum roller in vibratory mode.
- Place lifts of uniform material type.
- Place material in uniform lift thickness that with not exceed the allowable compacted thickness for the material type.
- When following moisture-density control for Soil and Granular Material, Type 1 materials, place the material within the allowable moisture band relative to the optimum moisture content.
- Compact materials uniformly – use the same number of roller passes over all areas and compact to a uniform density.
- For Soil and Type 1 Granular Material, check for required density and moisture using a nuclear gauge operated in direct transmission mode.
- Maintain roller speeds during compaction not exceeding one mile per hour (1 mph) or 1.5 feet per second (1.5 fps).
- Grade materials to drain with a uniform surface (no low spots).
- Seal soil surfaces with a smooth drum roller operated in static mode at the end of work shifts and when a storm is approaching.
- It is not sufficient that only required density is achieved, the material must also be stable. Stability must be maintained through completion of the project, and any damage from weather or equipment must be repaired.





**pennsylvania**  
DEPARTMENT OF TRANSPORTATION