

PennDOT

(Pennsylvania Department of Transportation)

ABCs

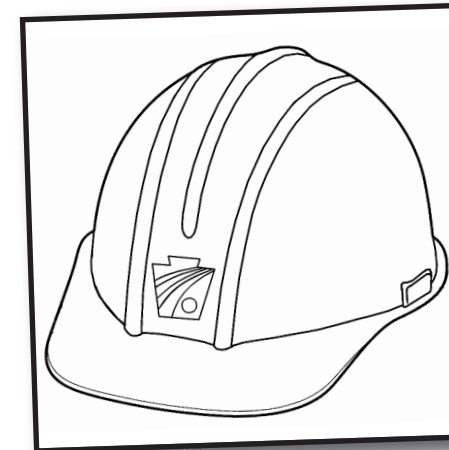

CROSSWORD PUZZLE ANSWERS

DOWN

1. litter
2. hardhat
4. cinders
5. potholes
8. truck
12. loader
13. pipes
16. Monroe
17. office
20. storm
22. flat

ACROSS

3. blacktop
5. PennDOT
6. grader
10. roads
11. budget
14. concrete
15. bridges
18. flaggers
19. signs
21. coffee break





ZONES



Work Zone ahead and oh what a clatter. Let's slow down to see what's the matter. It's one lane of traffic; you might have to wait; but please be patient, you won't be late. Signs and barrels, flags and cones, you're passing through a busy work zone. Jackhammers rattle and engines roar, banging, clanging and honking of horns. It's quite a project to fix these roads; we put down blacktop load after load. Work zones protect us and give us a place where we can work and still be safe.

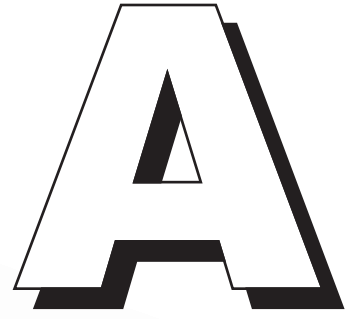

AIRPLANE

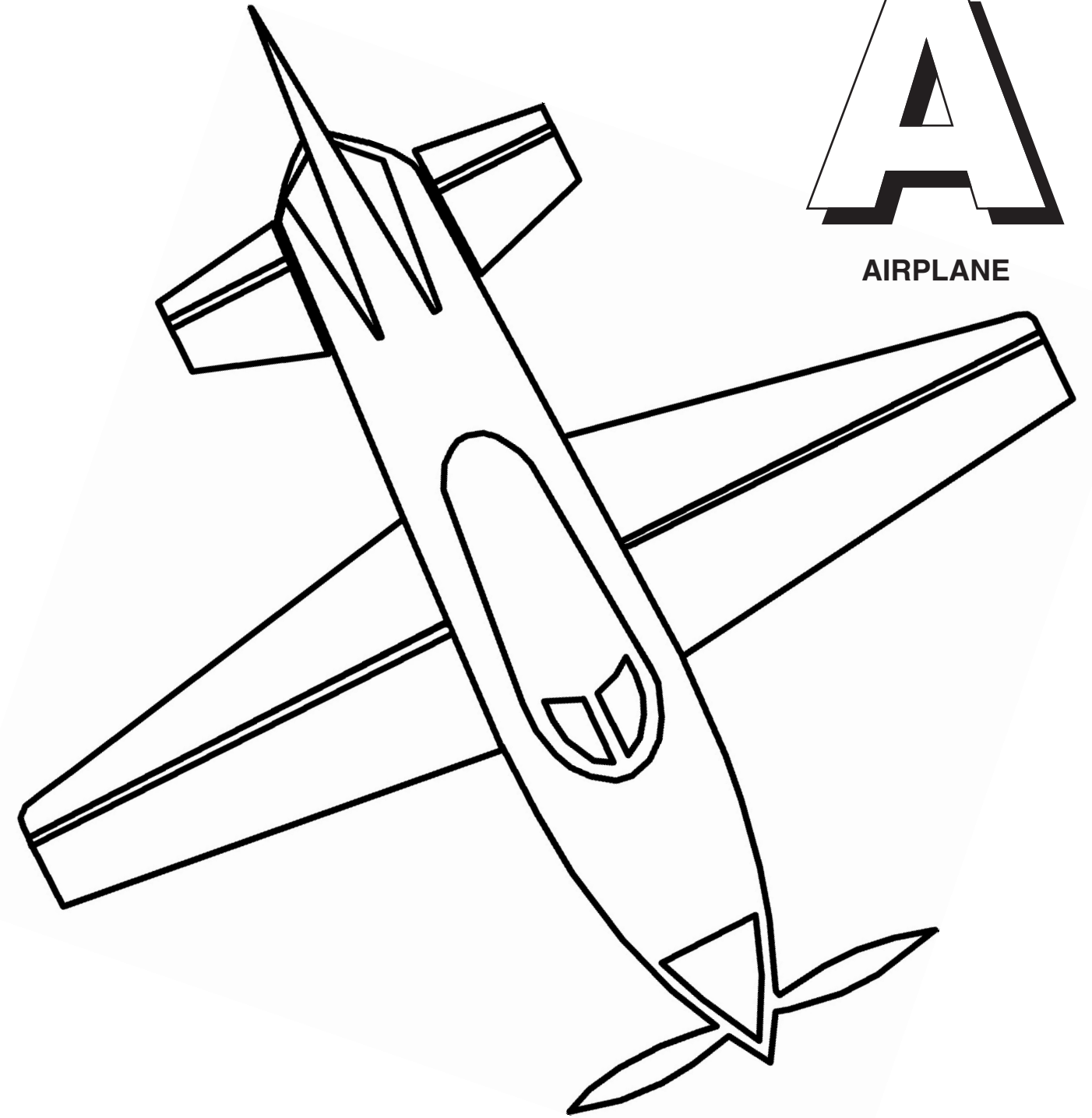

Airports are fun! Wonder what makes the airplane fly? The runways are like big highways, but only the baggage carriers and fuel trucks get to drive on them. Airplanes land and take off on them.

B

BRIDGES



Bridges are very important. When you are taking a ride, if you come to a river, it'll get you to the other side. They go over train tracks, cities, creeks and roads. There are big draw bridges that open for boats. They have to be strong and given lots of care, because bridges are roads that hang in the air!

Y

YELLOW

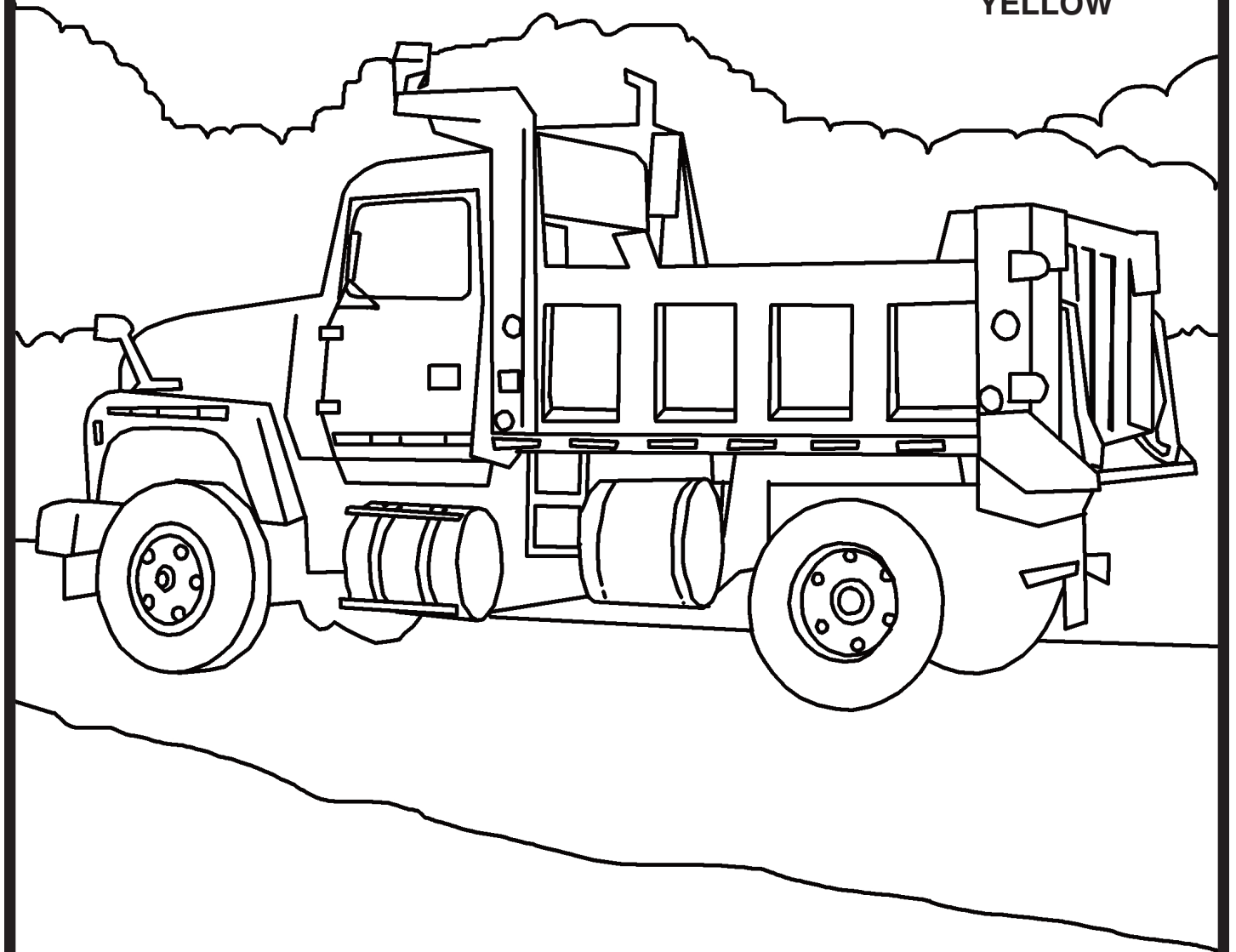

Yellow is the color of PennDOT equipment. Yellow, yellow, why are we yellow? Why couldn't we be a color more mellow? We surely do stand out in the crowd; we know our hue is very loud. It's way too bright and hard on the eyes, but you must admit we're easy to find. We're moving slower than we want to be, and yellow makes us easier to see!



“X”
CROSSWORD
PUZZLE

DOWN

- 1. Careless drivers throw this out of their vehicle windows
- 2. Highway workers wear this to protect their heads
- 4. Trucks spread _____ for traction on icy roads
- 5. Some call these craters in the roads
- 6. Broken down vehicles are taken here for repair
- 8. A large plow is hooked to the front of this
- 12. This piece of equipment fills trucks with salt
- 13. _____ are installed to carry water from one side of the road to the other
- 16. This county is the second-fastest growing in Pennsylvania
- 17. After a day's work, all the paperwork is sent here
- 20. Severe weather condition
- 22. Debris on the road can cause a _____ tire

ACROSS

- 3. We surface old roads
- 5. Pennsylvania Department of Transportation abbreviation
- 6. This piece of equipment has a push blade under its belly
- 10. Maps show which _____ to use
- 11. Activities must be planned so that expenditures remain within our _____
- 14. Material used for sidewalks and roads
- 15. _____ safely carry vehicles over creeks and rivers
- 18. _____ are responsible for traffic control on the job
- 19. Destinations and speed limits are posted on these along our roadways
- 21. We appreciate a 15-minute pause in work to enjoy this _____

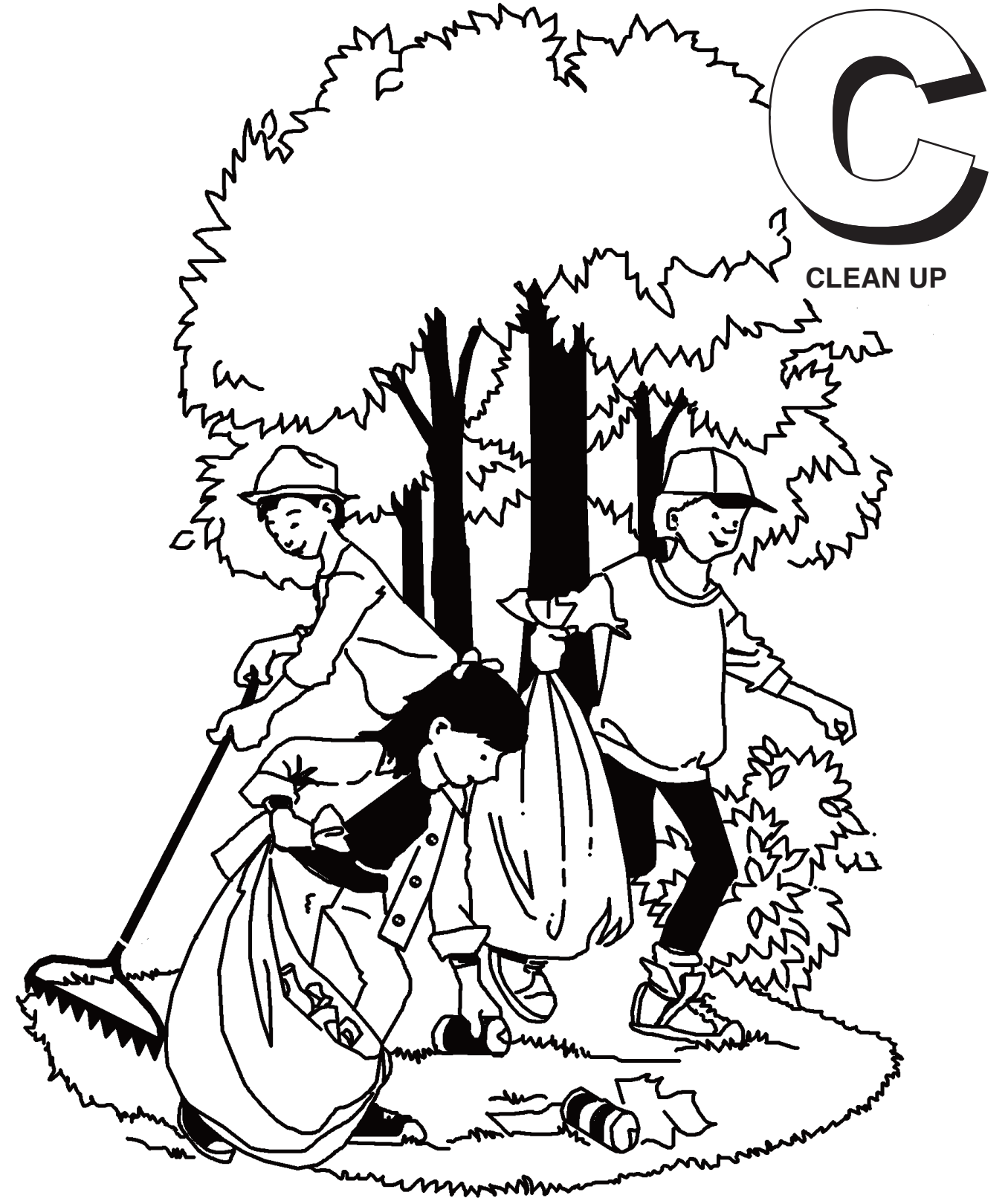
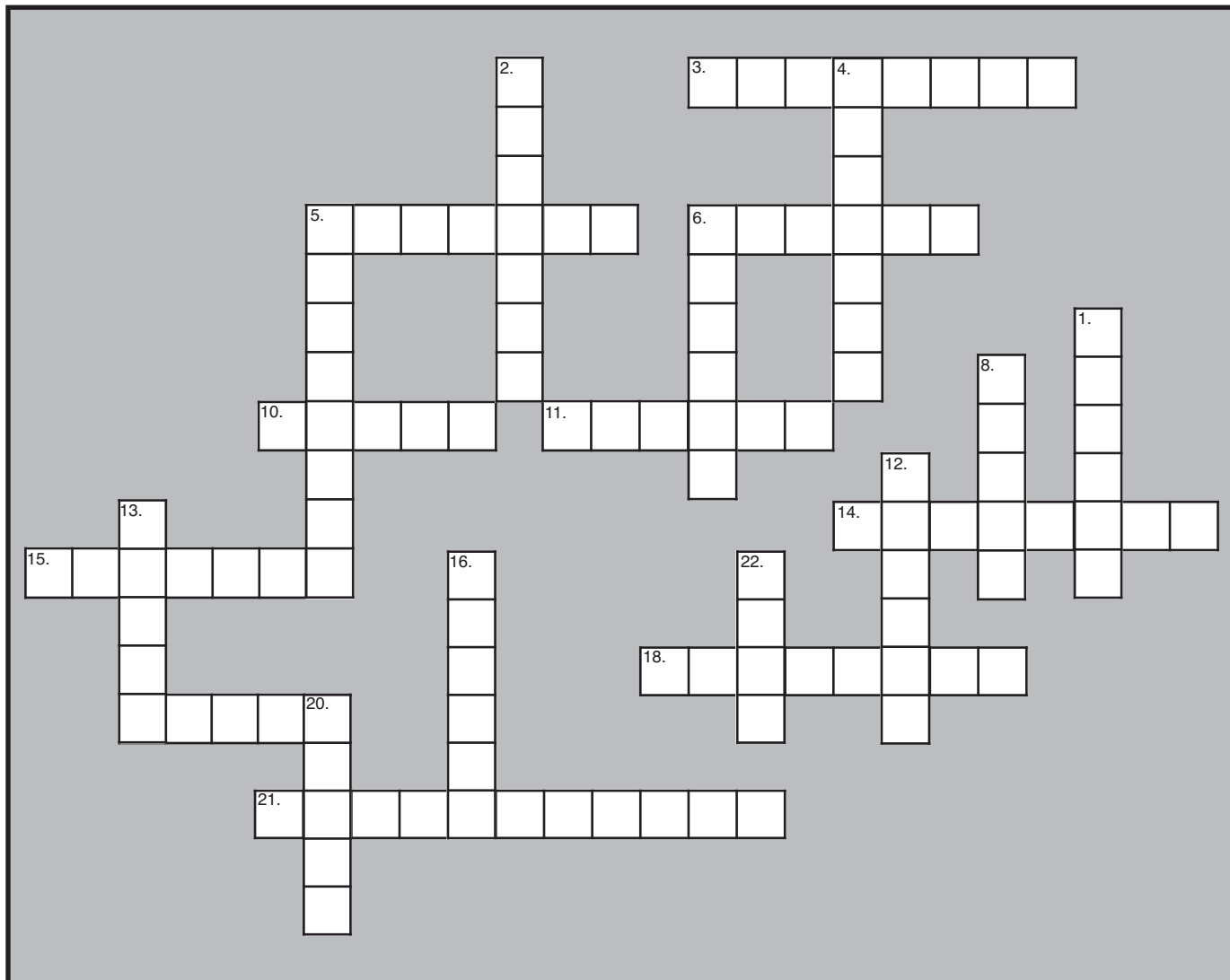

CLEAN UP

Litter, litter, it's all around me. Litter, litter so ugly to see. Cans and bottles, papers and cups, thrown out windows of cars and trucks. Litterbug, litterbug, why can't you see? Put litter in a bag. You know that's right. Let's all work together to keep Pennsylvania a beautiful sight. Clean it up!

D

DETOUR

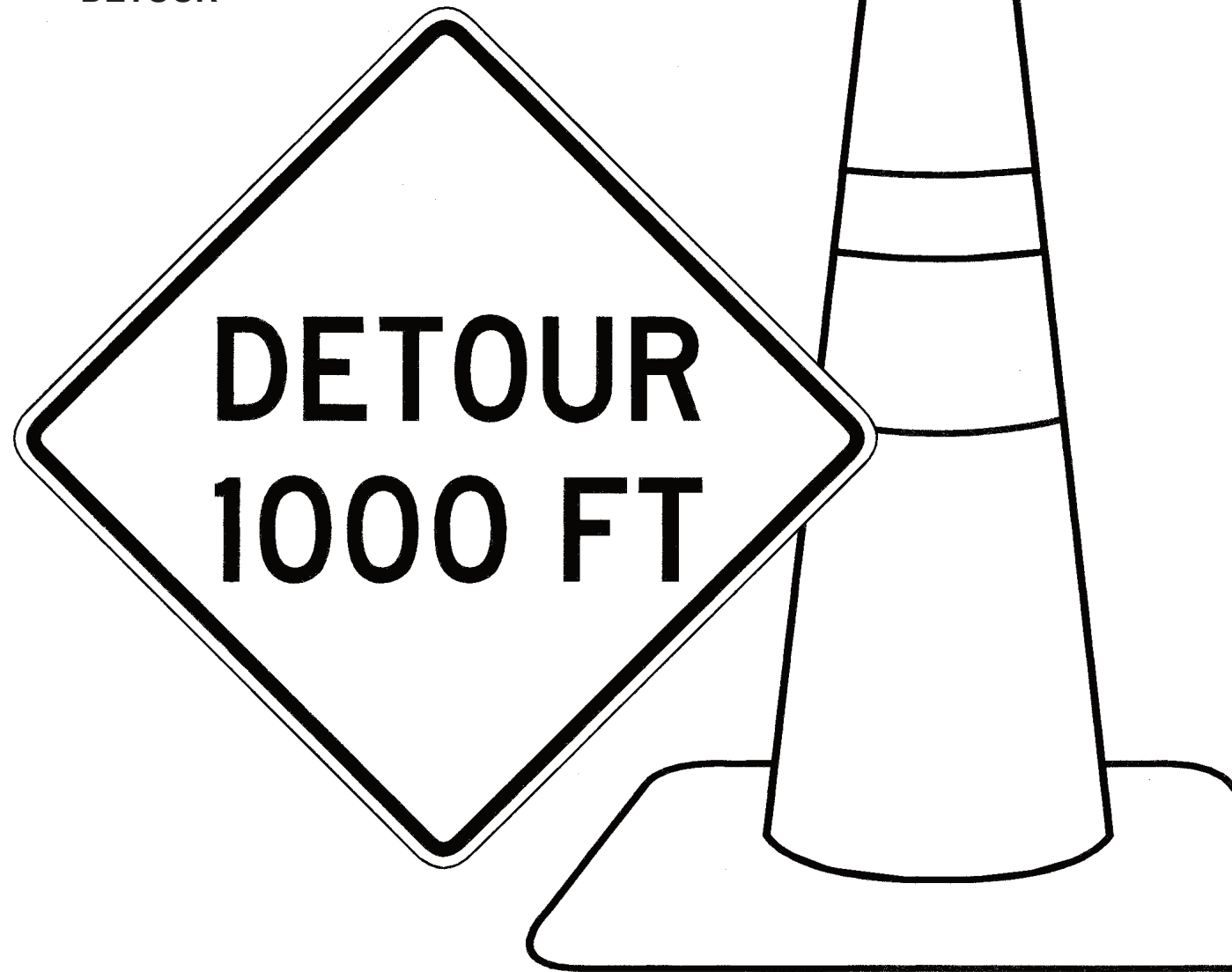

What is a detour? Just like everything else, bridges and highways wear out. When repairs are needed, highway workers sometimes close a road to all vehicles. First they put up signs with large arrows that show motorists how to get around the road work and on their way. The route of travel you take to get around a closed road is called a detour.

W

WORKING

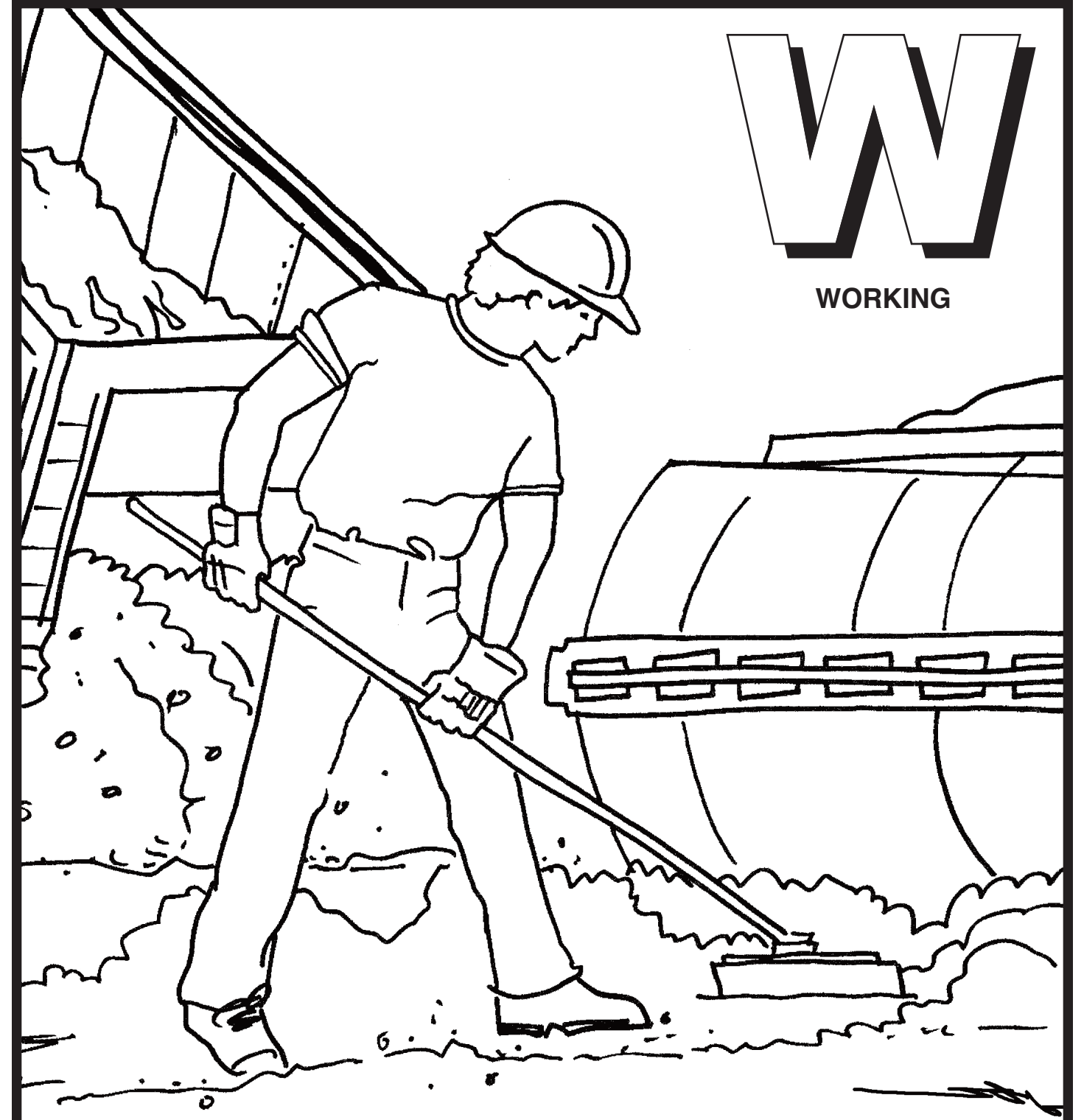

Working outside can be quite a bummer. It's 100 degrees in the middle of summer. In the winter it's cold and the wind really blows; you're frozen from your head right down to your toes. We get poison ivy that makes us all itch; there are bees, mosquitoes and nasty ticks. With bugs and weather it seems hard to win, but I'd rather be out than have to be in.



VESTS

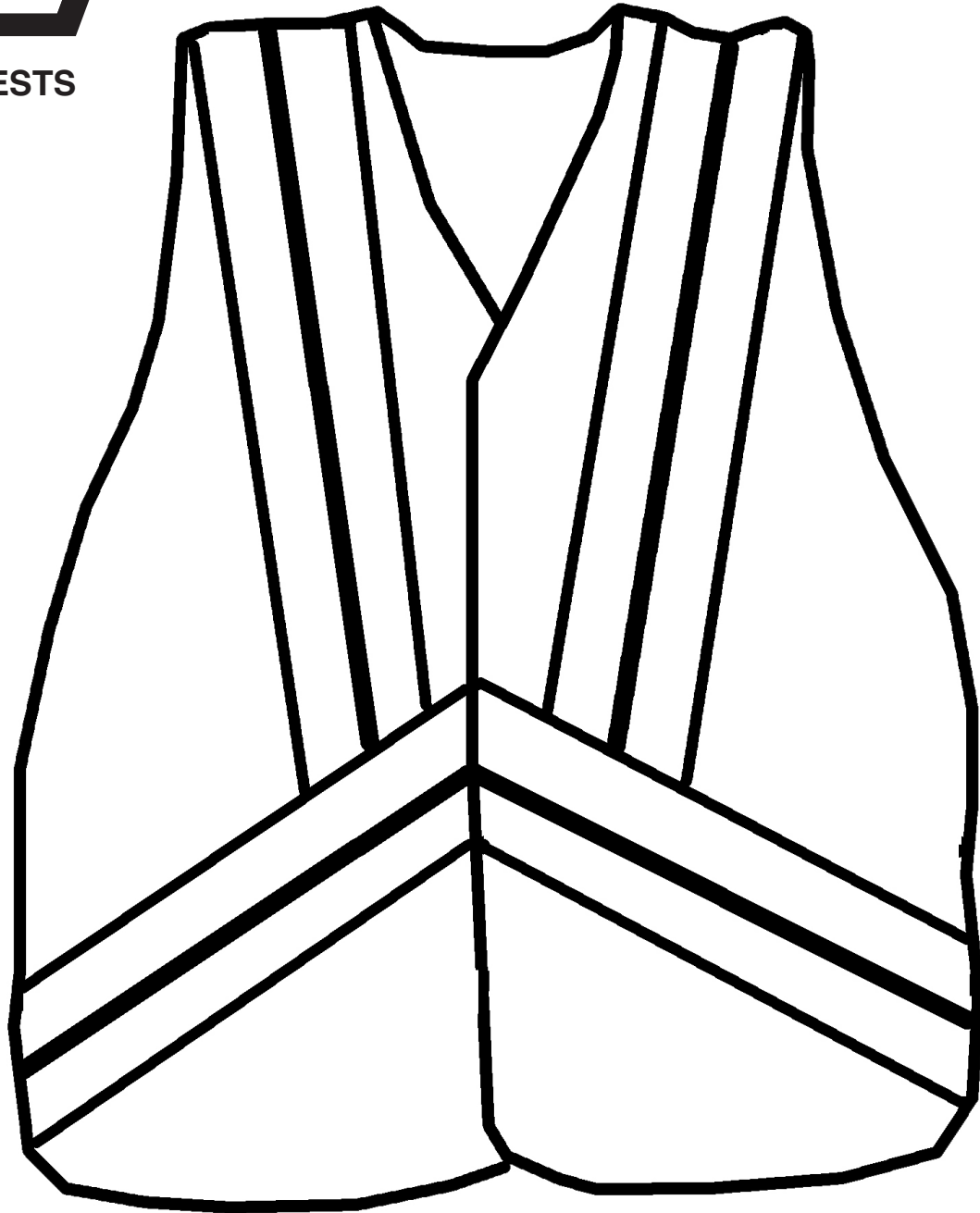

Safety Vests are important to our crew in the field. They protect these people just like a shield. They're brightly colored fluorescent orange or yellow-green. They alert motorists to a working fellow.



EQUIPMENT

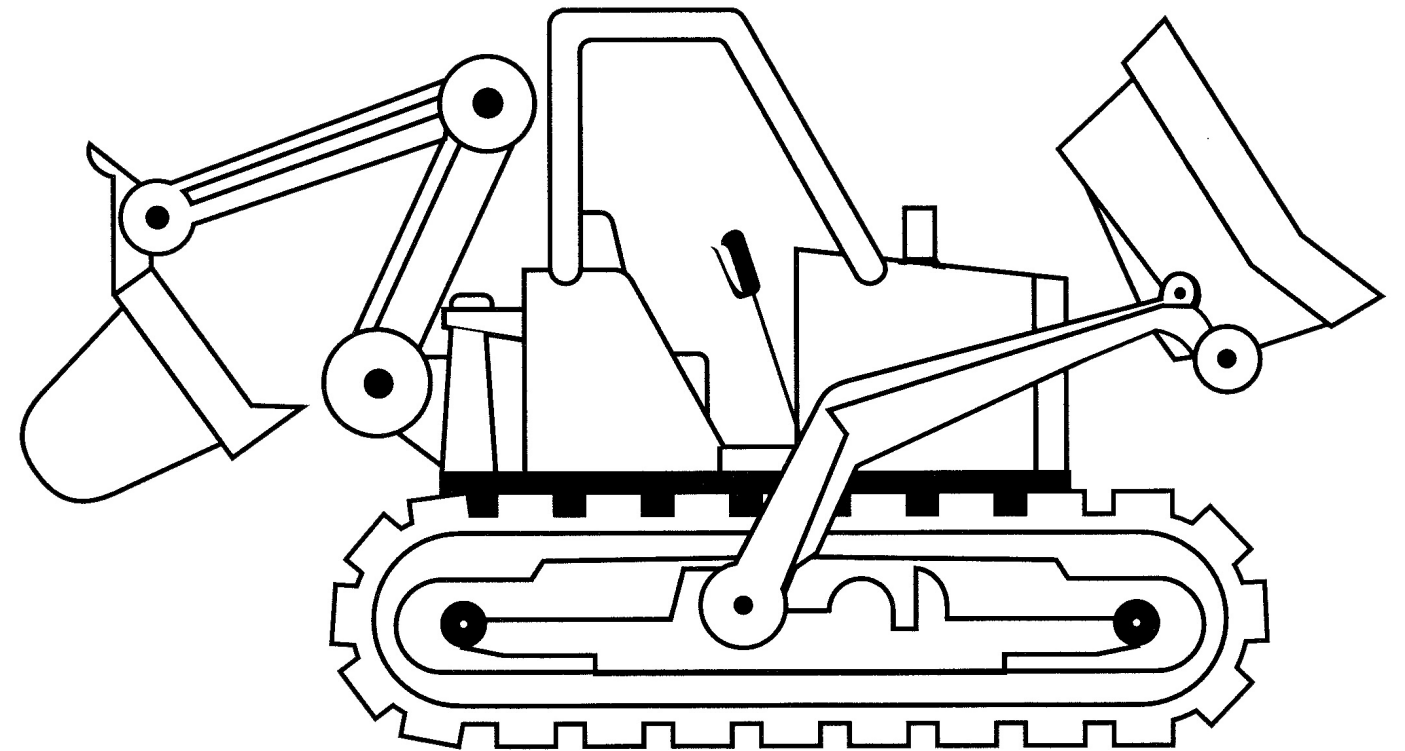

PennDOT uses a lot of equipment to build and repair roads and highways. These include gradalls, beltloaders, graders, backhoes and dump trucks.

F

FLAGGER

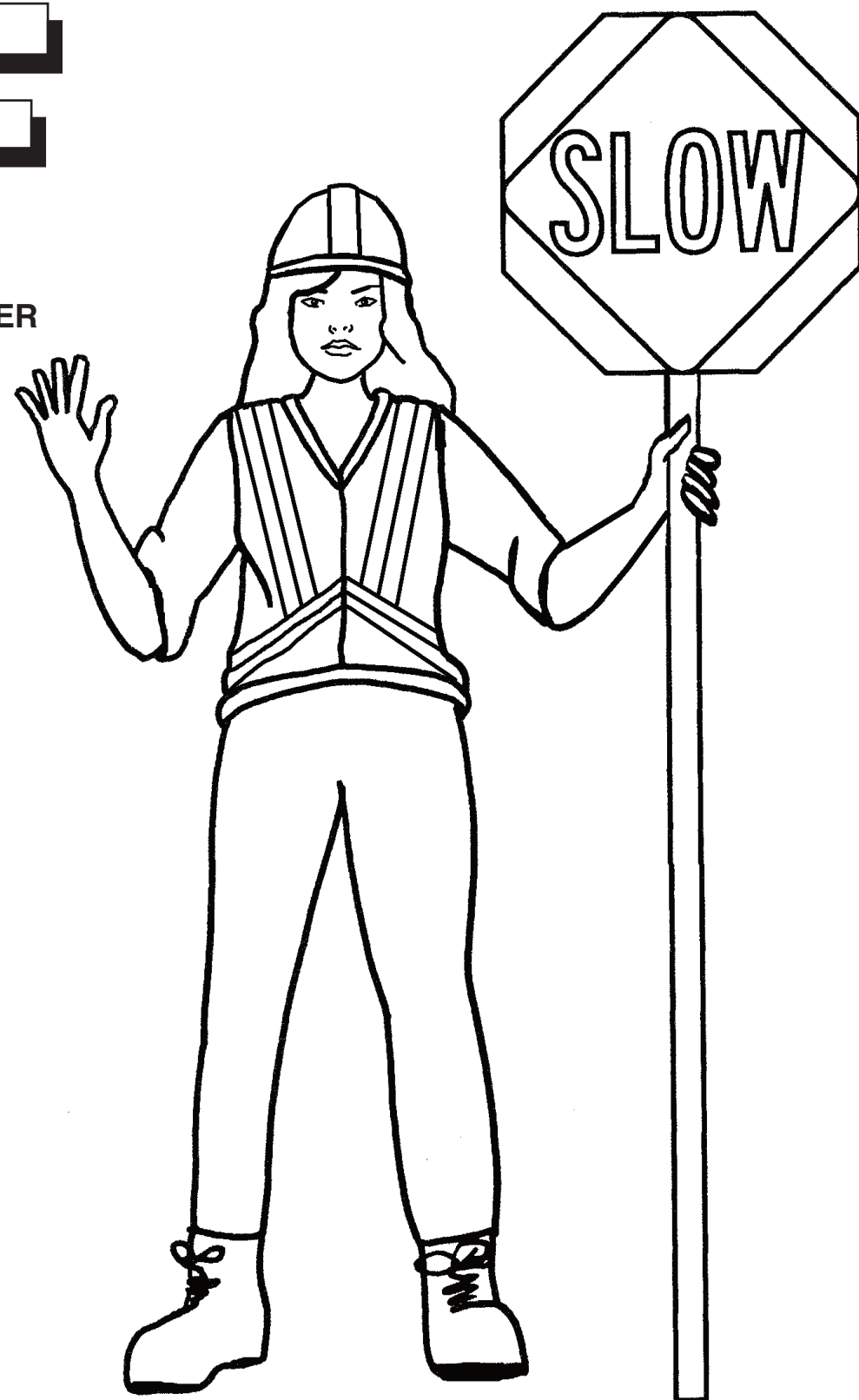

Flaggers are a very important part of the job. Safety is their game. They protect members of the crew. Keep them out of harm's way. The flagger's paddle tells you what to do. Stop or proceed. Please respect the flagger's job. It's for your own safety, you see.

U

UNICYCLES

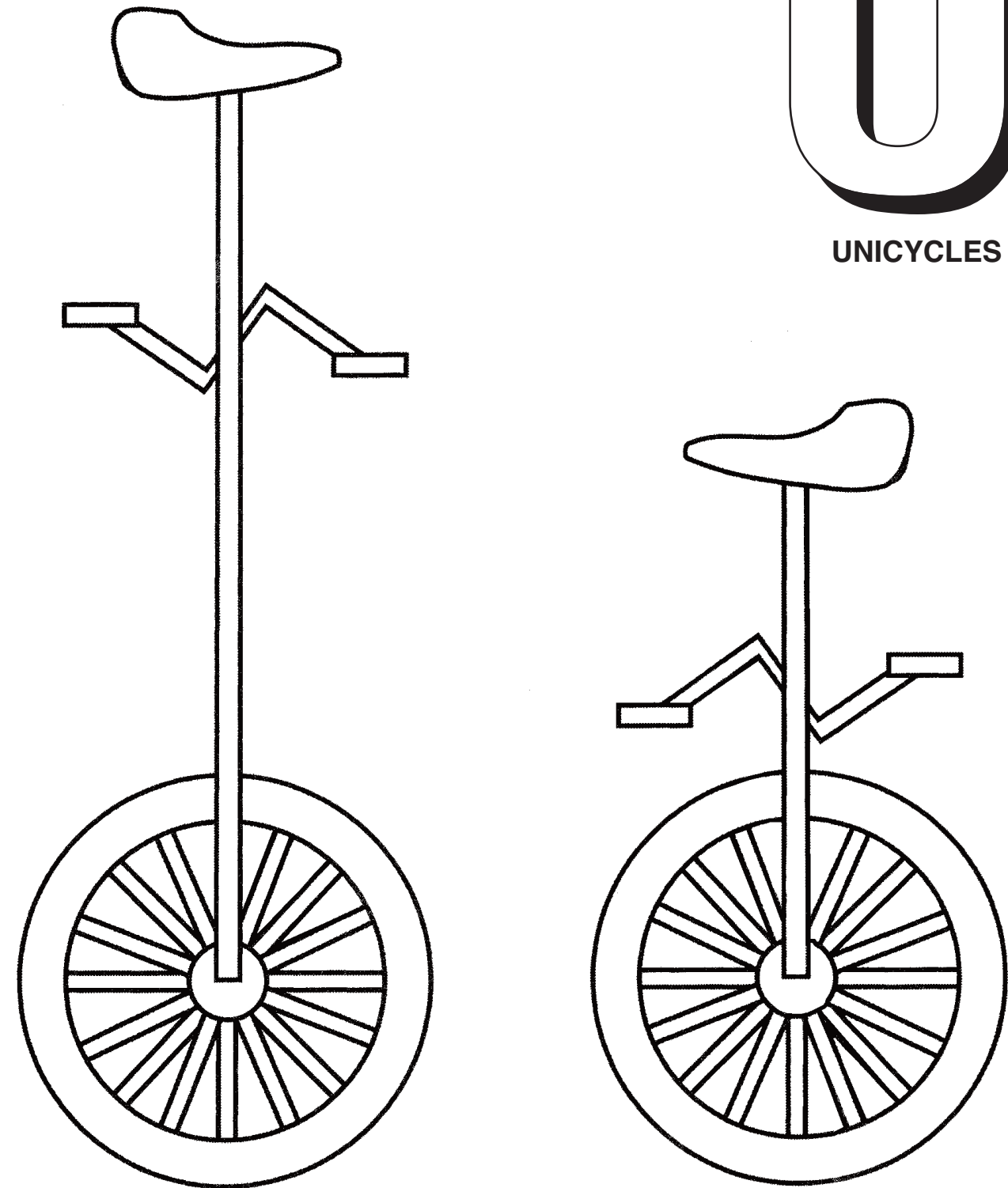

Today we see unicycles most often at the circus or being ridden in a parade. But just as they would a car, some people use unicycles as a form of transportation. The first unicycle was made in 1869. Today they have been largely replaced by the bicycle.

T

TRAINS

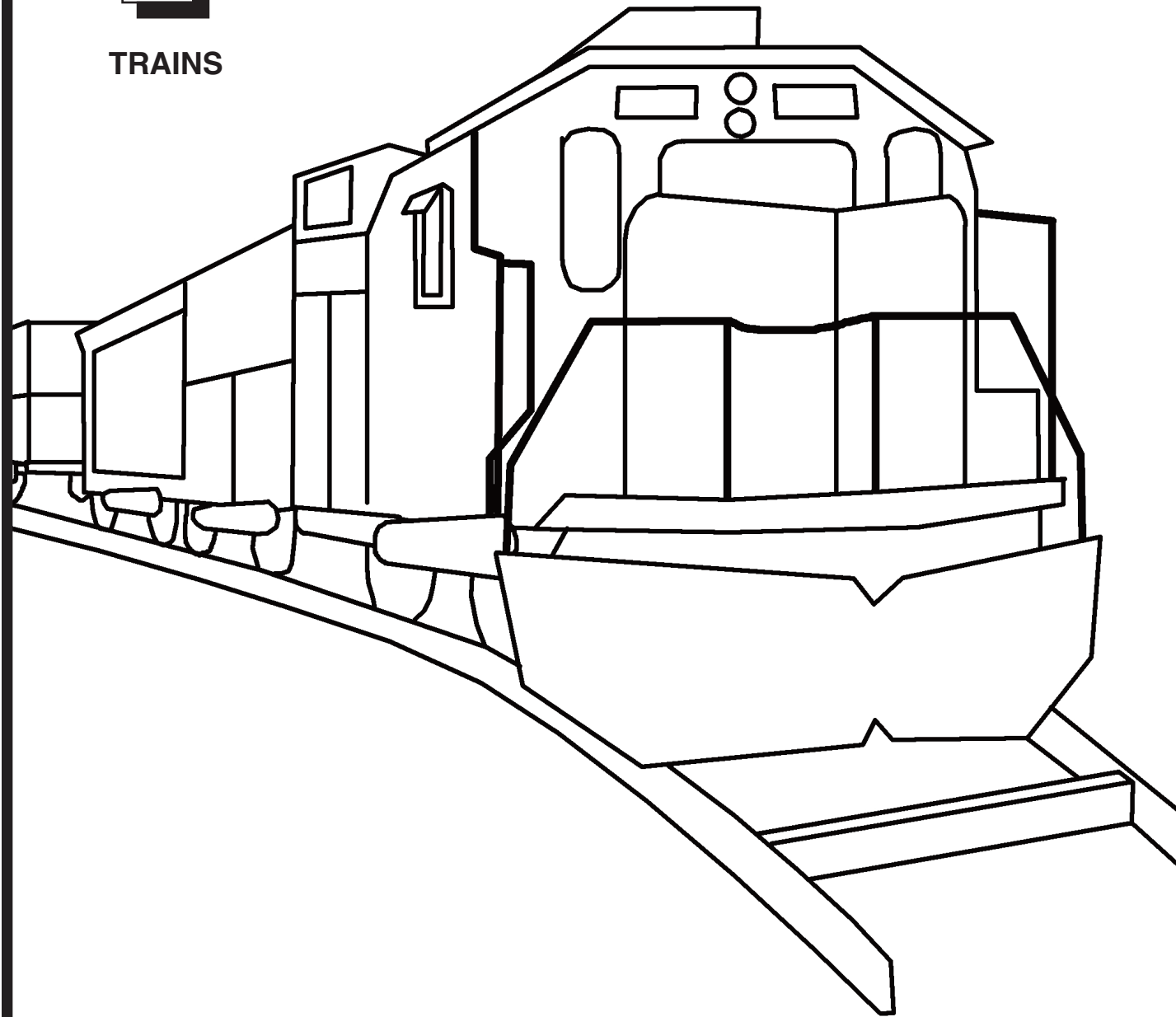

Trains play an important part in our transportation system. They carry people from one city to another. Trains also carry freight, such as coal, chemicals and cars. As more and more cars and trucks take to the highways, it is good that we can still rely on trains for transportation.

G

GRADER

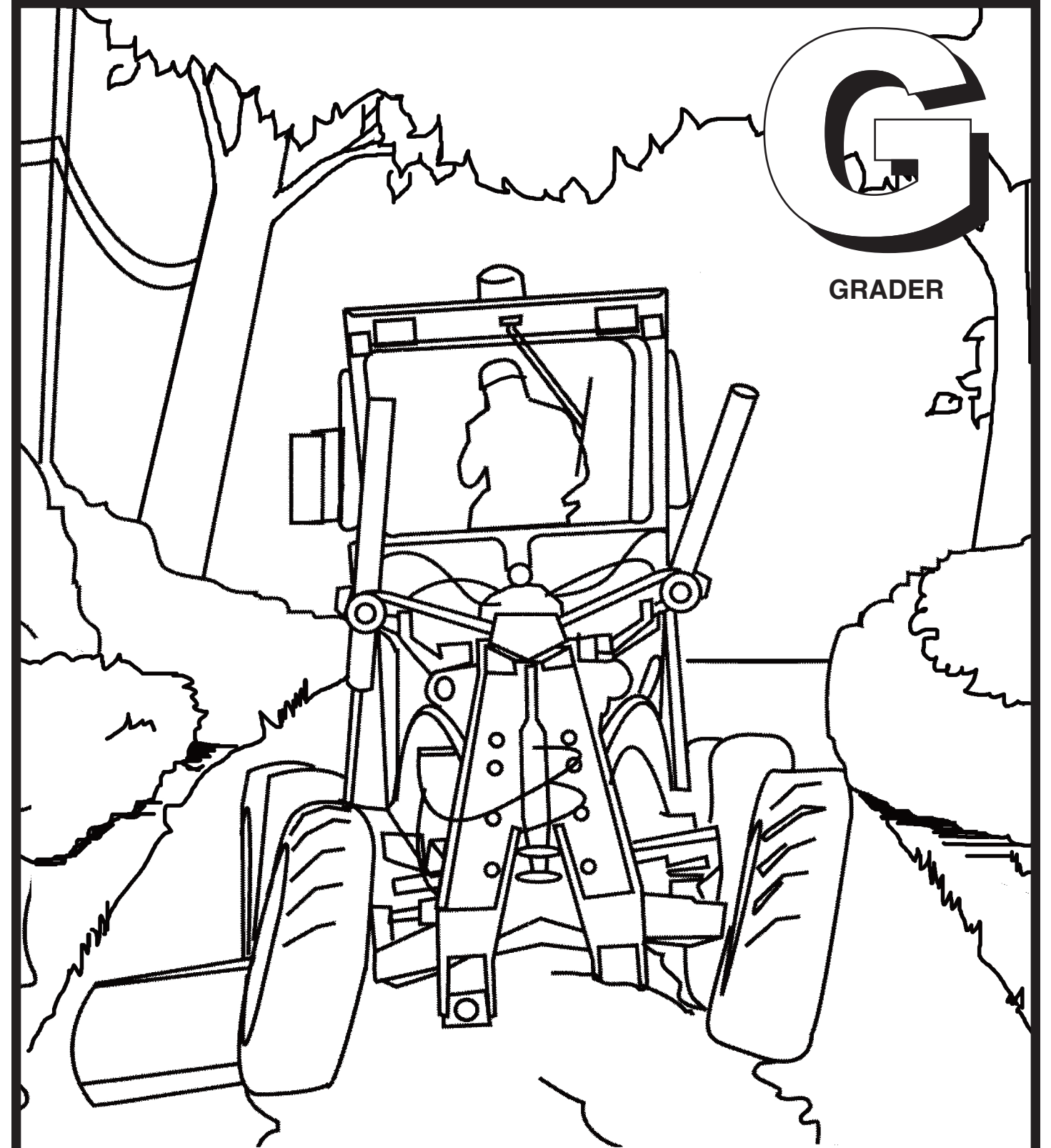

Hi, I'm Cindy, an equipment operator. One of the pieces of equipment I operate is a grader, just like the one pictured. In the summer we use the grader to cut or grade the shoulder of the road. In winter, we use it to plow snow and cut ice build-up on roads.

H

HARD HAT



We don't like our hard hats and yes we complain. But deep down we know, they're protecting our brain. Accidents can happen. If you get hit on the head, instead of your noggin, it'll hurt the hard hat instead.

S

SEAT BELT

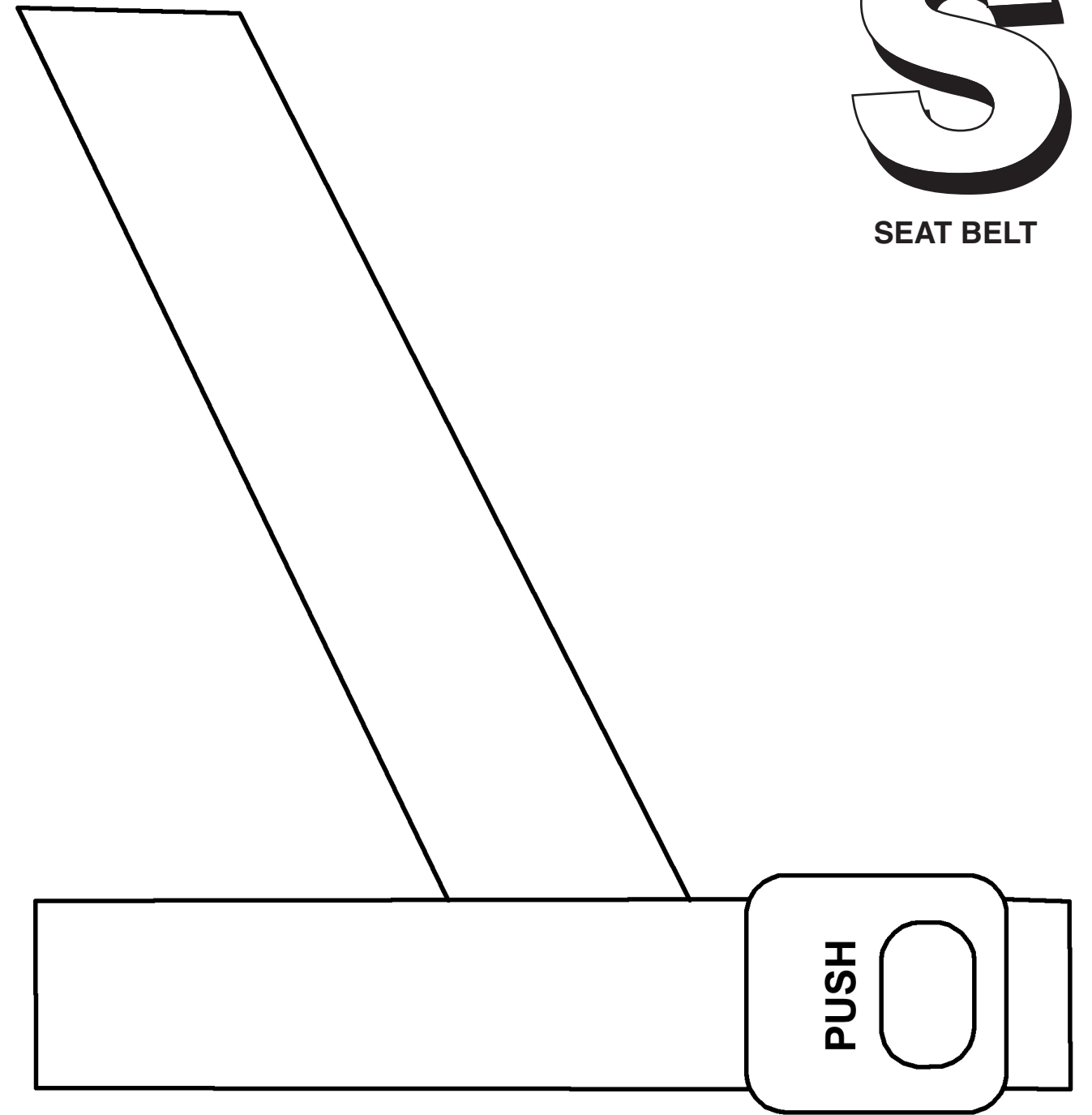

Every time you get in a car or other vehicle, wear a seat belt. It's the law! Make sure that Mom and Dad, brothers and sisters, and anyone else who rides with you buckles up. Wearing a seat belt can prevent you from being hurt in a crash.

R

ROADS

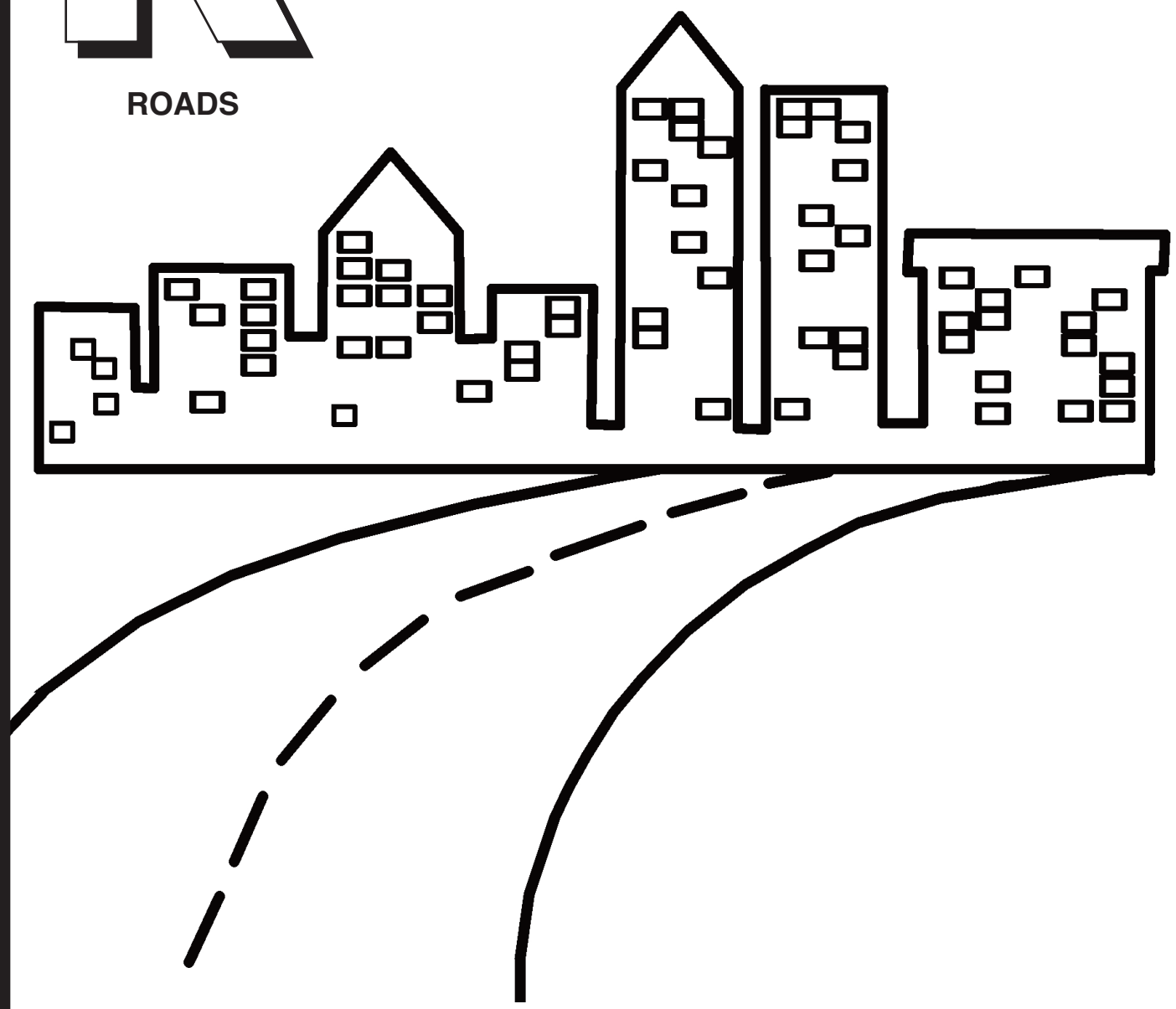

Roads, roads, where do they go? Back and forth, to and fro. Up and down and round and round, in and out of every town. Some are straight, and some are curved. Some really will test your nerve. Roads, roads, too many to count, down in the valley, and up on the mount. They'll take you here, and take you there, but boy they need a lot of care. They get holes, and ruts and bumps from all the wear, they take their lumps.

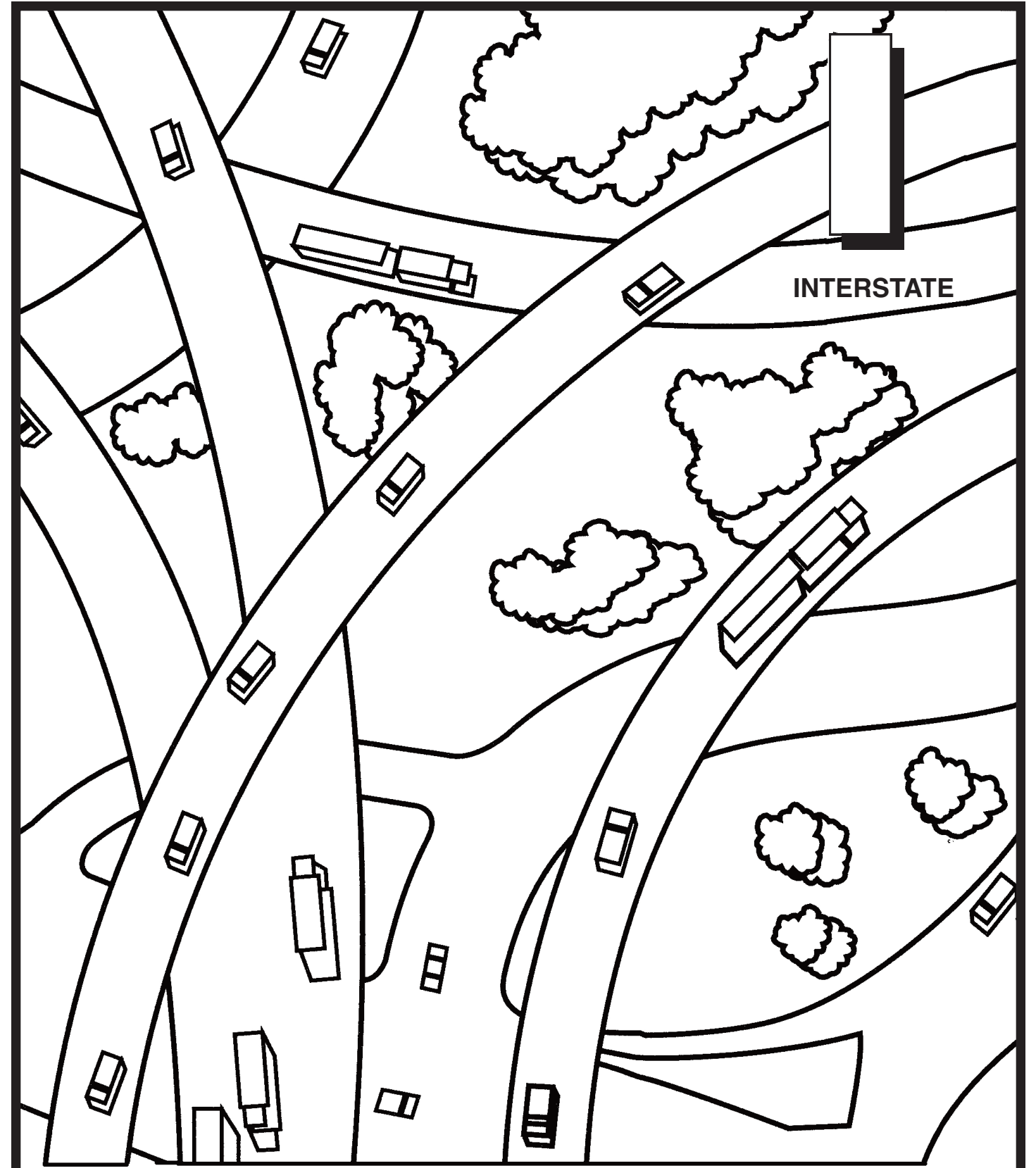

Interstate highways are really neat. They're usually four lanes, six lanes, even eight lanes or more! They run from one state to another -- north to south and east to west -- and often from one end of the country to the other.

J

JAYWALKING

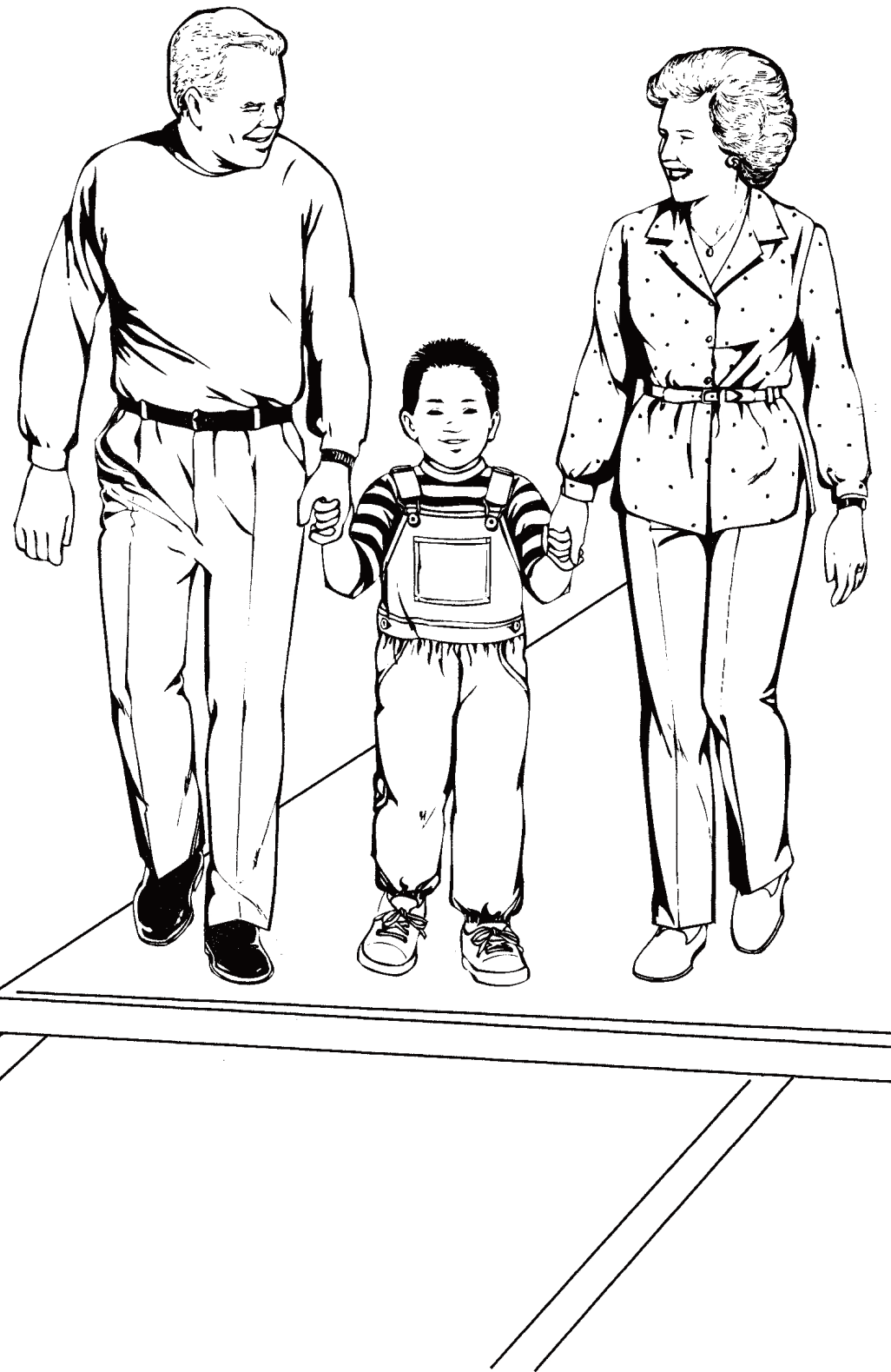

Jaywalking is unsafe. Crossing the street in the middle of the block is called jaywalking. Always cross the street at the corner or where a crosswalk has been applied to the road's surface. Never jaywalk!

Q

QUARRY

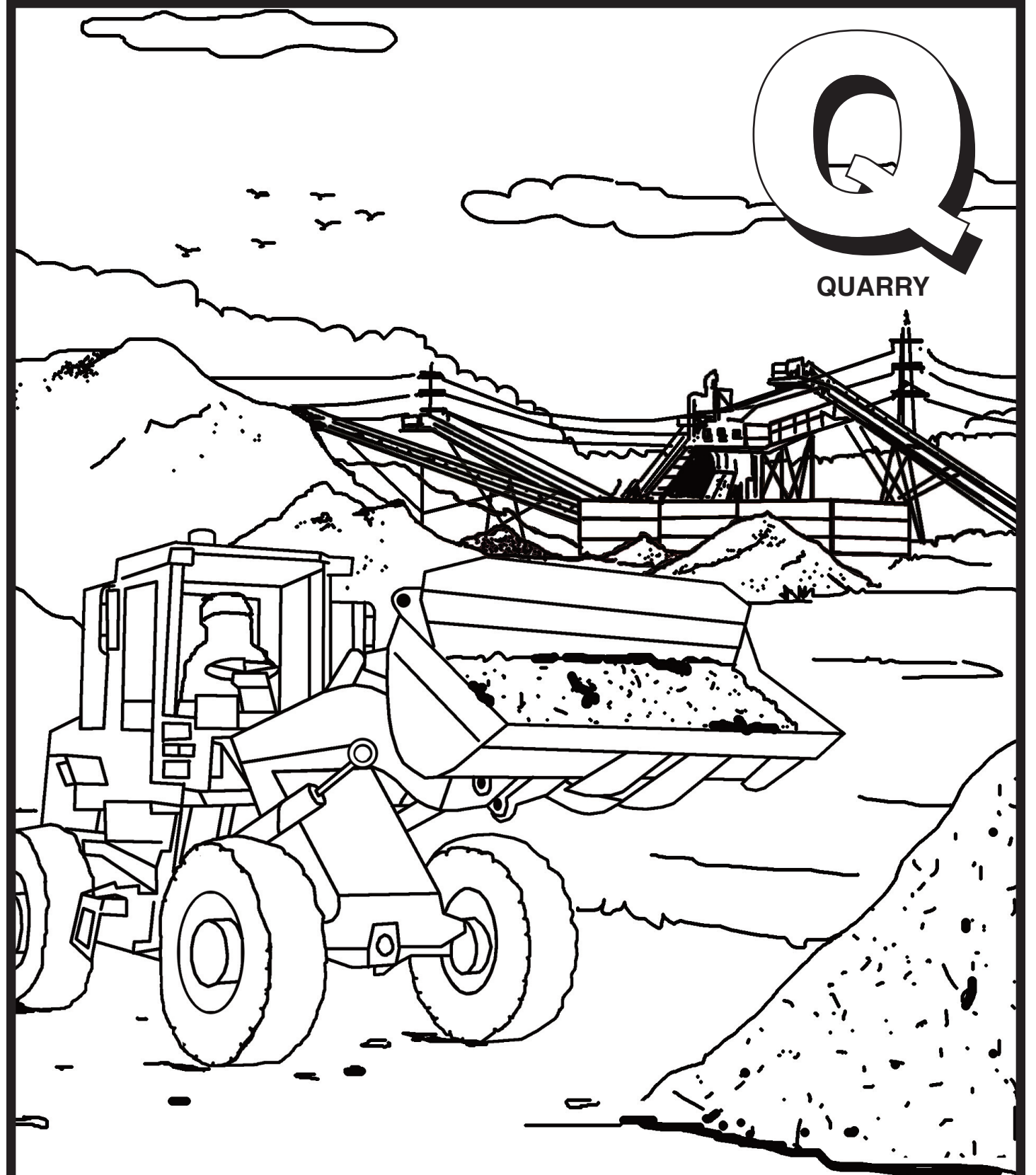

Highways are made with bituminous asphalt or concrete. The particles that make up bituminous asphalt and concrete come from deep in the earth. The location where large machinery is used to dig up these minerals is called a quarry.

P

PLOWS

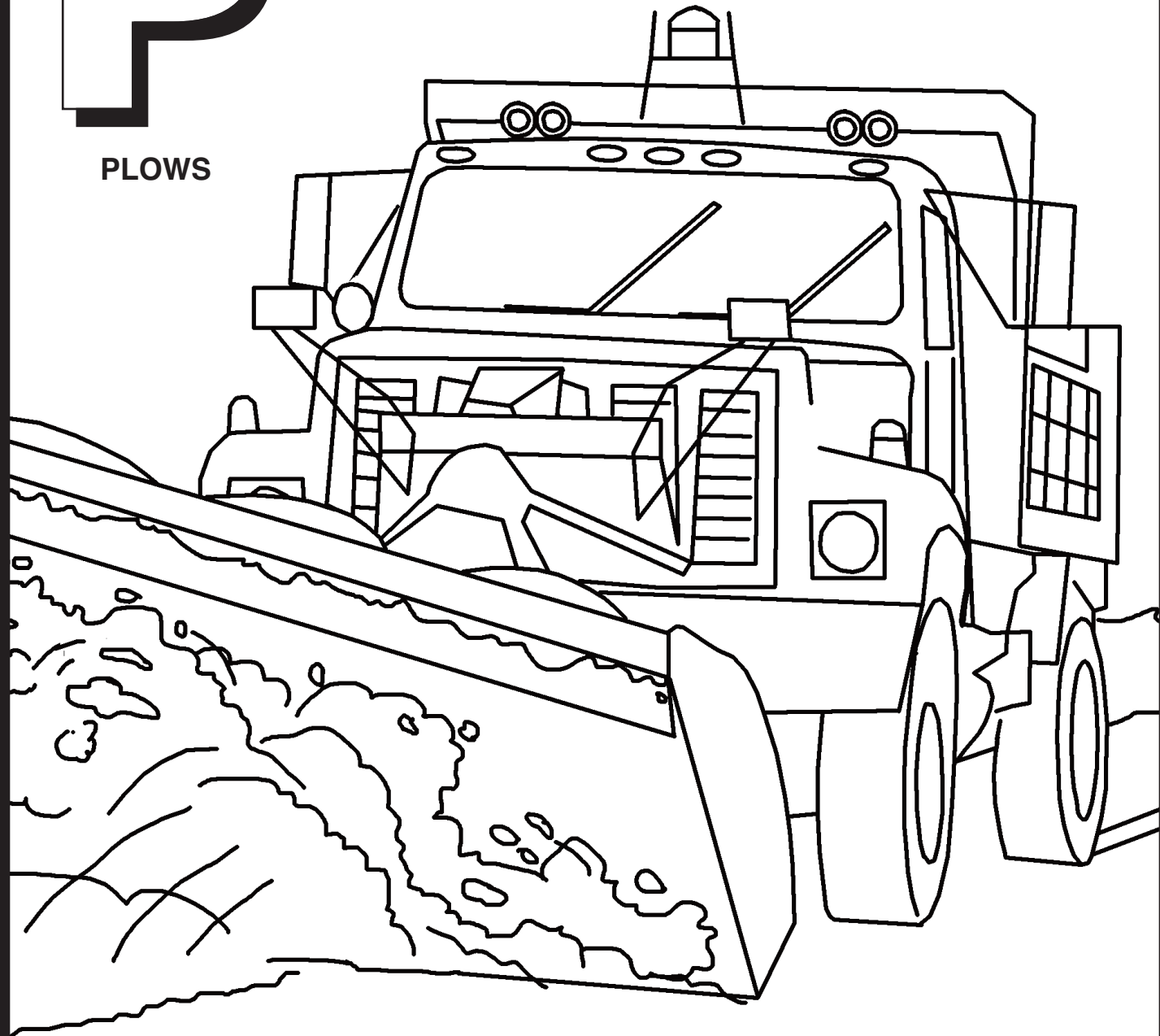

In the wee hours when the phone rings, I hit the floor and gather my things. A winter storm is upon us in full swing. I jump in my pickup, to my stockpile I go, whether it be icy, sleeting, freezing rain or snow. I check out my dump truck, make sure everything is right. I clean off my windshield, my head and tail lights. I load up my truck with salt and away I go. I head for my route to plow some snow.

K

KEEP
PENNSYLVANIA
BEAUTIFUL

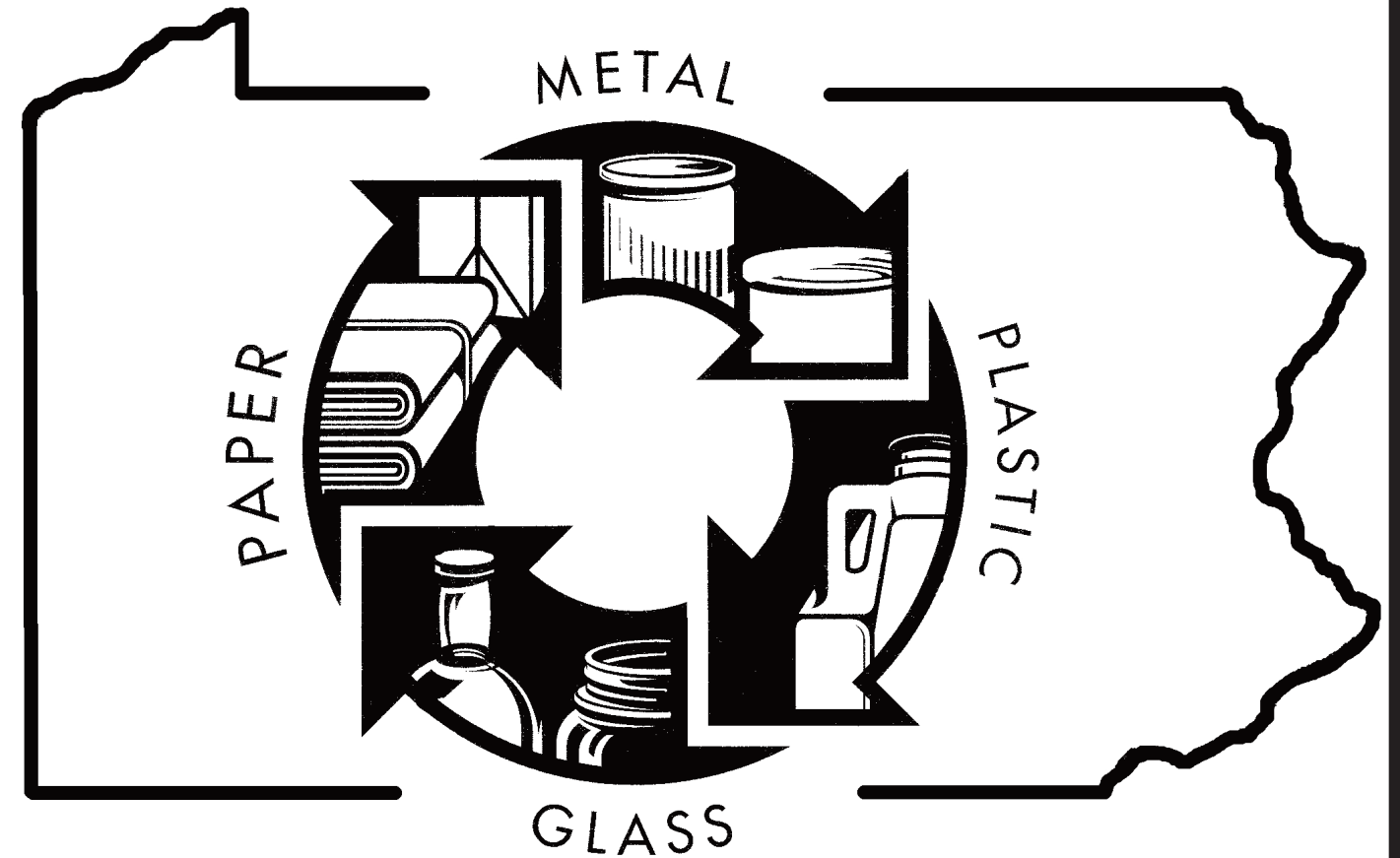

Every spring, thousands of volunteers pick up litter along the highways of Pennsylvania on Keep Pennsylvania Beautiful Day. You can do your part by putting litter in its place. Carry a litter bag in the car, put trash in it, not out the window. Ask others to do the same.

L

LOADERS

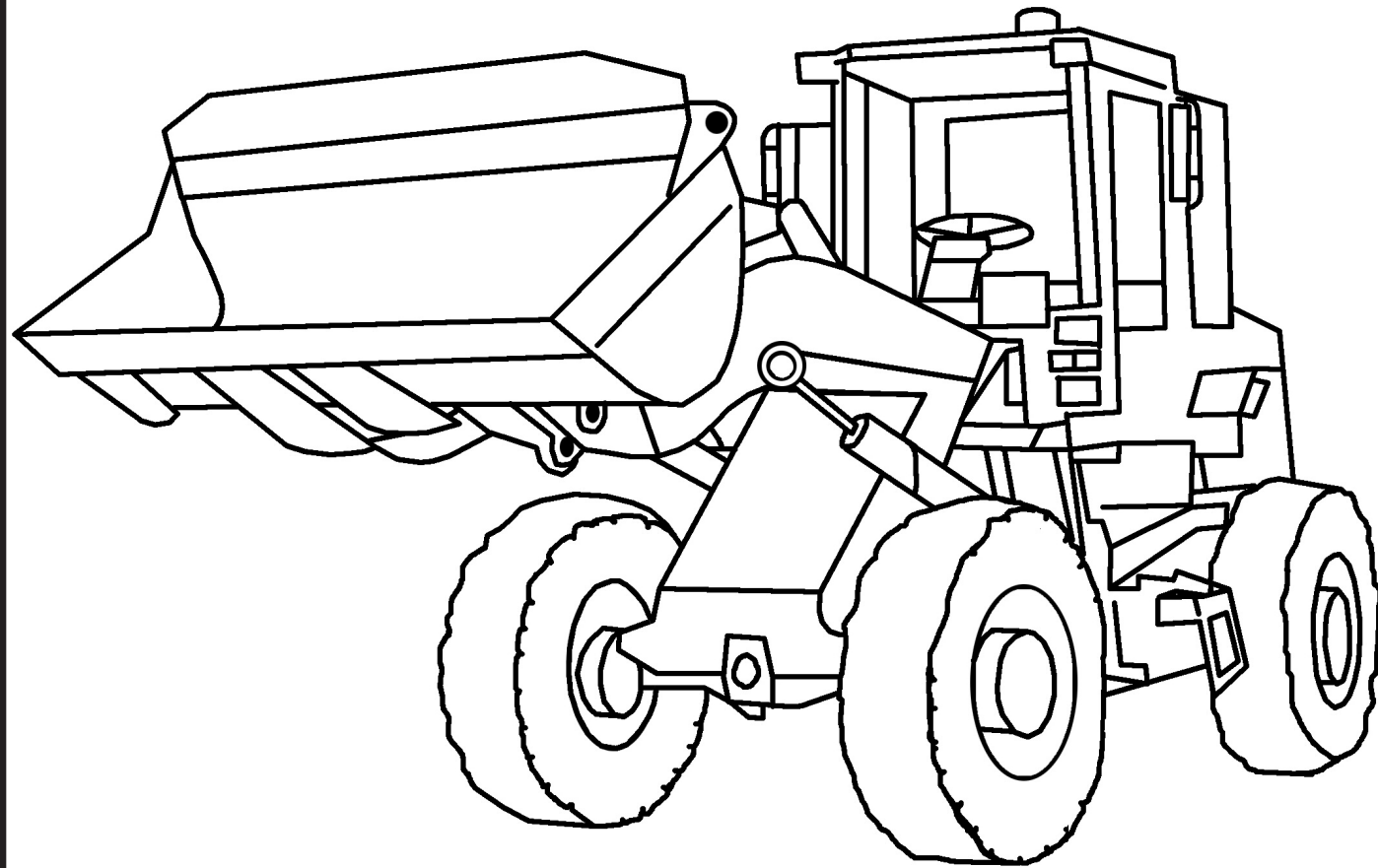

Loaders have buckets that pick up and dump. They can dig a big hole or level the bump. The loaders are handy and save lots of work. All that heavy lifting can make a body hurt. With great big engines and all kinds of power, they can move mountains or help build a tower.

O

OPERATORS

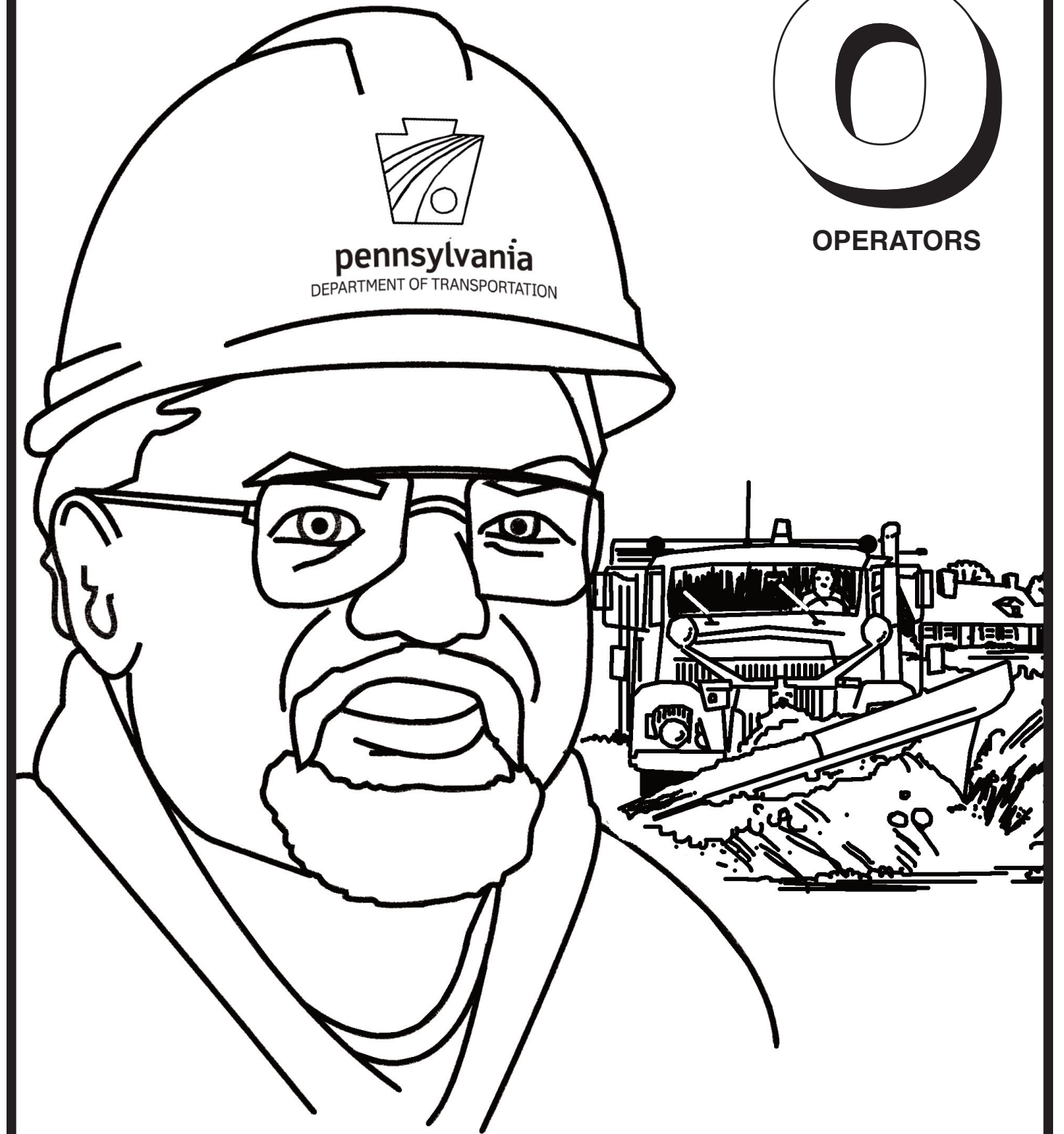

I am an operator; I work upon the road. In spring I fix potholes; in winter I plow snow. I work in all kinds of weather, from freezing winter wind to warm summer rain. And when I am finished I start all over again.

N

NUMBERS

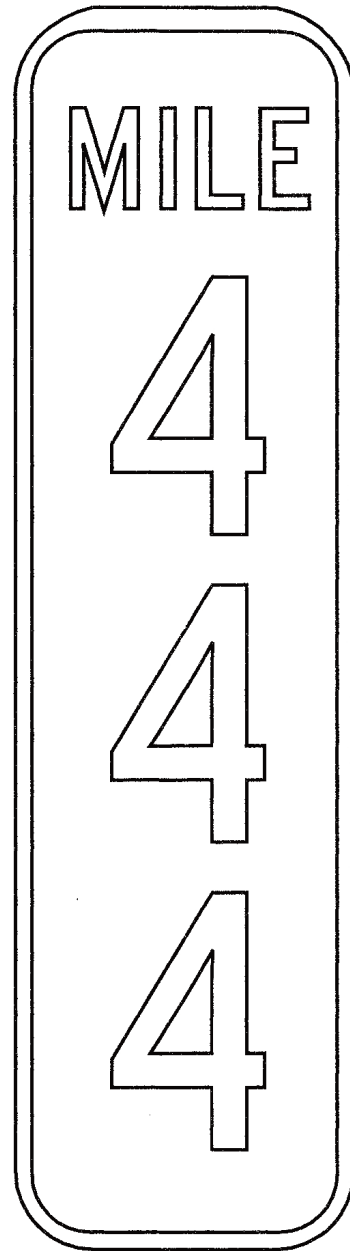
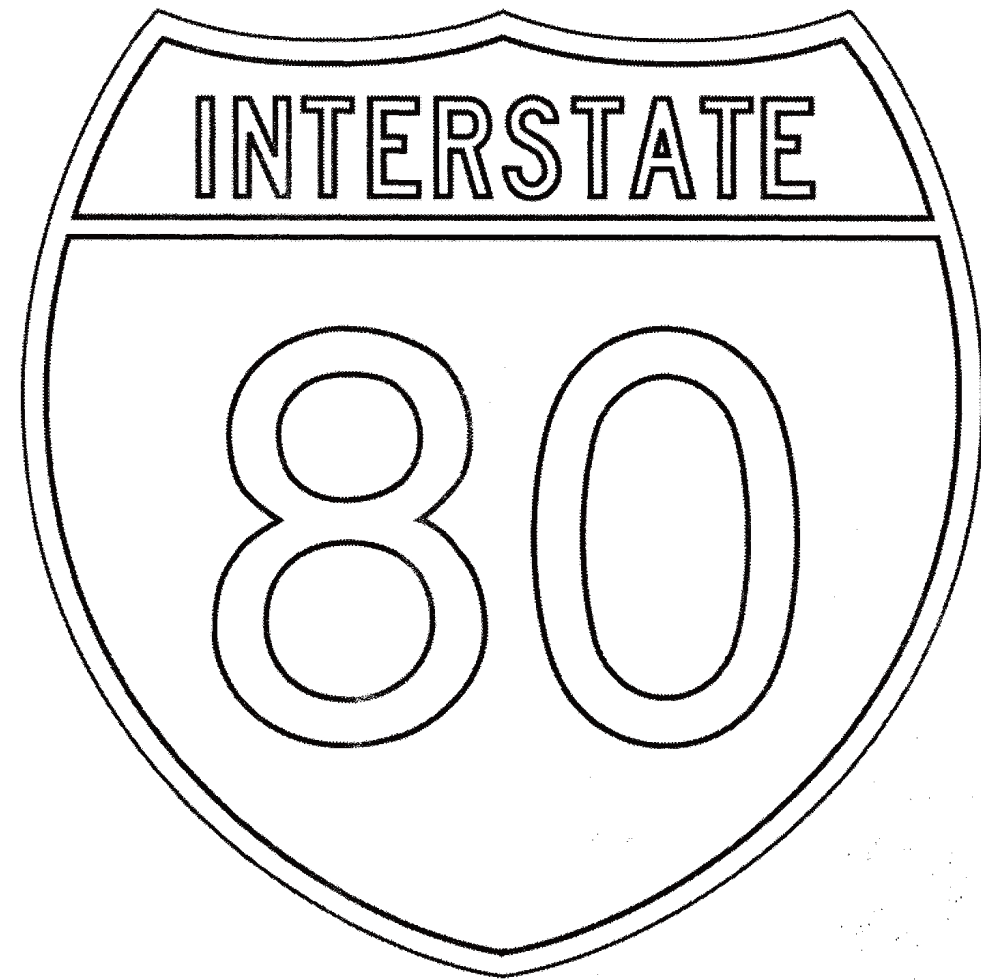

All of our state and interstate highways are listed by number. Many local roads where you live have names, like Main Street or Boulevard of the Allies.

M

MECHANICS

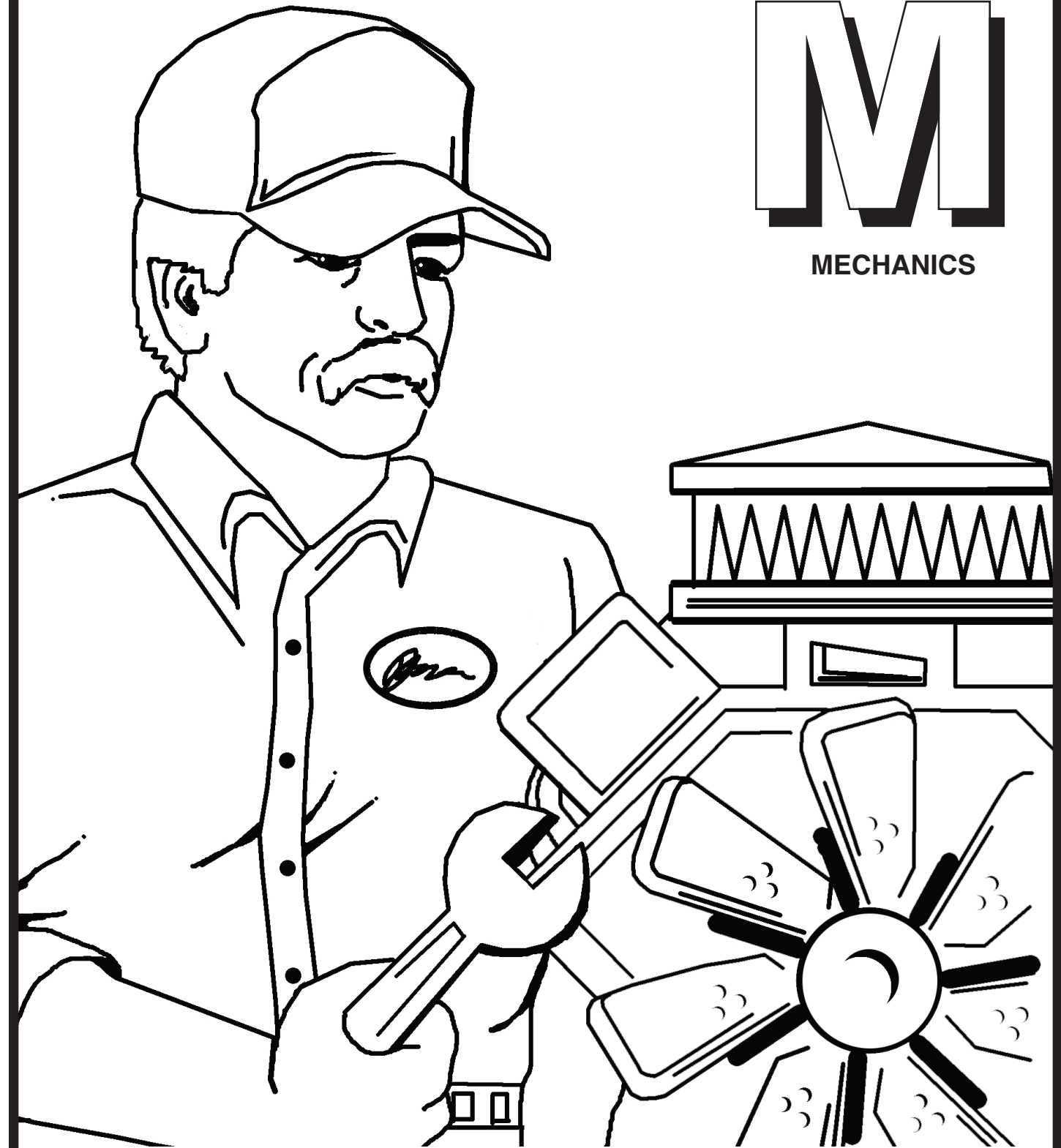

Trucks and loaders, backhoes and cranes, dozers and trailers, graders and trains. One thing about them, I think you should know, sometimes they break, when you want them to go. Tires go flat, engines won't start. We need mechanics, who are very smart. They're like doctors, who fix up machines. When we're broken down, they're on the scene.

START
HERE

This is a construction site maze. Please help
the car follow the signs that PennDOT has put up
in order to go around the job site.

What is it called when you take a different route of travel
to get around a construction site? _____

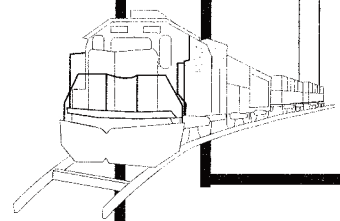
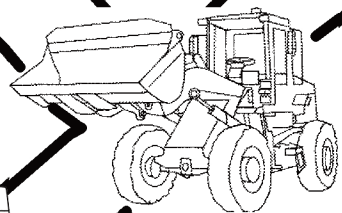
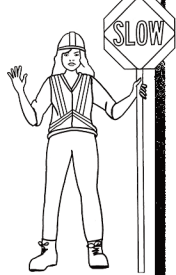
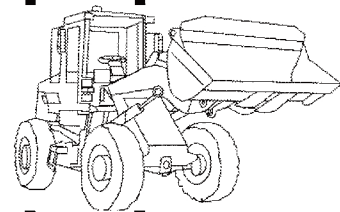
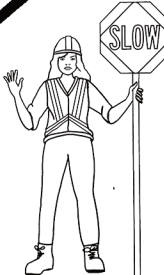
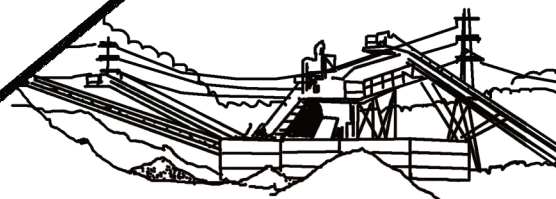
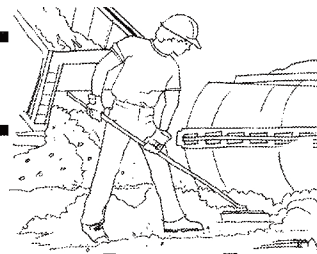
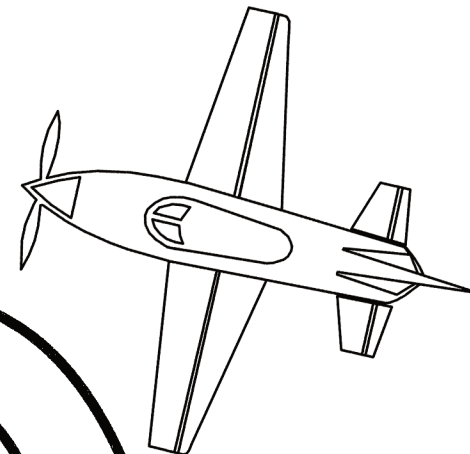
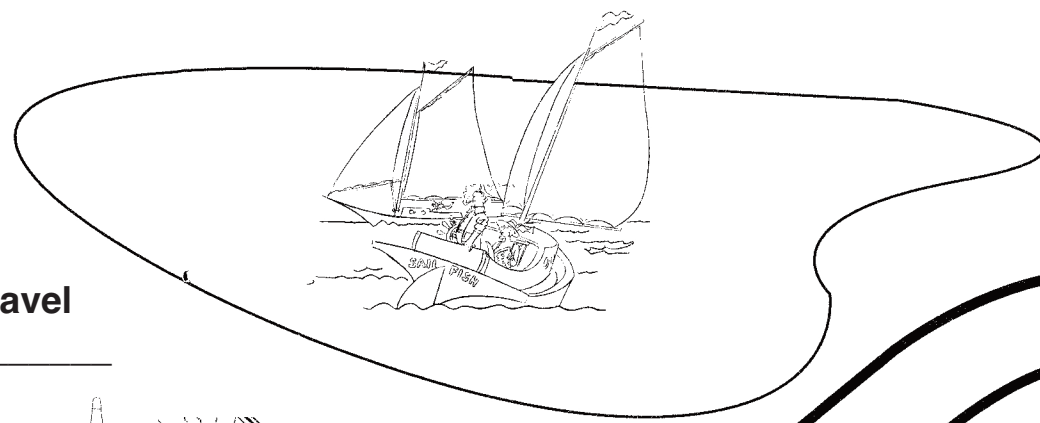

END HERE

